



LoRaWAN® Product catalogue



Contents

01-02

About Our
Company

03-04

Smart
Buildings

05-06

LoRaWAN®
Benefits

07-08

Our
Solutions

 Indoor Climate

09-11

Vicki
LoRaWAN®

12-14

HT
LoRaWAN®

15-17

Wireless Thermostat
LoRaWAN®

18-20

Fan Coil Thermostat
LoRaWAN®

 Air Quality

21-23

CO2 Sensor
LoRaWAN®

24-26

CO2 Display
LoRaWAN®

27-29

CO2 Display Lite
LoRaWAN®

 Water control

30-32

T-Valve
LoRaWAN®

33-35

Flood Sensor
LoRaWAN®

 Automatic devices

36-38

Multipurpose Button
LoRaWAN®

39-41

Open/Close Sensor
LoRaWAN®

42-44

16A Switch & Power
Meter LoRaWAN®

45-49

MClimate
Enterprise

50-52

Utilities

About us

Introduction

MClimate is an IoT company which designs and develops affordable and universally compatible smart home and smart building automation solutions with a focus on delivering enhanced comfort, security and energy savings to its end users.

The Company is founded in 2015 and is headquartered in Sofia, Bulgaria with a local production and assembly facility in Veliko Tarnovo.

MClimate has a proven track record in designing state of art hardware sensors and actuators using WiFi and LoRaWAN. We are gateway and IoT platform agnostic and our mission is to make the world a more connected and smarter place.

We also offer software white label solutions: proprietary end user application and desktop analytical tool for instant 24/7 monitoring and control.

Production facility

MClimate uses one of the most experienced and internationally accredited and certified Contract Electronic Manufacturer.

It has secured dedicated production lines and experienced staff for MClimate production since 2015.

The state of art production facility includes 3200 sqm. production of electronic modules site, 2300 sqm. production site and 900 sqm. R&D engineering and administration site. The production capacity for MClimate and its portfolio includes 8 production lines with ability to produce and test up to 160,000 devices per month.



2

EU based production facility

60+

International markets covered

20+

Designed hardware IoT devices for smart automation

400k+

Devices delivered

2500+

Smart buildings served

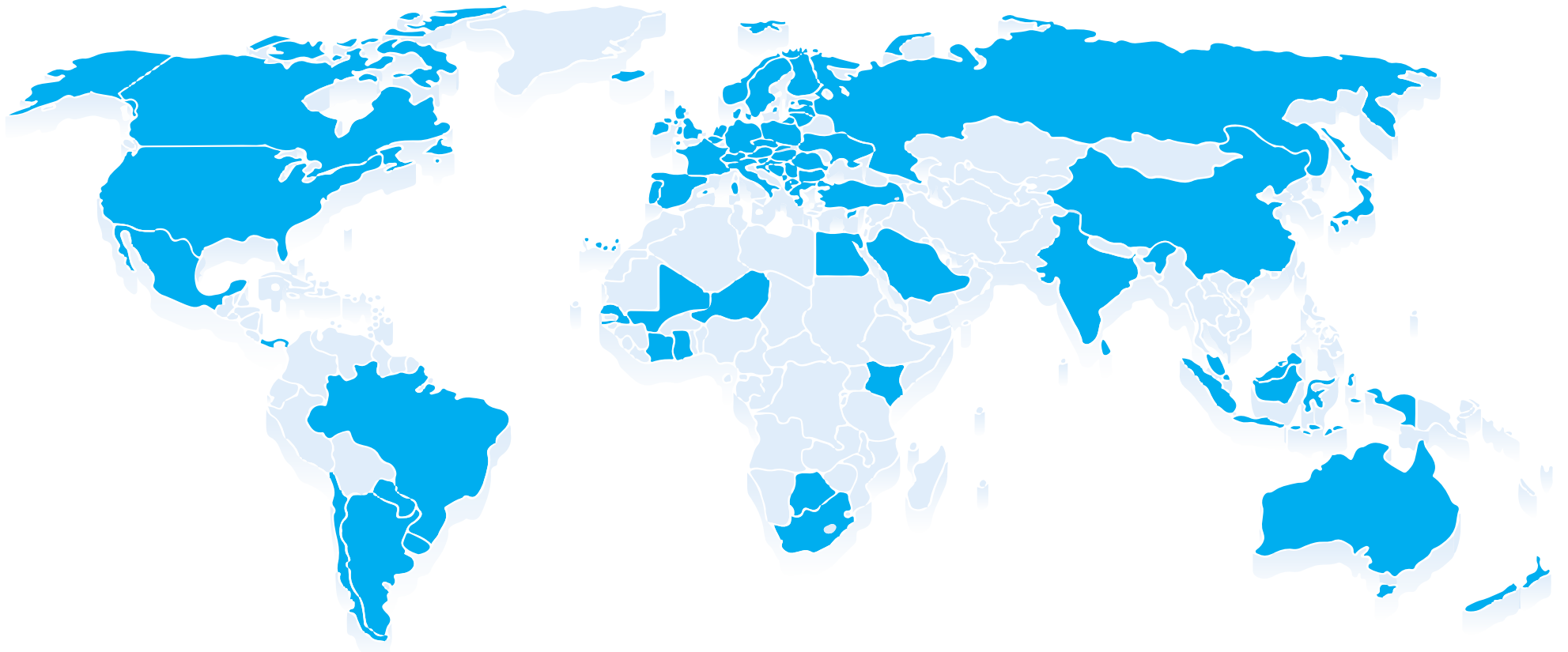

2015, 2016

Selected by the InvestBulgaria Agency

2017

Becomes an Endeavor company

2020

Selected in the Top10 BG Fastest Growing Scale Ups

2021

Participation in EU accelerators for smart city and smart region solutions

2022

PwC and Growth Builders PropTech Solutions

2022

Funding round to fund further growth in Europe and launch of Enterprise v2 with EBRD

2023

Introducing new maintenance-free solar-powered smart devices series

Smart Buildings

Our mission to provide digital, connected, smart and low carbon footprint buildings automation products and services to our customers is fully aligned with major corporates and government objectives to prepare their assets and clients for the future through innovation.

⚡ 30%

Save and monitor energy, time and money and do your part for the environment



Quick time to market with low upfront investment and high ROI



Work towards carbon neutrality goals and 2030 targets in line with the UN's SDGs



Use AI and data to drive business insights and optimise risk and business strategies



Increase existing revenues and utilise resources more efficiently



Improve occupant experience, wellbeing, engagement and customer retention



**SUSTAINABLE
DEVELOPMENT
GOALS**

7 AFFORDABLE AND
CLEAN ENERGY



11 SUSTAINABLE CITIES
AND COMMUNITIES



12 RESPONSIBLE
CONSUMPTION
AND PRODUCTION



What types of buildings do we serve best?



Hospitals



Schools



Social housing



Care homes



Municipality buildings



Hotels



Offices



Houses



Villas



Block of flats



Commercial buildings



Storage facilities

Successful stories



Optimizing retirement homes heating system in the UK

VOYTECH 

How IoT can help district heating improve energy consumption and management.

[LEARN MORE](#)

<https://mclimate.eu/pages/case-study-retirement-homes>



School buildings energy optimization in Denmark

Improving indoors climate for students with smart IoT solutions.

[LEARN MORE](#)

<https://mclimate.eu/pages/case-study-schools>



Office building energy management in Germany

Achieving ESG goals, starting with smart energy management.

[LEARN MORE](#)

<https://mclimate.eu/pages/case-study-german-bank>

LoRaWAN® Benefits



Long operational range

The wider the coverage, the better and cheaper the IoT infrastructure. With LoRaWAN®, the range is nearly 8 km in urban settings and 15 km in suburban areas.



Bidirectional communication

Fully bidirectional communication enables a wide variety of use cases requiring uplinks and downlinks. LoRaWAN® devices can deliver status messages even to remote locations.



Indoor penetration

The LoRa® waves can pass through obstacles and allow deep indoor penetration and adds the ability to reach sensors monitoring water or gas meters located underground.



Scalability

Wireless, easy to set up and able to support thousands of connected end-devices and millions of messages transmitted. Its fast deployment allows for large scale projects to come to life quicker and cheaper.



Long battery life of up to 10 years

Specifically designed to dramatically reduce the power consumption and extend the battery life, LoRaWAN® based data transmission and reception requires low current (less than 30 mA).



Open source standard

The LoRaWAN® standard is based on an open protocol approach managed by the LoRa® Alliance which supervises the development of the standard and ensures interoperability.



Low capex and opex

The LoRaWAN® open standard combined with cost-free operation frequencies and low-cost base stations allows operators to roll out networks quickly and with minimum investment.



High security

LoRaWAN® security design adheres to state-of-the-art principles: use of standard, well-vetted algorithms, and end-to-end security ensuring mutual authentication, integrity protection and confidentiality.

How it works?



Collect data

Sensors & Actuators

Transfer data

LoRaWAN® Gateway

Organize data

LoRaWAN® Network Server

Control & Monitor

IoT Platform

End-to-end encryption for Data security & integrity

Integrations with Network Providers



ThingPark Community



TEKTELIC communications



melita.io

machineQ™
A COMCAST COMPANY



Our products & Solutions

Our LoRaWAN® range is focused on sustainability, health and wellbeing and security - it aims to provide connected, smart and low carbon footprint buildings automation products and easily scalable retrofit solutions.

Energy Efficiency control & monitoring solution



Vicki LoRaWAN®



Wireless Thermostat LoRaWAN®



HT Sensor LoRaWAN®



Fan Coil Thermostat LoRaWAN®

Indoor air quality and health care solution



CO2 Sensor & Notifier LoRaWAN®



CO2 Display LoRaWAN®



CO2 Display Lite LoRaWAN®

Water control and damage prevention



T-Valve LoRaWAN®



Flood Sensor LoRaWAN®

Automation devices



Multipurpose Button LoRaWAN®



Open/Close Sensor LoRaWAN®



16A Switch & Power Meter LoRaWAN®



SOLUTION

Heating monitoring, analysis and control

Heating and cooling spaces accounts for up to 60% of a building's energy usage. Therefore, this should be the first item on anybody's list to make quick energy efficient win. But consuming less energy doesn't only mean you will save money and help reduce your CO2 impact on the Earth. We prove that it can also mean more precise temperature and humidity control as well as better comfort for occupants.

LEARN MORE

<https://mclimate.eu/pages/smart-buildings-heating>



SOLUTION

Actionable Indoor air quality and health care

Actionable is a key word. Our solution does not only send Indoor Air Quality and CO2 data for later analysis. Our solution also make sure occupants are visually and acoustically warned in a discrete manner if a room's air quality or CO2 is below standard, so occupants can take actions to improve it - e.g. ventilate. Feeling safe and acting responsibly on air quality has never been easier and it helps us reduce the spread of viruses in confined spaces.

LEARN MORE

<https://mclimate.eu/pages/smart-buildings-aqi>

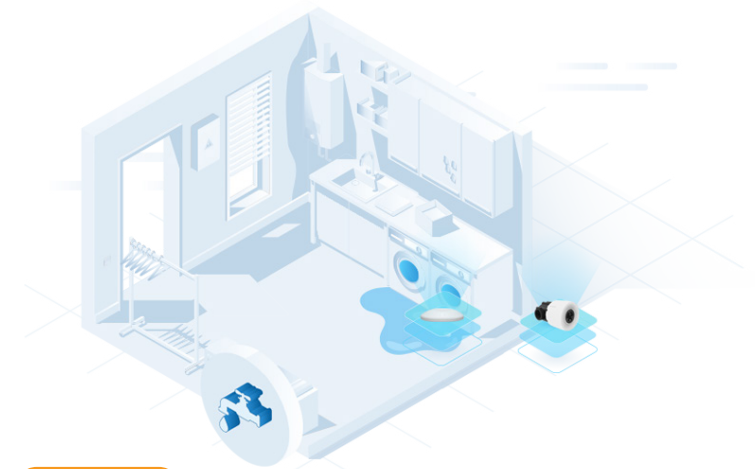

SOLUTION

Water control and damage prevention

Water damage can cost a fortune. Usually a flooding happens once, but when it does, it costs you time, money and effort to fix it. Our solution is a combination of two devices - a water valve (certified for drinking water) and flood sensor, both battery-operated. This allows you to not only know when there's a flood in your building, but also lets IoT take care of shutting off the water supply and minimizing the damage leaving nothing to chance and your insurance.

LEARN MORE

<https://mclimate.eu/pages/smart-buildings-water-control>

Vicki LoRaWAN®

MC-LW-V02

Vicki is a smart thermostatic radiator valve (TRV) retrofitting radiators with thermostatic valve and allowing for temperature control and monitoring from distance. Manual target temperature selection is possibly by rotating the outer ring of the device. The target temperature is displayed on the device.

Product features



- Manual adjustment of temperature
- 2-digits display
- Automatic temperature control algorithm
- Automatic temperature control algorithm with external temperature reading
- Manual valve openness control
- Open window detection
- Child lock
- Heating profiles/Schedules
- Geolocation
- Alarms
- Consumption reports
- Multiroom Control
- Family Accounts
- Smartphone & WEB control

Applications

Smart Buildings

Smart Home

Residential buildings

Commercial buildings

Energy optimization

Environment monitoring





Change and set temperature at home, wherever you are.



M Enterprise by MClimate

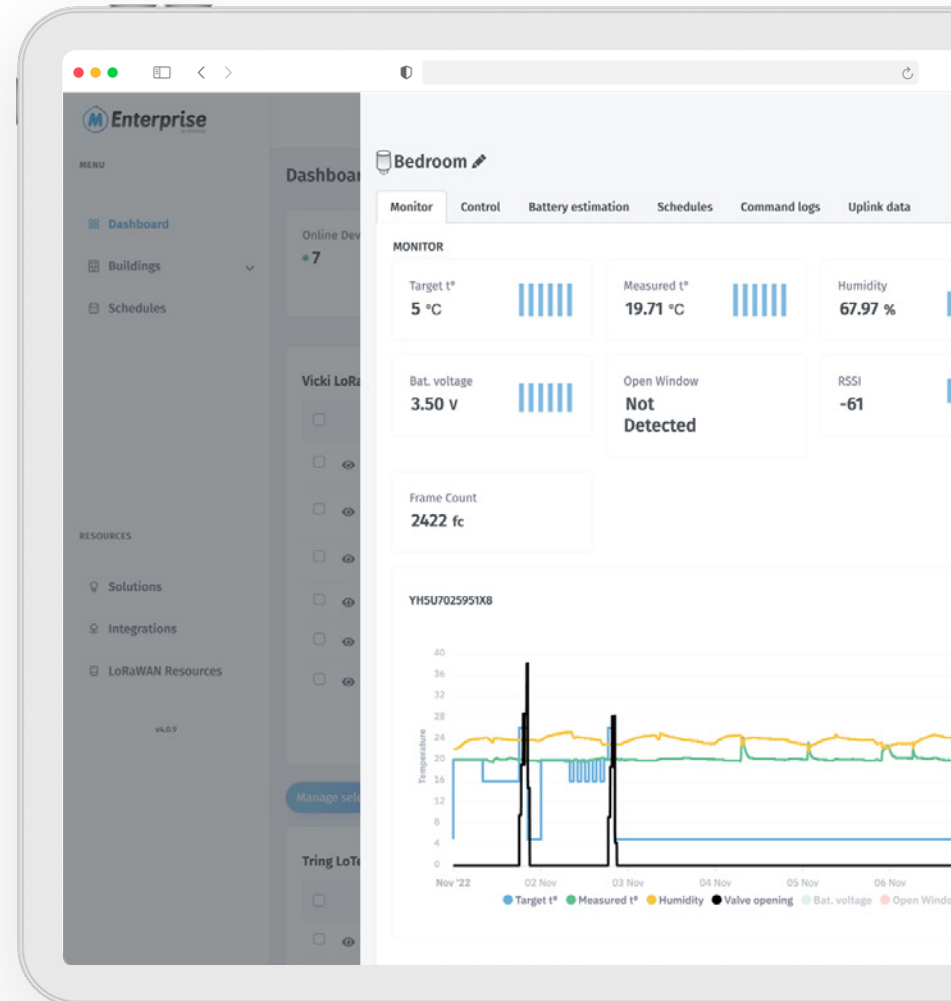

Dimensions

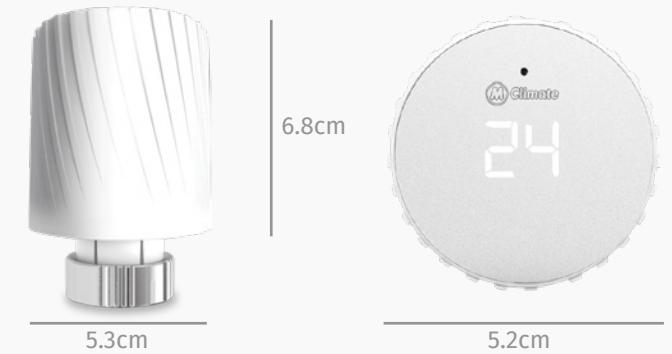

Compatibility

Vicki works seamlessly with district heating and thermostats. Compatible with M30x1.5M fitting and RA, RAV and RAVL Valve Adapters.

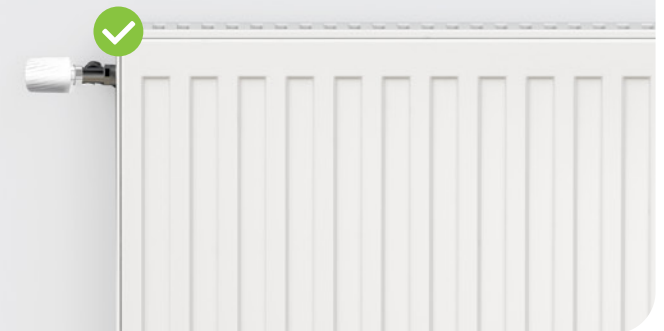

Technical Details

Design

ABS + PC reinforced with Glass Fibers, Anodised copper (metal nut)

Operating Conditions:

Temperature: - 20 - 60°C and Humidity: 0-80% RH (non-condensing)

Dimensions

54x78x50mm, 107gr

Battery Type

2 x AA with operating voltage 3 VDC

Battery life

10 years (depending on configuration and environment)

Wireless Technology

LoRaWAN® 1.0.3

Wireless Security

LoRaWAN® End-to-End encryption (AES-CTR)

Device Type

Class A End-device

Supported Features

OTAA , ADR , Adaptive Channels setup

How does it work?



Scan the QR code to access the full product specifications and API Documentations or visit the link: <https://mclimate.eu/pages/lorawan-resources>

HT Sensor LoRaWAN®

MC-LW-HT-01

MClimate HT Sensor LoRaWAN® is an indoor temperature and humidity sensor with 10+ years of battery life, configurable settings and beautiful and discreet design.

Product features



- Temperature sensor
- Humidity Sensor
- 2xAA Power supply
- Alarms
- Analytics
- Smartphone and WEB control.

Applications

Smart Buildings

Smart Home

Residential buildings

Commercial buildings

Energy optimization

Environment monitoring





Monitor temperature & humidity
at home, wherever you are.

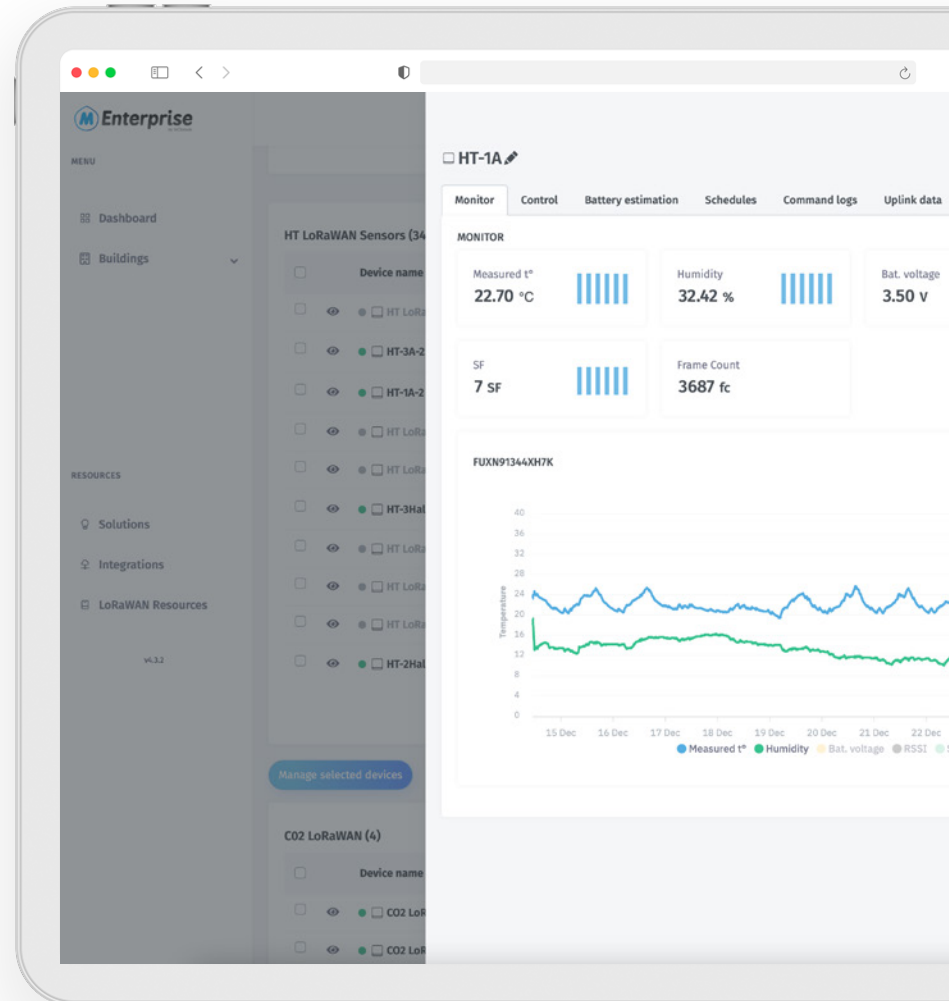
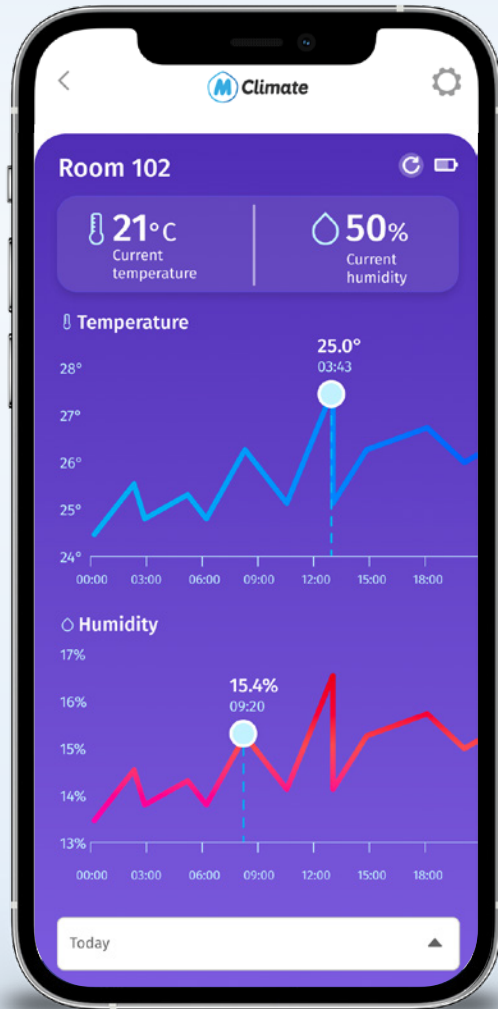

Dimensions

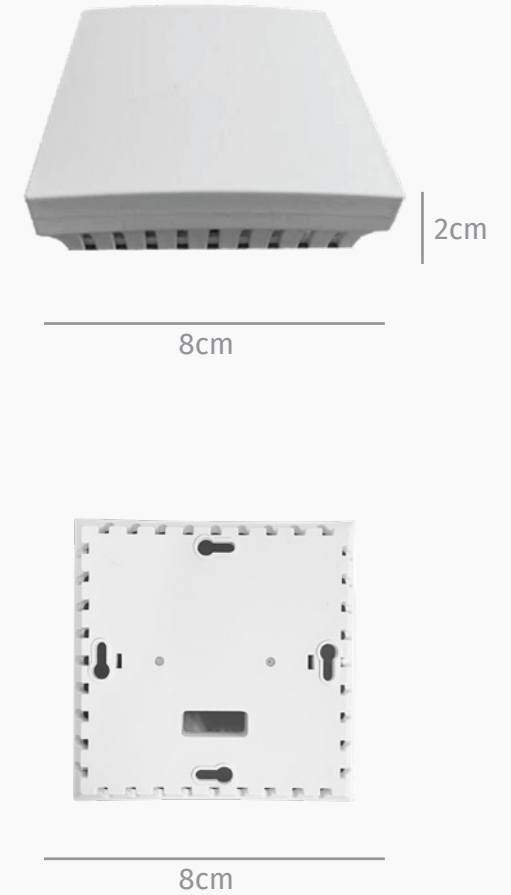

Technical Details

Design

ABS

Operating Conditions:

Temperature: - 20 - 60°C and Humidity: 0-80% RH (non-condensing)

Dimensions

80x80x20mm, 68gr

Battery Type

2 x AA with operating voltage 3 VDC

Battery life

10 years (depending on configuration and environment)

Wireless Technology

LoRaWAN® 1.0.3

Wireless Security

LoRaWAN® End-to-End encryption (AES-CTR)

Device Type

Class A End-device

Supported Features

OTAA , ADR , Adaptive Channels setup

How does it work?



Scan the QR code to access the full product specifications and API Documentations or visit the link: <https://mclimate.eu/pages/lorawan-resources>

MClimate Wireless Thermostat LoRaWAN®

MC-LW-WT-01

MClimate Wireless Thermostat is a stand-alone thermostat entirely by solar energy using an organic solar panel. The device features a 2.9" e-ink screen, sensor for movement (PIR), temperature and humidity sensor, LUX sensor and 3 buttons. The user can change the target temperature and see current indoor conditions. The device sends an uplink after any event as well as periodically. The data from the Wireless Thermostat can be used in any LoRaWAN-compatible system, incl. Building Management Systems to control different appliances in the building.

Product features



- Temperature sensor
- Humidity Sensor
- 4xAA Power supply/USB Type-C
- Alarms
- E-ink display
- Organic solar panel
- Motion sensor
- Lux meter
- Analytics
- FUOTA
- Smartphone and WEB control

Applications

Smart Buildings

Smart Home

Residential buildings

Commercial buildings

Energy optimization

Environment monitoring





Change and set temperature at home, wherever you are.

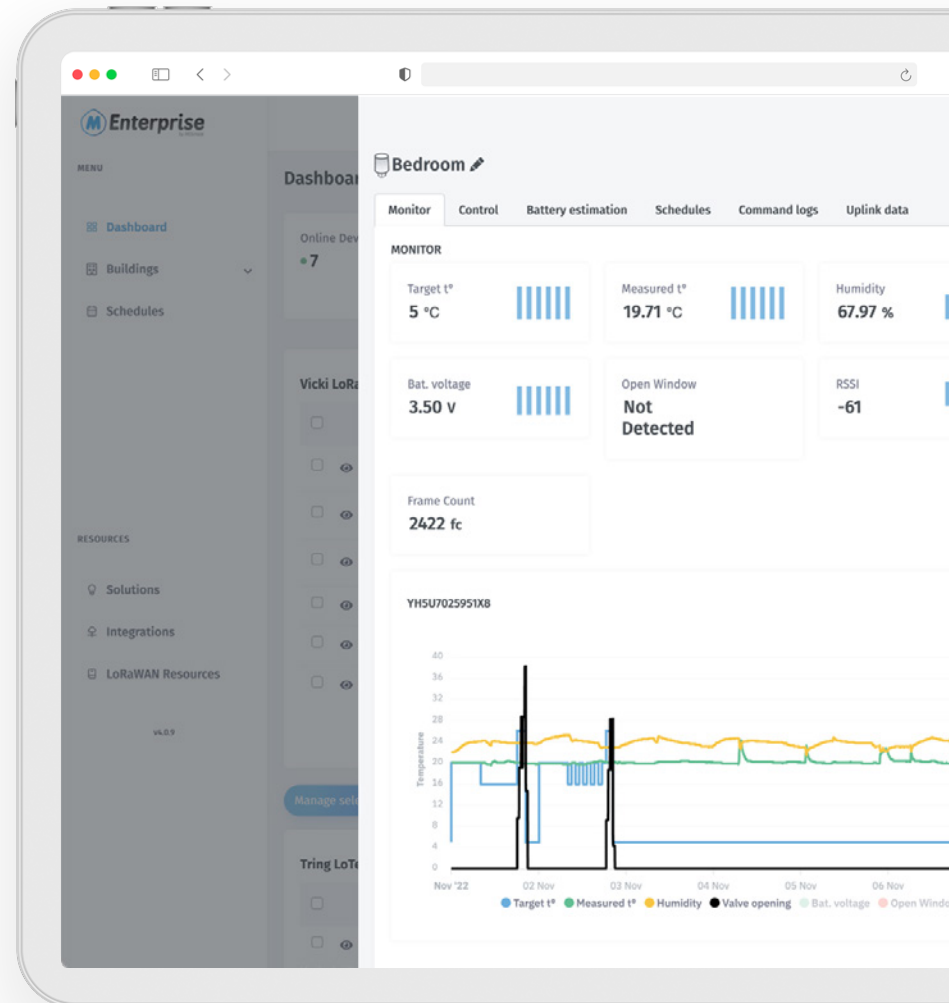
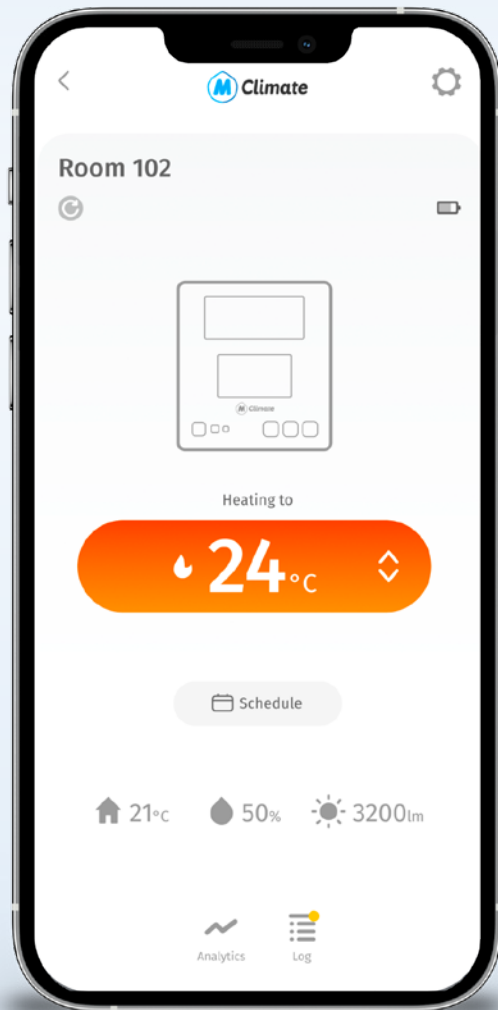

Dimensions



10.5 cm

11.5 cm

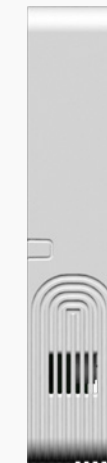

10.5 cm

2.3 cm

Technical Details

Design

ABS, Stainless steel, tampered glass

Operating Conditions:

Temperature: 0° - +50°C and Humidity: 0-80% RH (non-condensing)

Dimensions

105mm X 115mm X 23mm, 170gr

Power supply

Solar-powered Lithium-ion capacitor (LIC) AND/OR 4xAA 1.5VDC batteries AND/OR USB-C

Battery life

10 years (depending on configuration and environment)

Wireless Technology

LoRaWAN® 1.0.3

Wireless Security

LoRaWAN® End-to-End encryption (AES-CTR)

Device Type

Class A End-device

Supported Features

OTAA , ADR , Adaptive Channels setup

How does it work?



Scan the QR code to access the full product specifications and API Documentations or visit the link: <https://mclimate.eu/pages/lorawan-resources>

MClimate Fan Coil Thermostat LoRaWAN®

MC-LW-FCT-01

The Fan Coil Thermostat (FCT) is a LoRaWAN device for 2- and 4-pipe Fan Coil Units, accommodating 3-speed or ECM fans. Ideal for building retrofitting, it enhances energy efficiency and reduces heating/cooling expenses significantly. With its 4.2" e-ink fast refresh display it allows the end-users to change the target temperature and see current indoor conditions. Its fully open and transparent communication protocol allows seamless integration into different systems including MClimate Enterprise platform.

Product features



- Firmware Upgrade Over The Air (FUOTA)
- Compatible with 2-pipe and 4-pipe FCUs
- Compatible with ECM or 3 speed fans
- Temperature and Humidity sensor
- 4.2" e-ink fast-refresh display
- Anti-theft stainless steel bracket
- Multipurpose Analog/Digital Input/Output (pipe temperature monitoring; external contact - e.g. door/window sensor or hotel card occupancy; dew point sensor; filter alarm)
- Simple 4 buttons interface - ON/OFF/Mode, Increase temp; Decrease Temp, Select FAN speed.
- Keys lock (select which keys are disabled)

Applications

Smart Buildings

Smart Home

Residential buildings

Commercial buildings

Hotels





Change and set temperature at home, wherever you are.

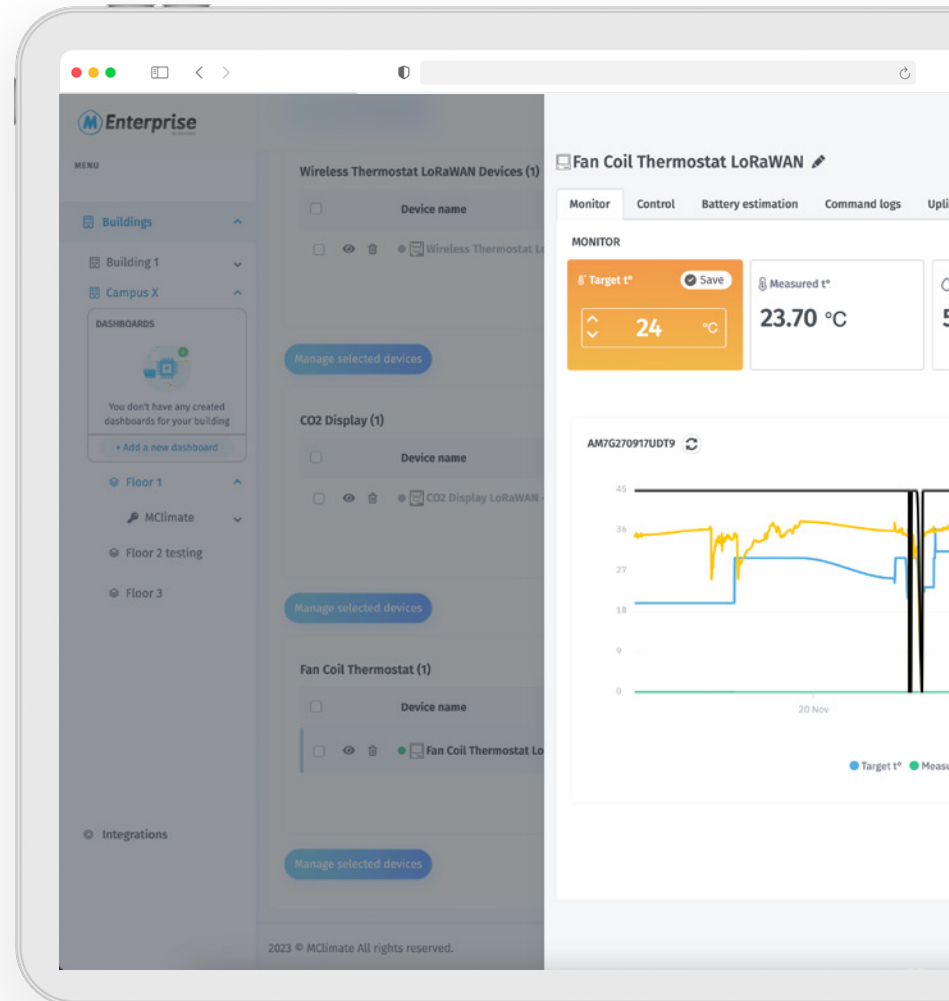

Dimensions



10.5 cm

11.5 cm



10.5 cm

2.3 cm

Technical Details

Design

ABS, Stainless steel, tampered glass

Operating Conditions:

Temperature: 0° - +50°C and Humidity: 0-80% RH (non-condensing)

Dimensions

105mm X 115mm X 23mm, 170gr

Power supply

110-230VAC

Consumption

50mA MAX

Wireless Technology

LoRaWAN® 1.0.3

Wireless Security

LoRaWAN® End-to-End encryption (AES-CTR)

Device Type

Class A End-device

Supported Features

OTAA , ADR , Adaptive Channels setup

How does it work?



Scan the QR code to access the full product specifications and API Documentations or visit the link: <https://mclimate.eu/pages/lorawan-resources>

CO2 Sensor LoRaWAN®

MC-LW-CO2-01

MClimate CO2 Sensor and Notifier is a device that uses NDIR technology to measure the actual CO2 and has built-in temperature and humidity sensors. The device also has acoustic and visual notification abilities to indicate occupants whether a room should be ventilated.

Product features



- CO2 Sensor (NDIR)
- Temperature Sensor
- Humidity Sensor
- RGB LED
- Acoustic Buzzer
- 2xAA Power supply
- Ultra-low power consumption
- Alarms
- Analytics
- Family Accounts
- Smartphone & WEB control

Applications

Smart Buildings

Smart Home

Residential buildings

Commercial buildings

Energy optimization

Environment monitoring





Monitor CO2 at home,
wherever you are.



M Enterprise

by MClimate

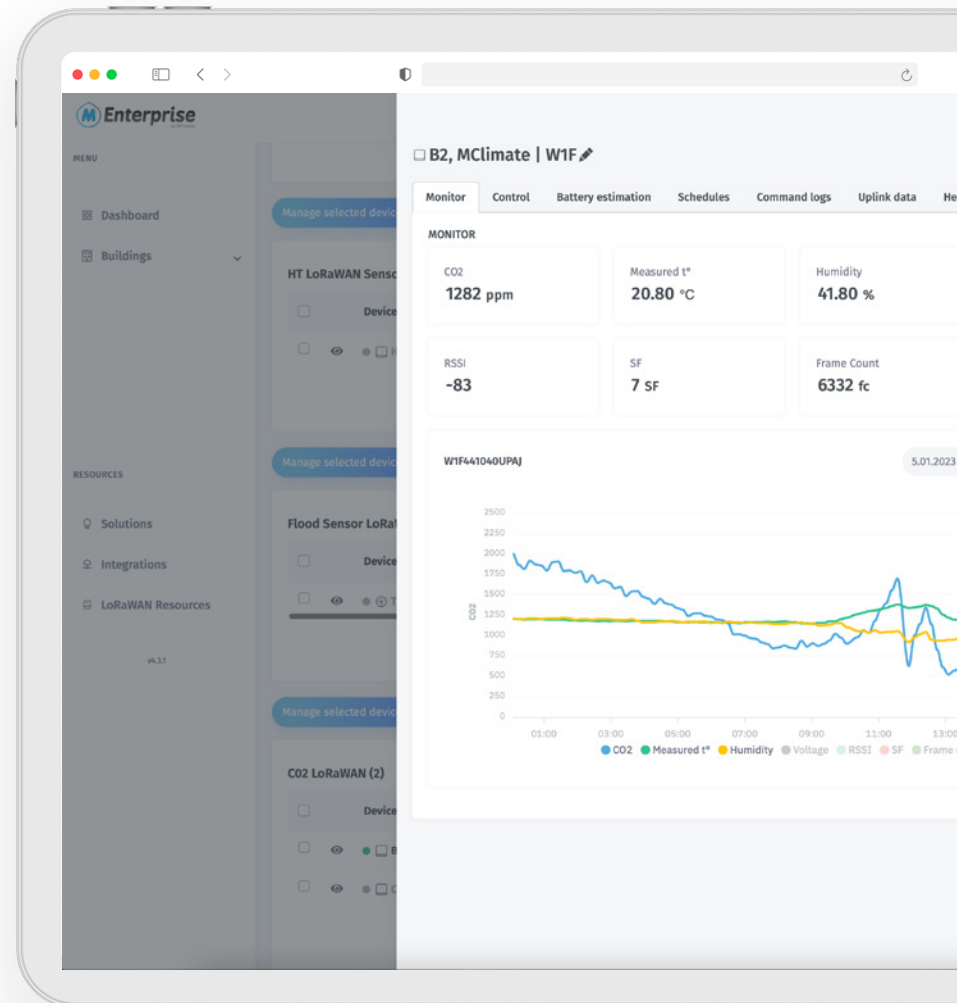

Dimensions



2 cm

8 cm

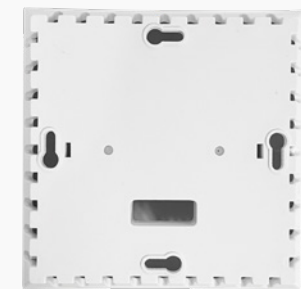

8 cm

Technical Details

Design

ABS

Operating Conditions:

Temperature: - 20 - 60°C and Humidity: 0-80% RH (non-condensing)

Dimensions

80x80x20mm, 68gr

Battery Type

2 x AA with operating voltage 3 VDC

Battery life

10 years (depending on configuration and environment)

Wireless Technology

LoRaWAN® 1.0.3

Wireless Security

LoRaWAN® End-to-End encryption (AES-CTR)

Device Type

Class A End-device

Supported Features

OTAA , ADR , Adaptive Channels setup

How does it work?



Scan the QR code to access the full product specifications and API Documentations or visit the link: <https://mclimate.eu/pages/lorawan-resources>

CO2 Display LoRaWAN®

MC-LW-CO2-E-INK-01

MClimate CO2 Display LoRaWAN® is a stand-alone CO2 sensor powered entirely by solar energy using an organic solar panel. The device features a 2.9" e-ink screen, sensor for movement (PIR), temperature and humidity sensor, LUX sensor and NDIR CO2 sensor. The user can see the current levels of CO2 as well as historical trend. The device sends an uplink when it detects movement as well as periodically. The data from the CO2 Display can be used in any LoRaWAN® compatible system, incl. Building Management Systems to control demand-based ventilation. Sensor information can be exposed as datapoints in Modbus, BACnet and KNX systems through the use of a special gateway.

Product features



- CO2 Sensor (NDIR)
- Temperature sensor
- Thermostat
- Humidity Sensor
- 4xAA Power supply/USB Type-C
- Alarms
- E-ink display
- Organic solar panel
- Motion sensor
- Lux meter
- Analytics
- FUOTA
- Smartphone and WEB control

Applications

Smart Buildings

Smart Home

Residential buildings

Commercial buildings

Energy optimization

Environment monitoring





Monitor CO2 at home,
wherever you are.

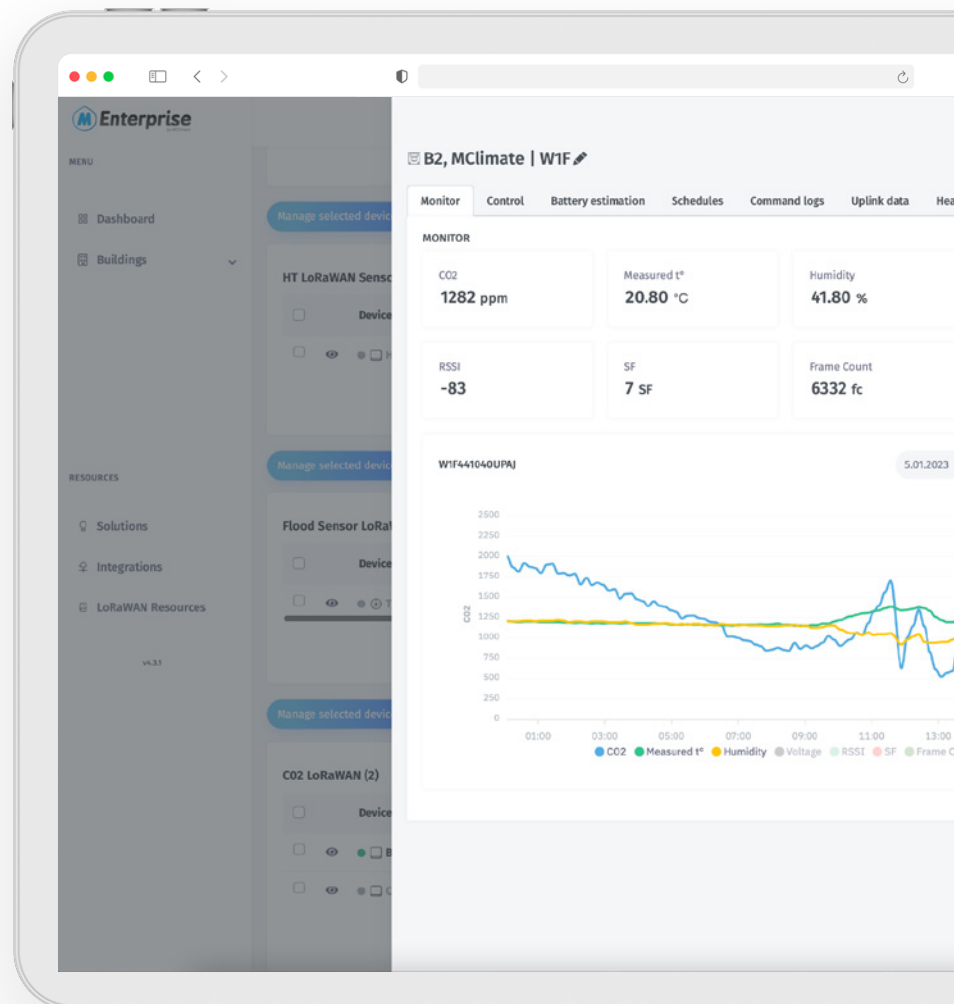

Dimensions



11.5 cm



2.3 cm

Technical Details

Design

ABS, Stainless steel, tampered glass

Operating Conditions:

Temperature: 0° - +50°C and Humidity: 0-80% RH (non-condensing)

Dimensions

105mm X 115mm X 23mm, 170gr

Power supply

Solar-powered Lithium-ion capacitor (LIC) AND/OR 4xAA 1.5VDC batteries AND/OR USB-C

Battery life

10 years (depending on configuration and environment)

Wireless Technology

LoRaWAN® 1.0.3

Wireless Security

LoRaWAN® End-to-End encryption (AES-CTR)

Device Type

Class A End-device

Supported Features

OTAA , ADR , Adaptive Channels setup

How does it work?



Scan the QR code to access the full product specifications and API Documentations or visit the link: <https://mclimate.eu/pages/lorawan-resources>

CO2 Display Lite

LoRaWAN®

MC-LW-LITE-CO2-E-INK-01

MClimate CO2 Display lite LoRaWAN is a stand-alone CO2 sensor powered entirely by solar energy using an organic solar panel. The device features a 2.9" e-ink screen, sensor for movement (PIR), temperature and humidity sensor, LUX sensor and NDIR CO2 sensor. The user can see the current levels of CO2 as well as historical trend. The device sends an uplink when it detects movement as well as periodically. The data from the CO2 Display can be used in any LoRaWAN compatible system, incl. Building Management Systems to control demand-based ventilation. Sensor information can be exposed as datapoints in Modbus, BACnet and KNX systems through the use of a special gateway.

Product features



- Solar-powered & battery free
- LUX sensor
- 1.54" e-ink display
- Temperature and Humidity sensor
- NDIR CO2 sensor
- Anti-theft bracket
- FUOTA

Applications

Smart Buildings

Smart Home

Residential buildings

Commercial buildings

Energy optimization

Environment monitoring





Monitor CO2 at home, wherever you are.

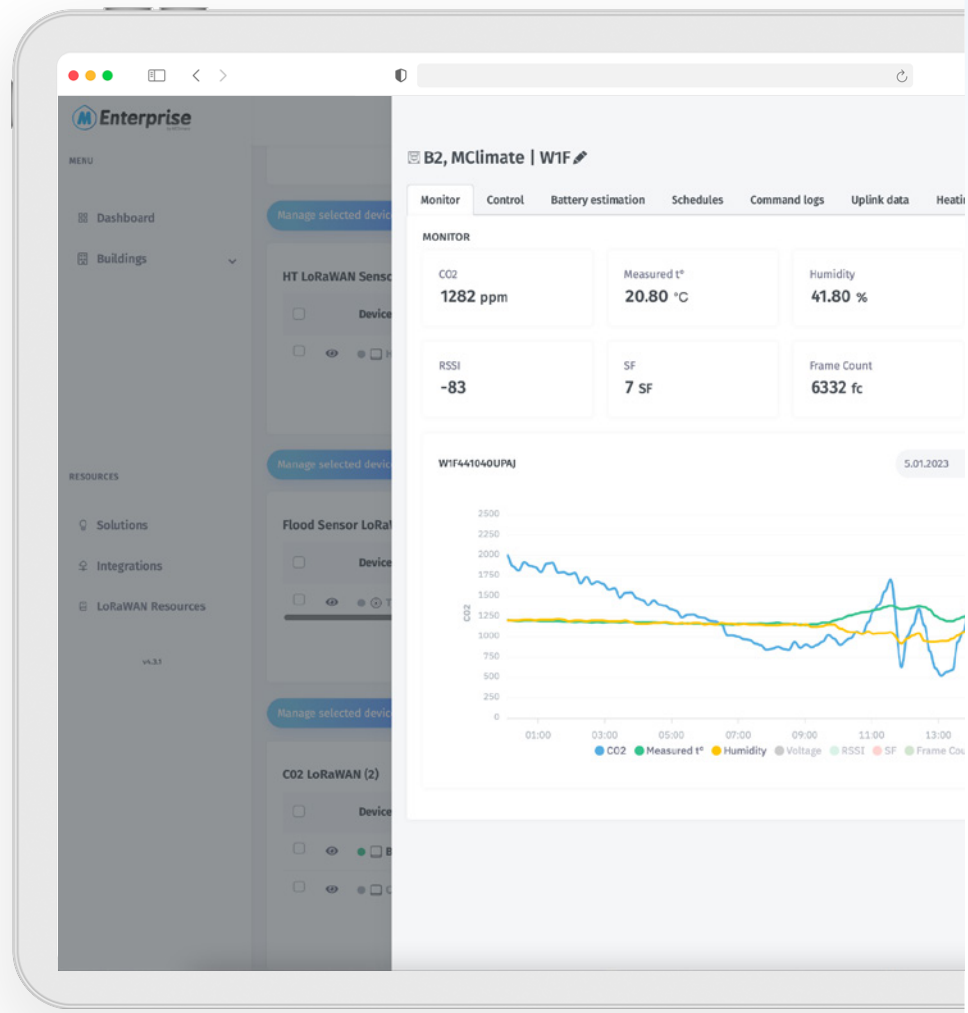

Dimensions

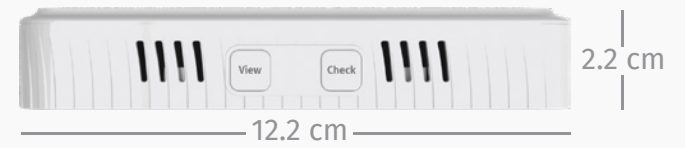
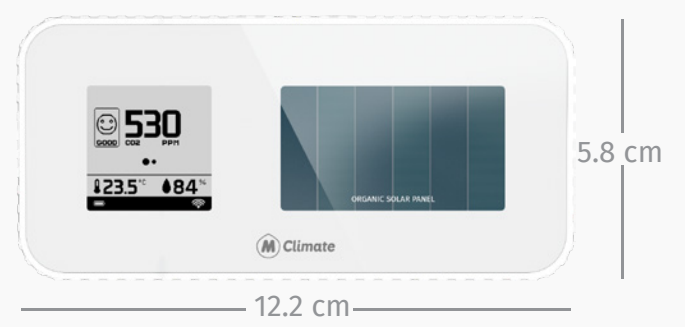

Technical Details

Design

ABS, Stainless steel, tampered glass

Operating Conditions:

Temperature: 0° - +50°C and Humidity: 0-80% RH (non-condensing)

Dimensions

122mm x 58mm x 22mm, 80gr

Power supply

Solar-powered Lithium-ion capacitor (LIC)
AND/OR USB-C

Battery life

Indefinite powered by solar

Wireless Technology

LoRaWAN® 1.0.3

Wireless Security

LoRaWAN® End-to-End encryption (AES-CTR)

Device Type

Class A End-device

Supported Features

OTAA , ADR , Adaptive Channels setup

How does it work?



Scan the QR code to access the full product specifications and API Documentations or visit the link: <https://mclimate.eu/pages/lorawan-resources>

T-Valve LoRaWAN®

MC-LW-T-VALVE-01

T-Valve is a LoRaWAN® water valve used in residential or commercial buildings. 3/4" and 1" versions available. T-Valve gives you the opportunity to stop a potential water damage from happening, by being able to control the main water supply in your property from distance. No more floods and damages.

Product features



- 3/4" and 1" versions available for remote water supply control
- Water temperature
- Environment temperature
- Wired Flood Sensor (optional)
- Housing tampering detection
- Magnetic tampering detection
- Buttons for manual control
- LEDs for valve and device status indication Buzzer
- Alarms
- Analytics
- Smartphone and WEB control

Applications

Smart Buildings

Smart Home

Residential buildings

Commercial buildings

Energy optimization

Environment monitoring





Monitor your home from anywhere in the world and prevent leaks and damages.

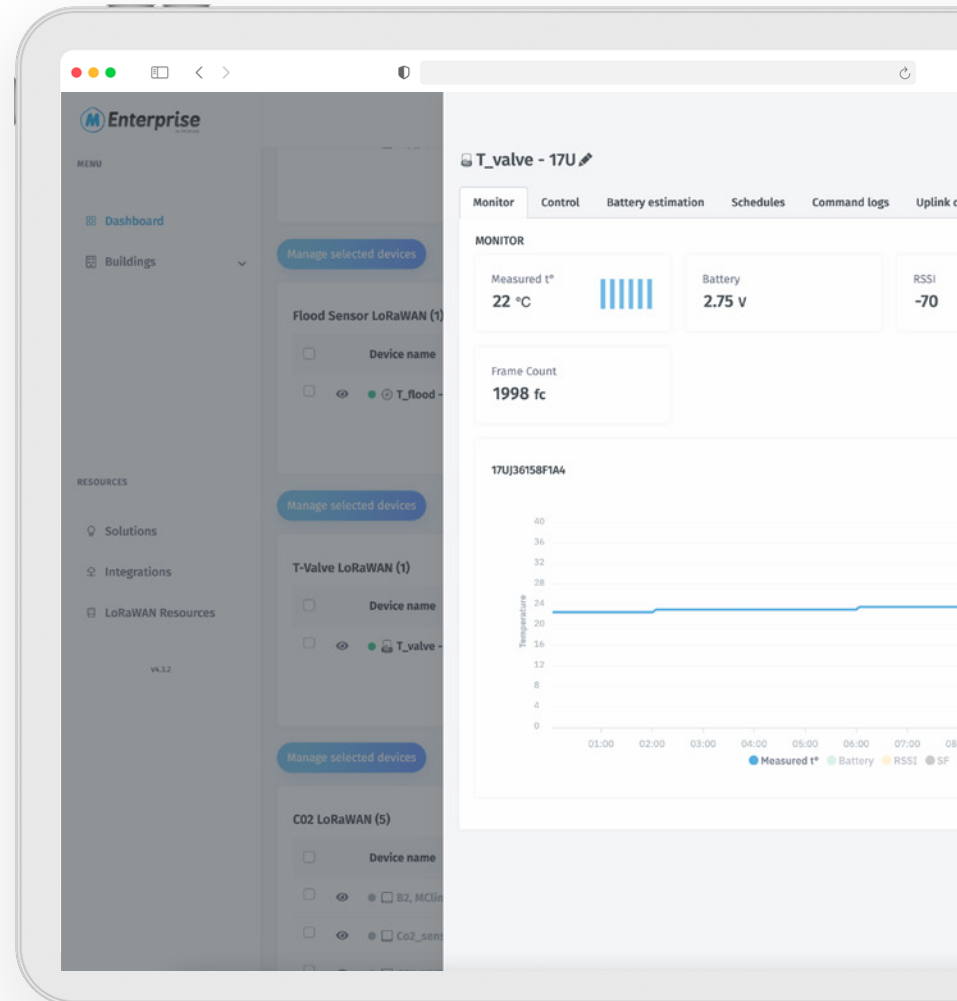
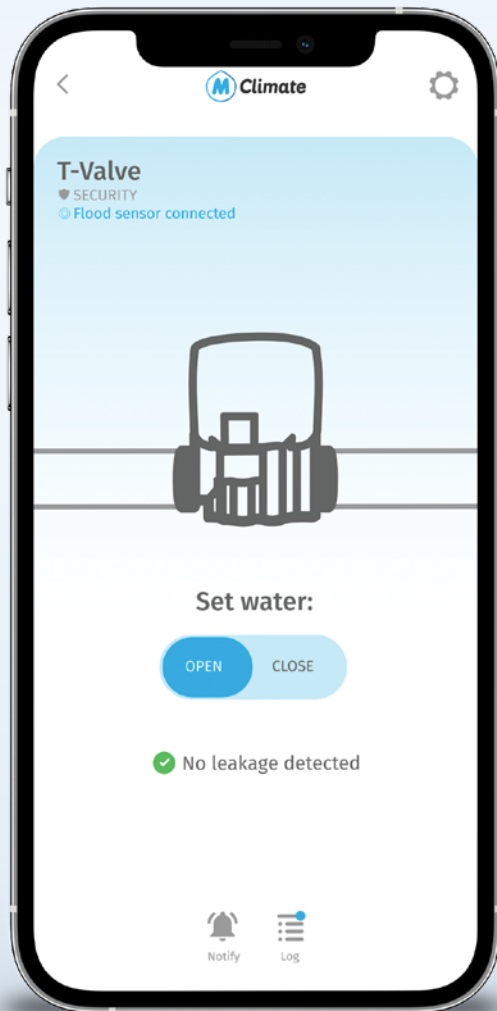

Dimensions

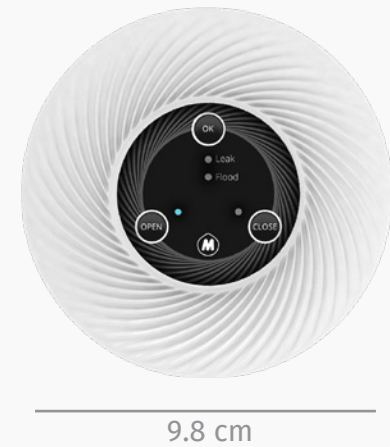

Technical Details

Design

PC/ABS; Valve PPE/PS

Operating Conditions:

Temperature: - 0 - 60°C and Humidity: 35%-90% RH (non-condensing)

Dimensions

105x117x90,8mm, 557gr

Battery Type

LiSO Cl2 ER26500 3.6V 9000mAh

Battery life

10 years (depending on configuration and environment)

Wireless Technology

LoRaWAN® 1.0.3

Wireless Security

LoRaWAN® End-to-End encryption (AES-CTR)

Device Type

Class A End-device

Supported Features

OTAA , ADR , Adaptive Channels setup

How does it work?



Scan the QR code to access the full product specifications and API Documentations or visit the link: <https://mclimate.eu/pages/lorawan-resources>

Flood Sensor

LoRaWAN®

MC-LW-Flood

MClimate Flood Sensor is a compact flood sensor suitable for residential and commercial applications. If a flood is detected, data is immediately transmitted.

Product features



- Flood detection
- Device tampering detection
- Temperature sensor
- Buzzer
- LED
- Alarms
- Analytics
- Smartphone and WEB control

Applications

Smart Buildings

Smart Home

Residential buildings

Commercial buildings

Energy optimization

Environment monitoring

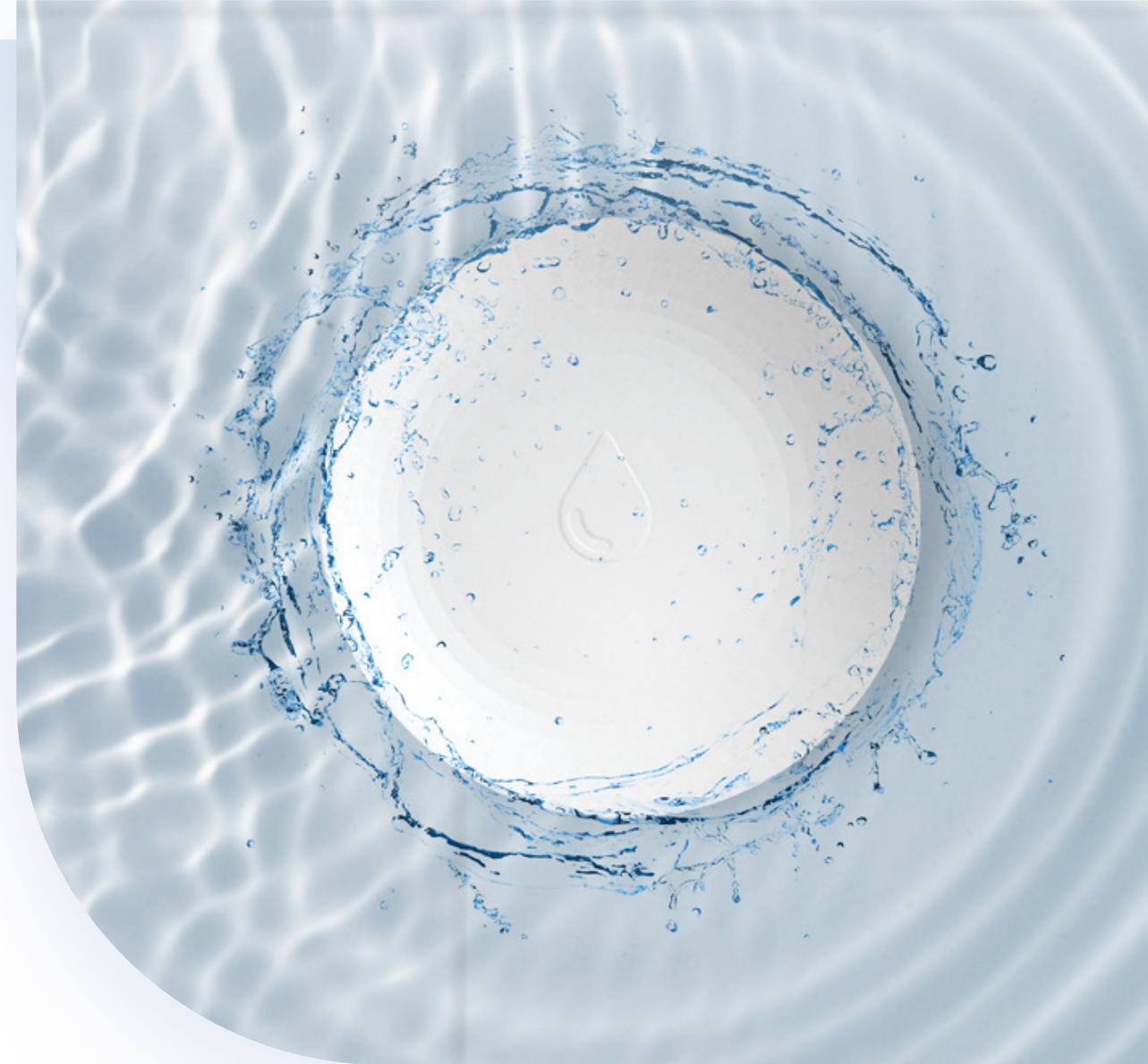



Monitor your home from anywhere in the world and detect flood.

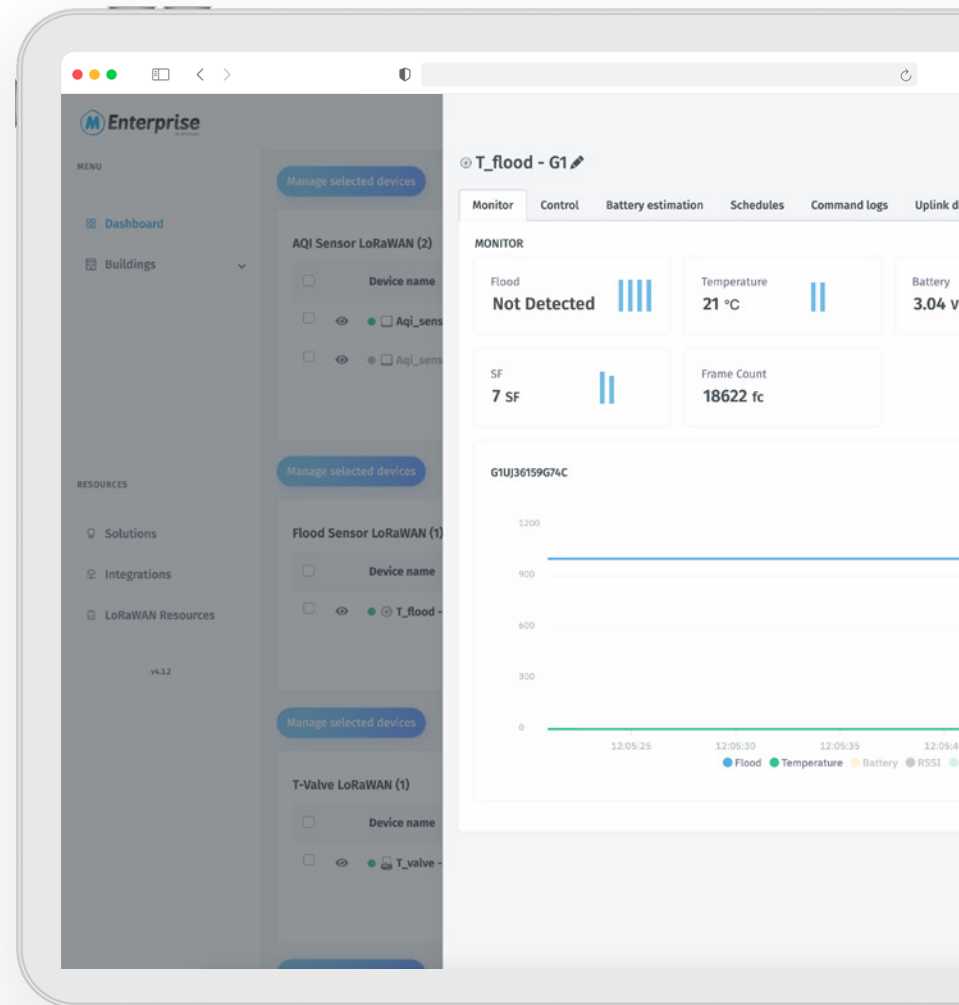
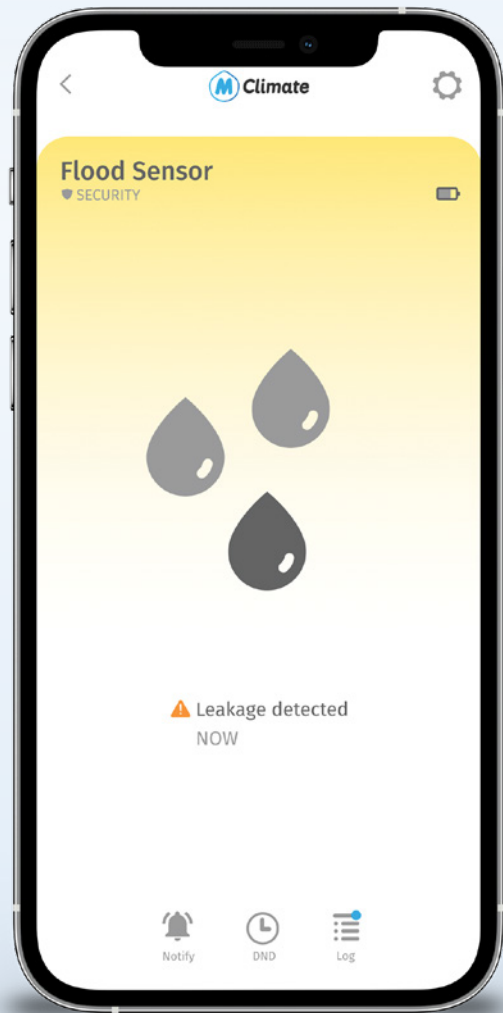

Dimensions



7 cm



7 cm

1.9 cm

Technical Details

Design

ABS

Operating Conditions:

Temperature: - 20 - 60°C and Humidity: 0-80% RH (non-condensing)

Dimensions

70x70x19mm, 33gr

Battery Type

CR123A, operating voltage: 3VDC

Battery life

10 years (depending on configuration and environment)

Wireless Technology

LoRaWAN® 1.0.3

Wireless Security

LoRaWAN® End-to-End encryption (AES-CTR)

Device Type

Class A End-device

Supported Features

OTAA , ADR , Adaptive Channels setup

How does it work?



Scan the QR code to access the full product specifications and API Documentations or visit the link: <https://mclimate.eu/pages/lorawan-resources>

Multipurpose Button LoRaWAN®

MC-LW-BTN-01

MClimate Multipurpose Button LoRaWAN® is a simple device with many applications. Featuring a single button with 3 types of clicks and a temperature sensor, only your imagination limits what happens when the customer presses the button.

Product features



- Button with 3 click types (single, double and triple)
- Temperature sensor
- Ultra-low power consumption
- Alarms
- Schedules
- Smartphone and WEB control

Applications

Smart Buildings

Smart Home

Residential buildings

Commercial buildings

Energy optimization

Environment monitoring





Control Multipurpose
Button wherever you are.

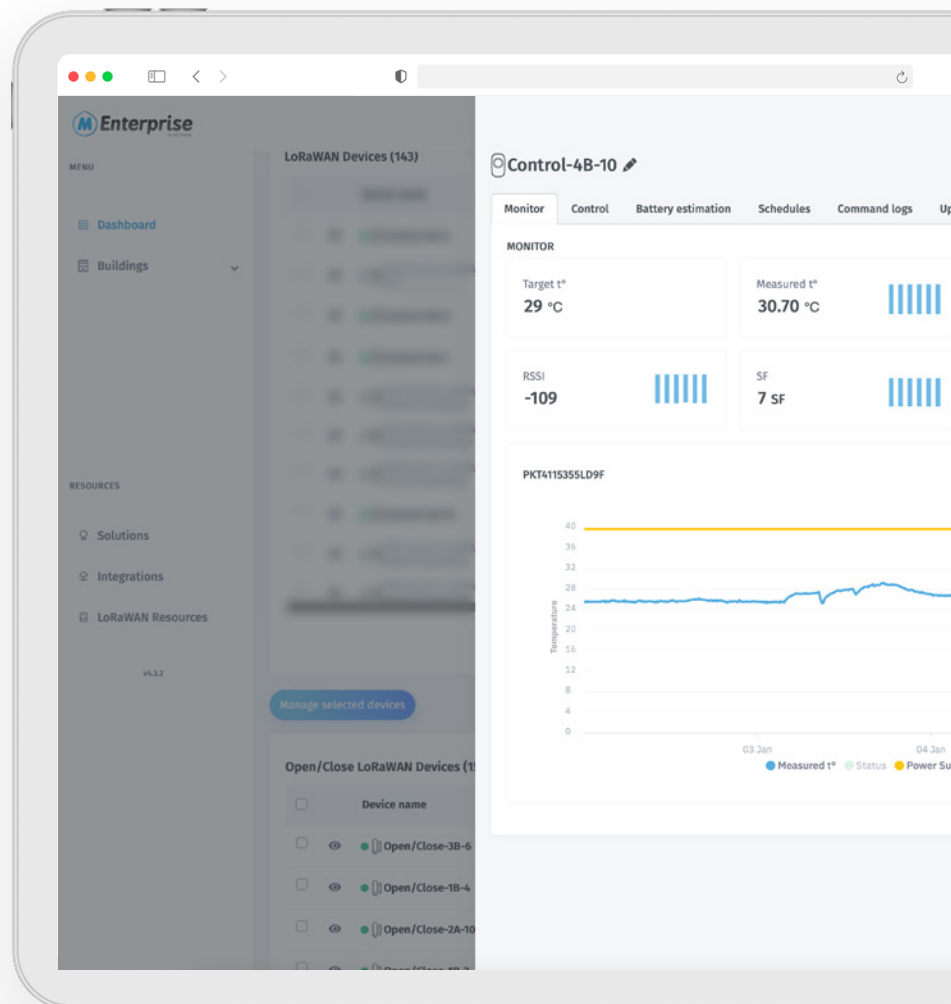

Dimensions



Technical Details

Design

ABS

Operating Conditions:

Temperature: 0 - +50°C and Humidity: 0-80% RH (non-condensing)

Dimensions

71x41x18mm, 26gr

Battery Type

ER10280 with operating voltage 3 VDC

Battery life

< 10 years (depending on configuration and environment)

Wireless Technology

LoRaWAN® 1.0.3

Wireless Security

LoRaWAN® End-to-End encryption (AES-CTR)

Device Type

Class A End-device

Supported Features

OTAA , ADR , Adaptive Channels setup

How does it work?



Scan the QR code to access the full product specifications and API Documentations or visit the link: <https://mclimate.eu/pages/lorawan-resources>

Open/Close Sensor LoRaWAN®

MC-LW-OC-01

MClimate Open/Close Sensor LoRaWAN® is a device detecting the event of opening or closing windows, doors, cabinets and more. It features long battery life, LED, temperature sensor and a button that triggers an uplink. The device sends an uplink for every event of opening/closing and keeps an internal counter of the total number of events.

Product features



- Magnetic reed
- Switch button
- Temperature sensor
- ER14250 or 1/2 AA Power supply
- Smartphone and WEB control

Applications

Smart Buildings

Smart Home

Residential buildings

Commercial buildings

Energy optimization

Environment monitoring





Monitor Open/Close Sensor
wherever you are.

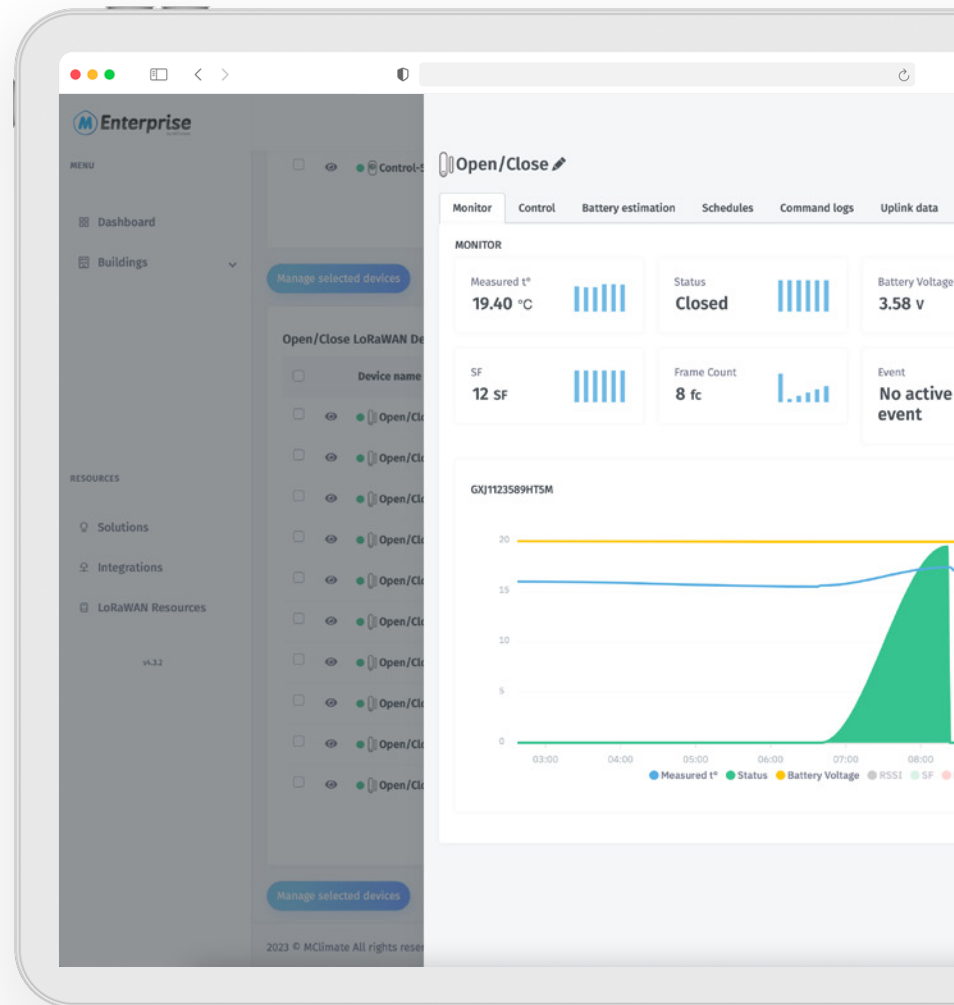
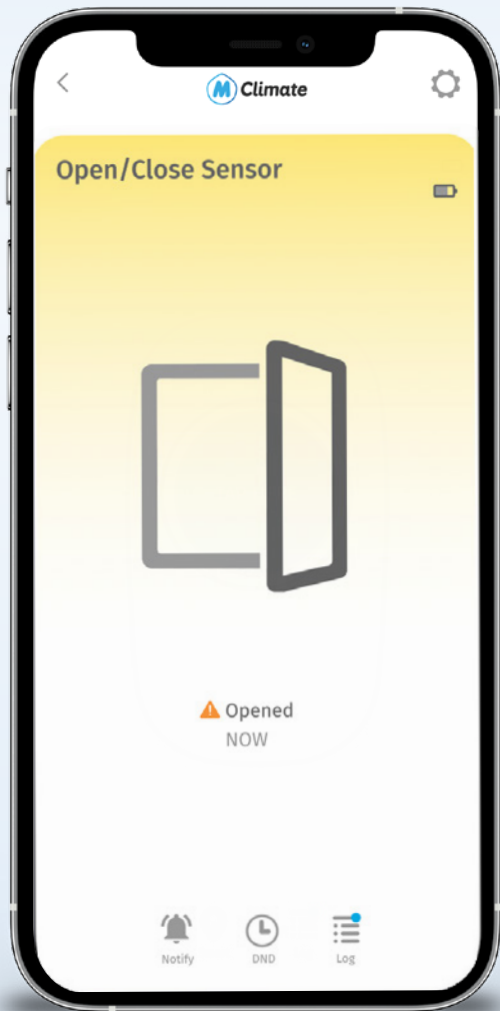

Dimensions



Technical Details

Design

ABS

Operating Conditions:

Temperature: 0 - +50°C and Humidity: 0-80% RH (non-condensing)

Dimensions

Main unit: 72x20x20mm; Magnet: 50x10x15mm

Battery Type

ER10280 with operating voltage 3 VDC

Battery life

< 10 years (depending on configuration and environment)

Wireless Technology

LoRaWAN® 1.0.3

Wireless Security

LoRaWAN® End-to-End encryption (AES-CTR)

Device Type

Class A End-device

Supported Features

OTAA , ADR , Adaptive Channels setup

How does it work?



Scan the QR code to access the full product specifications and API Documentations or visit the link: <https://mclimate.eu/pages/lorawan-resources>

16A Switch & Power Meter LoRaWAN®

MC-LW-16ASPM-01

The MClimate 16A Switch & Power Meter LoRaWAN® is a compact 16A relay and electricity meter. The device is small enough to fit behind most wall switches and power equipment, enabling you to automate, track, and control your electrical appliances. This is possible as the device has 4 terminals L, N, N, Lout, and it works in a way that connects and disconnects Lout from L. With an overheating protection mechanism, FUOTA (Firmware Upgrades Over The Air), and operation in LoRaWAN Class C, the MClimate 16ASPM is ideal for rapid building retrofitting.

Product features



- Firmware Upgrade Over The Air
- Electricity Meter
- Voltage Meter
- Current Meter
- Internal temperature sensor and overheating protection

Applications

Smart Buildings

Smart Home

Residential buildings

Hotels

Commercial buildings

Energy optimization





Control Electrical Power
wherever you are.

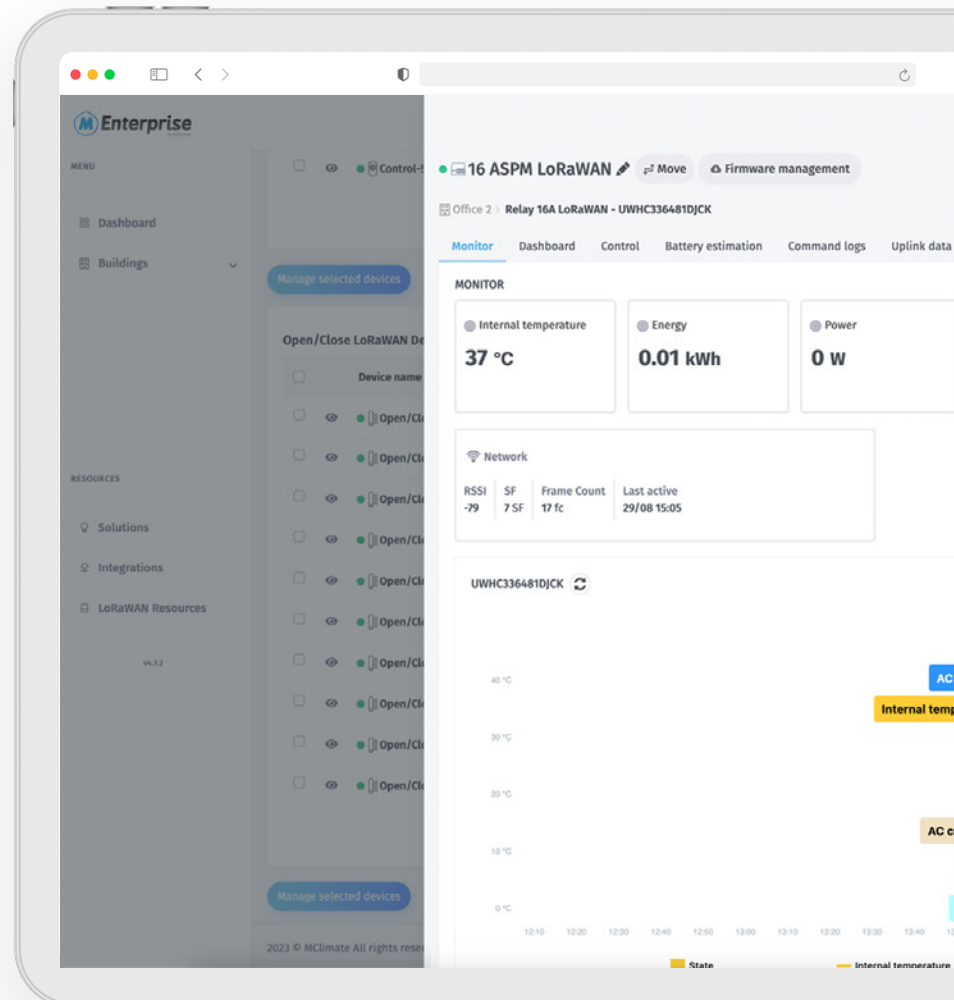
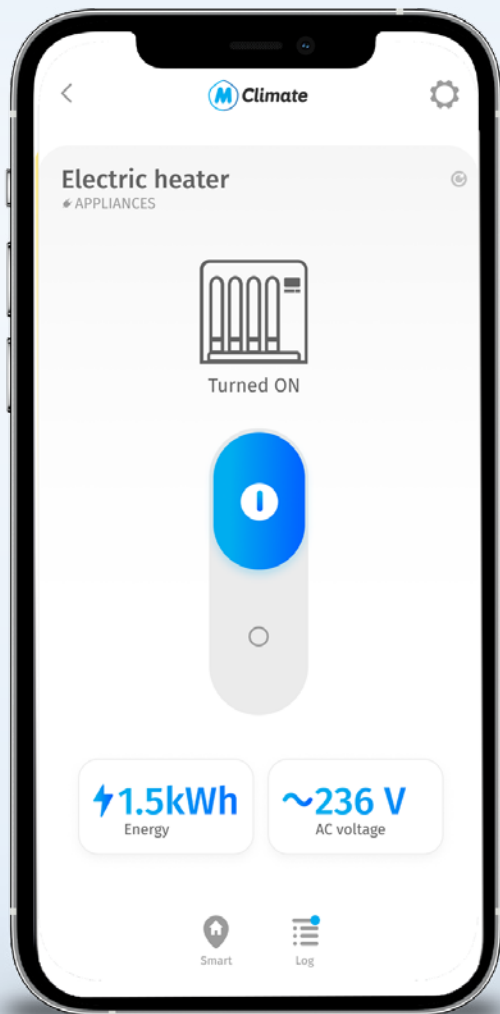

Dimensions

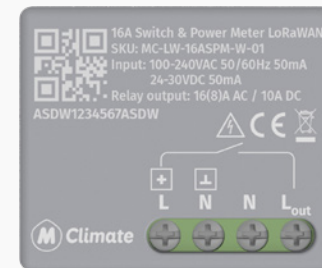

3.2 cm

3.6 cm

1.8 cm

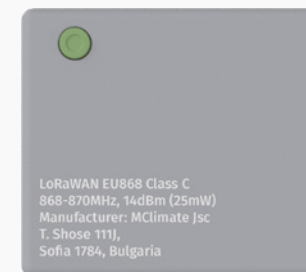

Technical Details

Design

PC UL-94 V0

Operating Conditions:

Temperature: -10 - +60°C and Humidity: 0-80% RH (non-condensing)

Dimensions

32mm x 36mm x 18mm, 24.5gr

Power supply

100-240VAC / 24-30VDC

Consumption

50mA

Wireless Technology

LoRaWAN® 1.0.3

Wireless Security

LoRaWAN® End-to-End encryption (AES-CTR)

Device Type

Class C End-device

Supported Features

OTAA , ADR , Adaptive Channels setup

How does it work?

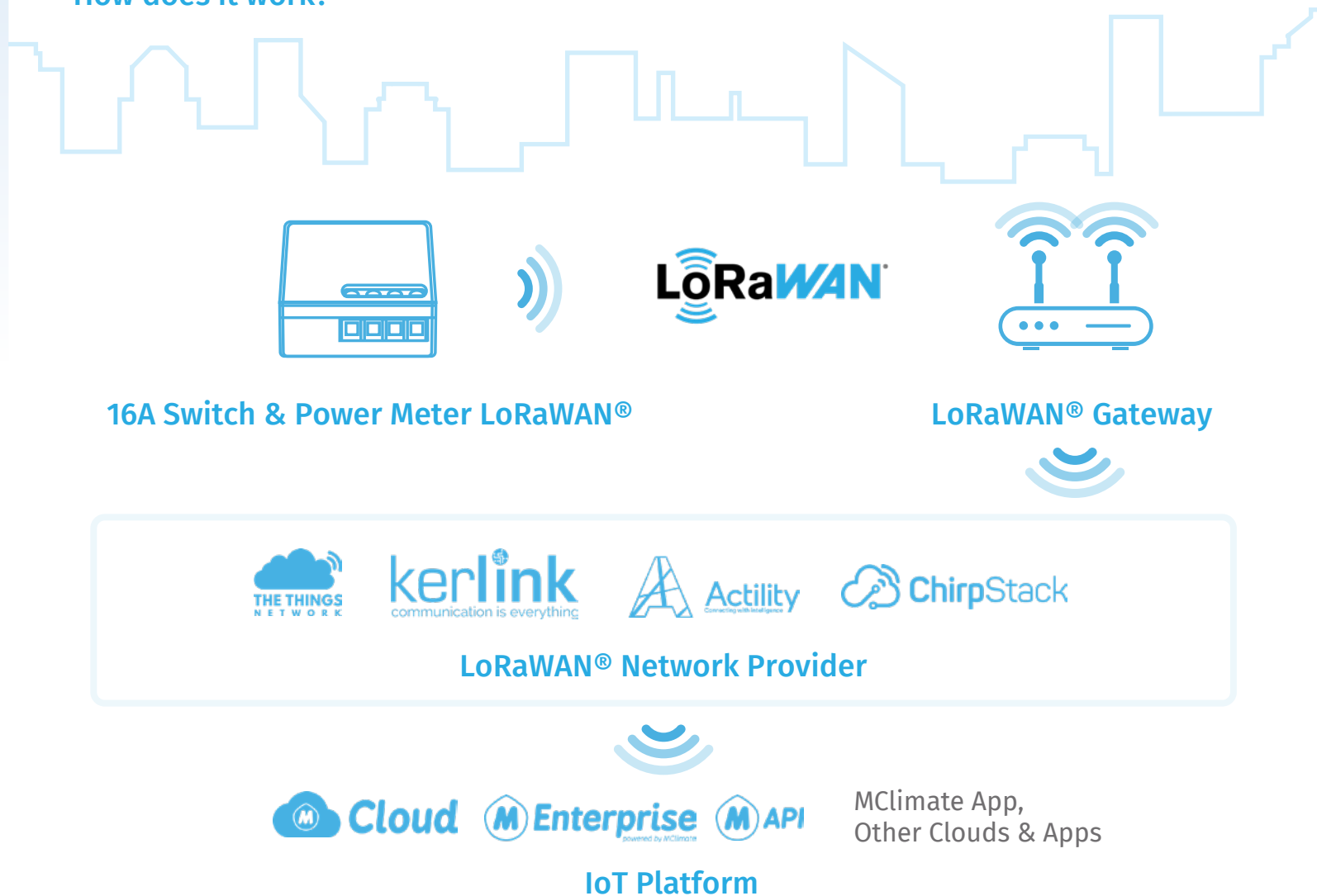

Scan the QR code to access the full product specifications and API Documentations or visit the link: <https://mclimate.eu/pages/lorawan-resources>

Powerful Building Management Platform



MClimate Enterprise is an integrated solution for smart automation of the heating/cooling, security and safety infrastructure of large apartment complexes, office buildings and hotels. The appliances used for your heating/cooling needs can perform better, optimize comfort and reduce energy consumption by up to 30%. MClimate offers a product line of Energy and Security devices compatible with your split and multi-split A/C's, water heaters, radiators and major electric appliances. With the centralized management WEB interface, your building management officers can monitor and control remotely all smart devices unit-by-unit, room-by-room, or the whole infrastructure simultaneously.

Features:

- Create a digital twin of your building (including floors, apartments & offices, rooms)
- User management - give limited access to each user to specific assets
- Floor map view - upload your floor plan and view your devices on a map
- Subscription management and invoices
- Create custom dashboards with selected devices
- Receive daily, weekly, monthly reports on specific assets on your email
- Rule engine - create custom rules and actions

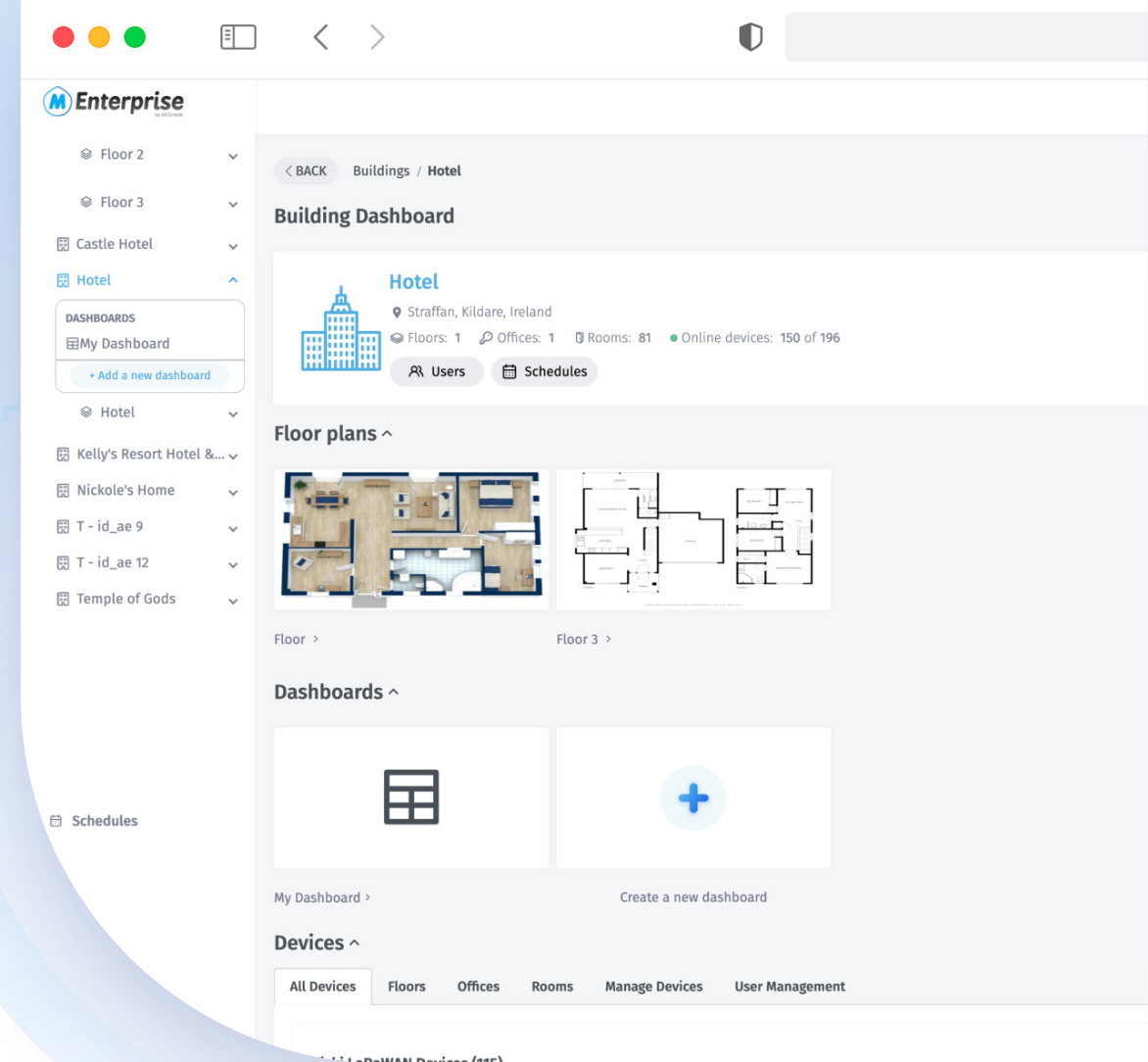

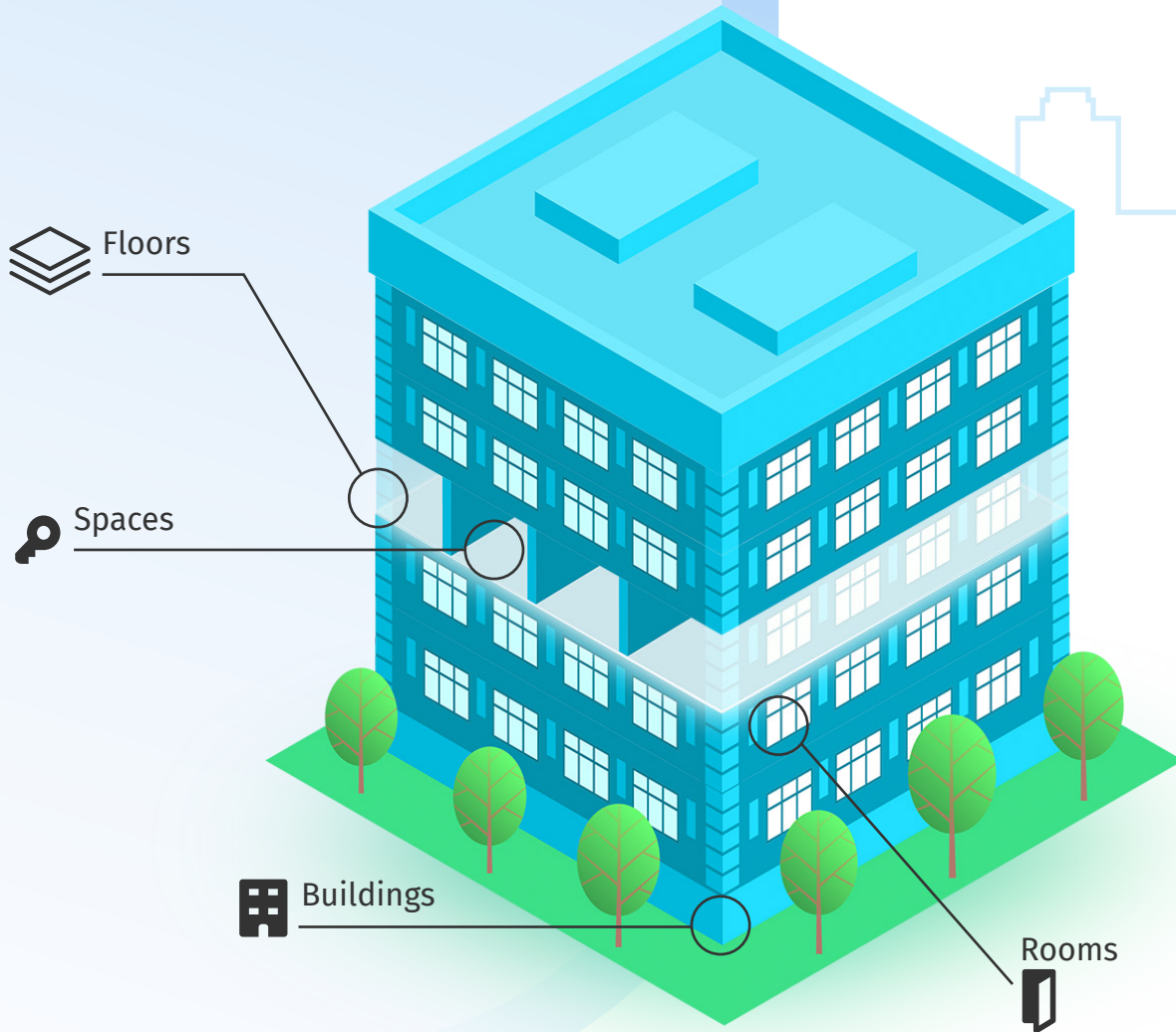

Digital twin of your building

Creating a digital twin of your building has numerous advantages. Once everything has its' digital replica, you will be able to get a better understanding of your building and how one thing interacts with another. In MClimate Enterprise, you are able to re-create your building floor by floor and room by room. You can assign devices to a specific location in the building as well as retrieve analytics for a specific asset e.g. floor.

Applications

Smart Buildings

Smart Home

Residential buildings

Commercial buildings

Energy optimization

Environment monitoring

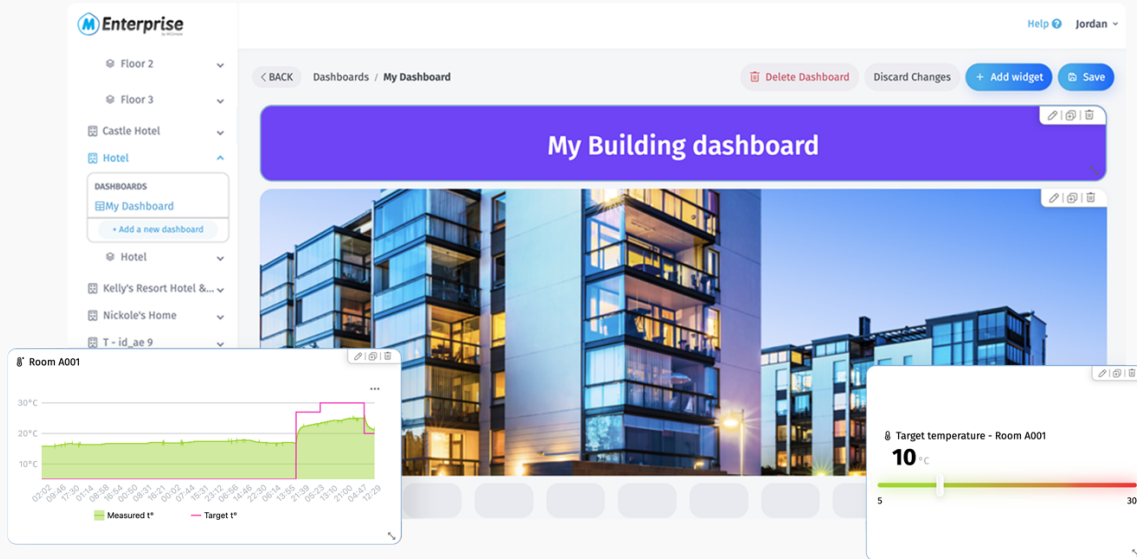

Custom dashboards

Easily create custom dashboards with the data you are most interested in. The dashboards offer a variety of widgets. Once you select a widget, you can resize it, move it to a different location, change colors and much more.

Floor map view

Navigate your building visually by creating customized floor plans. Get device information quickly and control them from a single place.

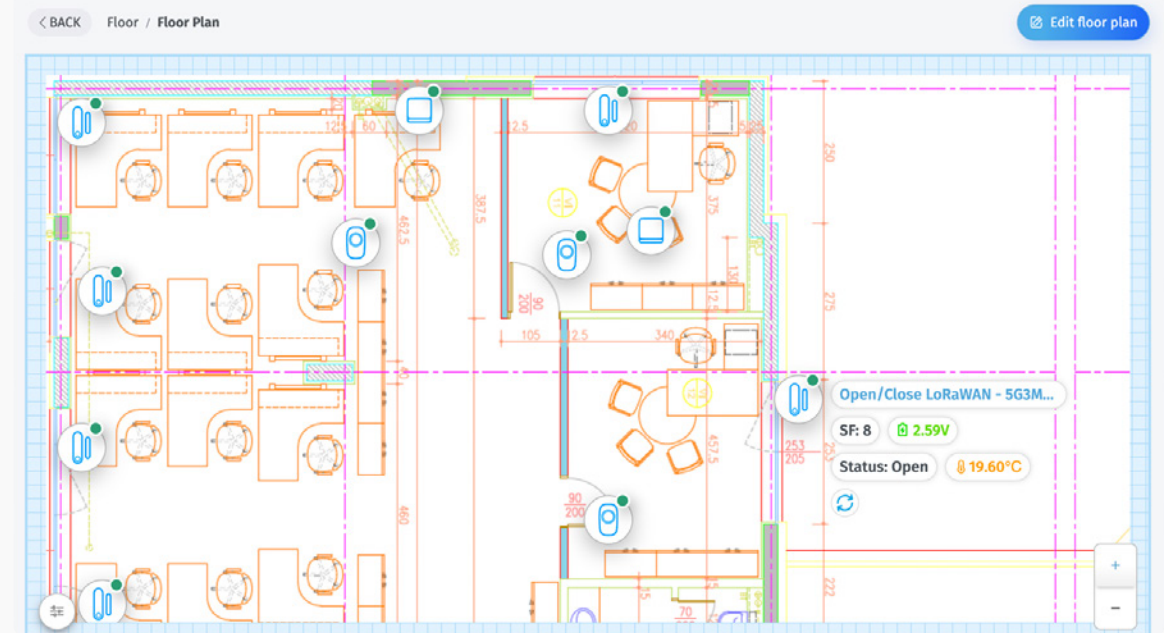

Create **Manage devices**

Name

Visibility

Building 1

Schedule

Monday Tuesday Wednesday Thursday Friday Saturday Sunday

15C 21C

02:00 03:00 15:30 16:00

02:00 - 03:00 15C

15:30 - 16:00 21C

Time slot

Starts 15:30 Ends 16:00 T°C 21

Add a new time slot

Heating profiles

Heating profiles allow you to create numerous different profiles and assign them to devices in your building. If you change the profile, all devices that follow it, will change. If your clients are using MClimate Home app, heating profiles are a great way to monitor their individual settings, offer support and also suggest them profiles that might save energy.

Analytics

Informed decisions are based on data. That's why we make it super easy for you to see live or historical data about your devices and their performance. Easily spot trends, extract detailed reports and more.

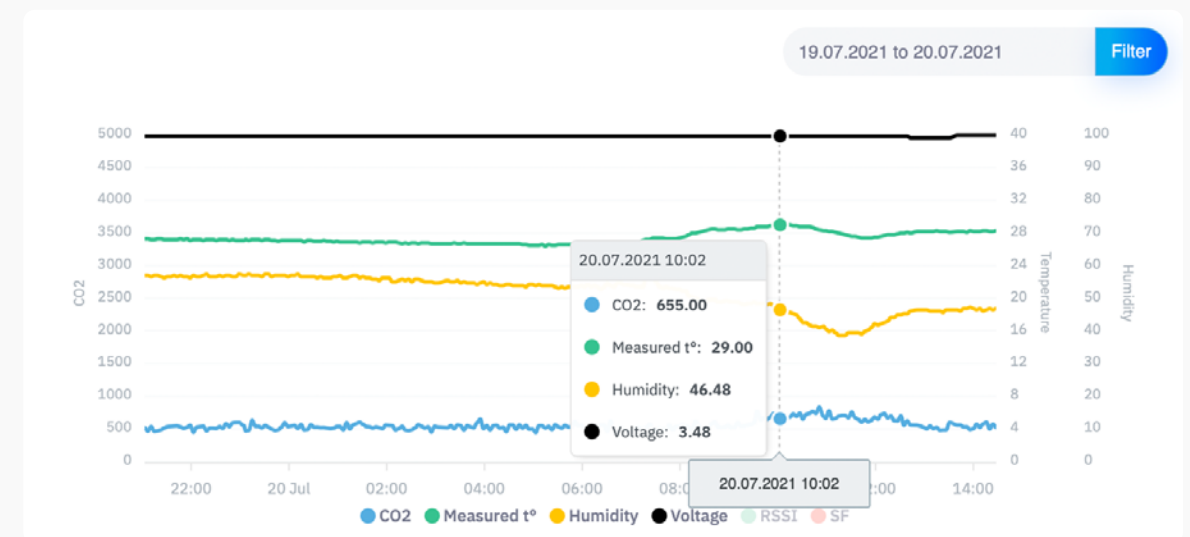

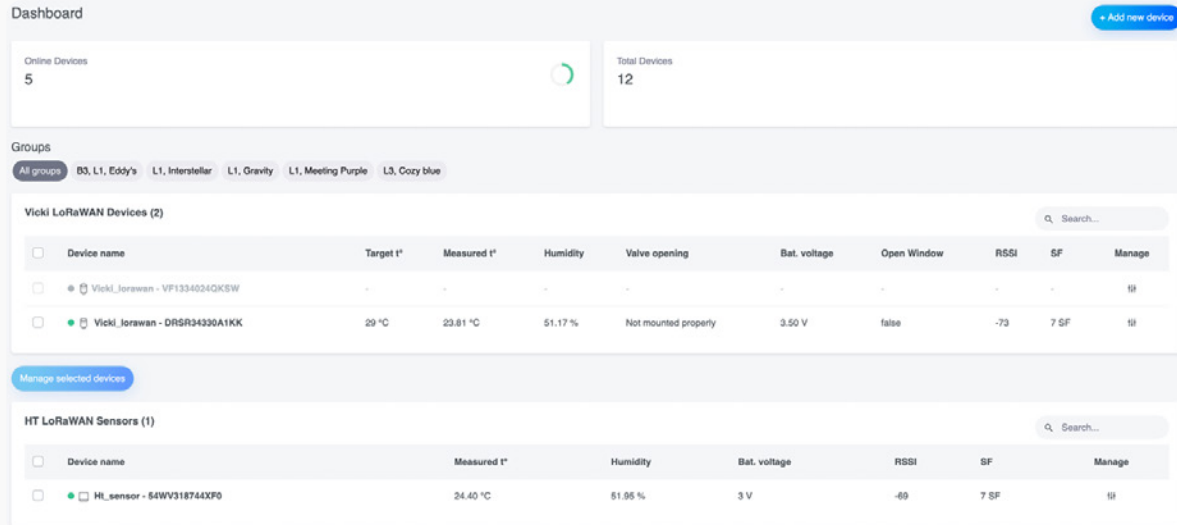

Control assets

Control your all MClimate devices in your building from a the central dashboard, where you get an overview of the most important metrics about your building and also can drill-down to control and see more data. Filter the devices by buildings/floors/rooms, etc. to get a clear overview of a specific part of your building.

User management

Easily manage user access to any of your assets. For example, you can give someone admin rights to a whole building or moderator rights to just a floor inside the building or you can e.g. give end-user access to only 1 apartment or room. Admins have full rights, moderators have full rights except for managing subscriptions.

Add new user to Floor 1 / Campus X ✕

Email

Select role

- Admin
- Moderator
- End-User



Scan the QR code to learn more about MClimate Enterprise or just visit the link below:

<https://mclimate.eu/pages/enterprise>

Utilities

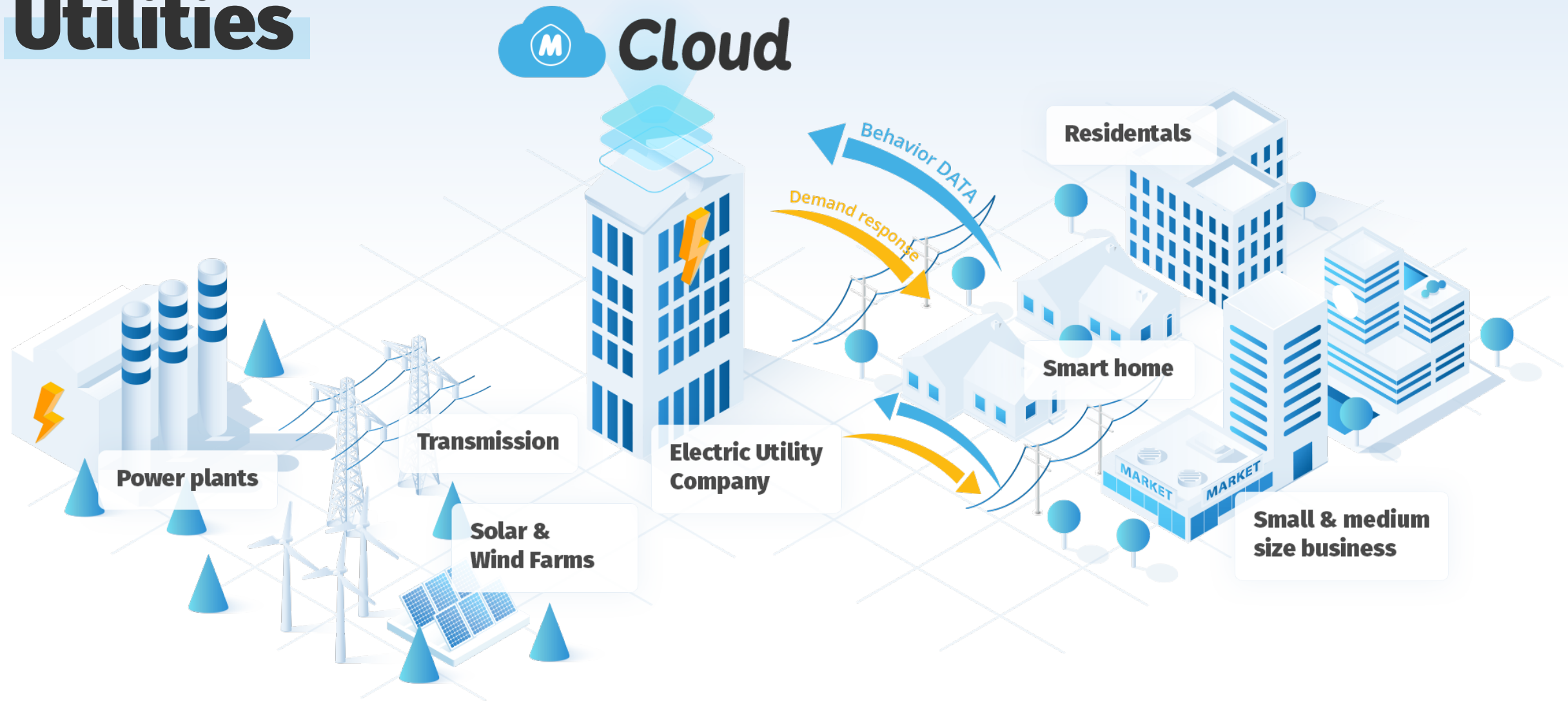

Existing smart meters are far away from giving consumers the "smart home experience" - some of the most intriguing opportunities in the sector are in service and products extending beyond the meter, where consumers interact with their energy use. MClimate offers smart home capabilities and consumer services with an entirely new set of capabilities that many utilities have not adequately developed. Utilities success in this domain will require strong partnerships to design and offer accessible services from the customer perspective outwards.

Utilities. Key benefits.

Lorem ipsum dolor sit amet, consectetur adipiscing elit, sed do eiusmod tempor incididunt ut labore et dolore magna aliqua. Ut enim ad minim veniam, quis nostrud exercitation ullamco laboris nisi ut aliquip ex ea commodo consequat. Duis aute irure dolor in reprehenderit in voluptate velit esse cillum dolore eu fugiat nulla pariatur. Excepteur sint occaecat cupidatat non proident, sunt in culpa qui officia deserunt mollit anim



Demand response

We help utilities manage the grid and shave the peaks caused by higher renewable energy generation or peaks in electricity demand. People and business do not need to buy more expensive energy during the peaks and in the meanwhile utilities save money from additional infrastructure and power investments.



Customers' behavior tracking

We provide utilities with behind the meter data which they can use for customers' behaviour analysis in order to understand them better. In this way utilities can create personalized tariff offers as well as tailor-made energy programs and increase their customers' loyalty.



Energy engagement

We assist utilities in their efforts to raise customers' awareness of energy consumption and apply programs for energy savings.



Building energy management

We supply utilities with device solution which helps their customers track energy use and improve energy efficiency.

Home automation solutions give a great opportunity for utilities to escape from the "utility death spiral" and develop new business models.

Value proposition for utility companies

- Cost reduction
- New revenue streams by value added services
- Efficiency
- Quality of service
- Customer satisfaction
- Positive environment impact

Our case studies



German Utility & Energy Management: LoRaWAN® Based Building Solutions

Within 1 month of initial discussions, MClimate and the client started testing a LoRaWAN® based thermostat valve solution for the German market.

Key features of the solution include:

- Custom modes and integration with additional sensors using LoRaWAN®
- No upfront investment for the client
- Short delivery timeframe
- Solution applicable to large municipal and office buildings
- Thousand of units deployed within a limited timeframe due to EU based production



Nordics Telecom Energy Management: Residential Heating Control and monitoring

MClimate successfully delivered a white label product enabling the telco to have their own IoT state-of-art solution without spending years and a lot of money on product development.

Key features of the solution include:

- Low upfront investment with limited risk
- Ongoing EU based product support
- Scalability and short delivery lead time
- Rigorously tested and secure product
- Military-grade wide range radio technology





 **LoRa Alliance** Member



 We
make any
building
smart.
www.mclimate.eu

 **M Climate**

31, Alexander Malinov blvd, Sofia, Bulgaria, Campus X,
Building 2, floor 1, office 1-2, sales@mclimate.eu,
+359 800 3 1010,

<https://mclimate.eu/pages/partners>



Last update 14.03.2024