

# Ultra Low Power Solar LoRaWAN<sup>®</sup> Gateway

**SG50**

User Guide



## Safety Precautions

Milesight will not shoulder responsibility for any loss or damage resulting from not following the instructions of this operating guide.

- ❖ The device must not be disassembled or remodeled in any way.
- ❖ Do not place the device close to objects with naked flames.
- ❖ Do not place the device where the temperature is below/above the operating range.
- ❖ Do not power on the device or connect it to other electrical device when installing.
- ❖ Check lightning and water protection when used outdoors.
- ❖ Do not connect or power the equipment using cables that have been damaged.

## Declaration of Conformity

SG50 is in conformity with the essential requirements and other relevant provisions of the CE, FCC, and RoHS.



**Copyright © 2011-2024 Milesight. All rights reserved.**

All information in this guide is protected by copyright law. Whereby, no organization or individual shall copy or reproduce the whole or part of this user guide by any means without written authorization from Xiamen Milesight IoT Co., Ltd.

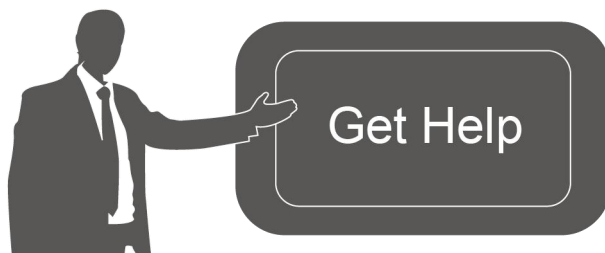

For assistance, please contact

Milesight technical support:

Email: [iot.support@milesight.com](mailto:iot.support@milesight.com)

Support Portal: [support.milesight-iot.com](http://support.milesight-iot.com)

Tel: 86-592-5085280

Fax: 86-592-5023065

Address: Building C09, Software Park  
Phase III, Xiamen 361024,  
China

## Revision History

Date	Doc Version	Description
Oct. 15, 2023	V 1.0	Initial version
Jan. 15, 2024	V 1.1	1. Support to connect to Milesight gateway embedded network server; 2. Support to connect to Milesight Development platform and DeviceHub V2.

# Contents

1. Product Introduction .....	5
1.1 Overview .....	5
1.2 Key Features .....	5
2. Hardware Introduction .....	5
2.1 Packing List .....	5
2.2 Hardware Overview .....	6
2.3 Button and LED Indicator .....	7
2.4 Dimensions (mm) .....	8
3. Hardware Installation .....	8
3.1 SIM Card Installation .....	8
3.2 Power Supply .....	8
3.3 Gateway Installation .....	9
3.3.1 Mounting Bracket Installation .....	9
3.3.2 Solar Panel Installation .....	10
3.3.3 Device Installation .....	10
3.3.4 Antenna Installation .....	11
4. Access the Gateway .....	13
5. Operation Guide .....	14
5.1 Status .....	14
5.2 Packet Forward .....	16
5.2.1 General .....	16
5.2.2 Radios .....	18
5.2.3 Packet Filters .....	20
5.2.4 Advanced .....	21
5.2.5 Traffic .....	22
5.3 Network .....	23
5.3.1 WLAN .....	23
5.3.2 Cellular .....	24
5.4 Service .....	26
5.5 System .....	26
5.5.1 General .....	26
5.5.2 Time .....	27
5.5.3 Access Service .....	28
5.6 Maintenance .....	28
5.6.1 Log .....	28
5.6.2 Backup/Upgrade .....	28
5.6.3 Reboot .....	29
Appendix .....	30
Default Frequency .....	30

# 1. Product Introduction

## 1.1 Overview

SG50 is an energy-efficient solar LoRaWAN® gateway designed for outdoor environments with limited power availability and ample solar energy resources. With built-in batteries and accessorial solar panel, SG50 can work independently in various scenarios, especially the places with hard access to power resources.

Besides the high adaptability, SG50 is highly compatible with mainstream network servers and supports remote management via remote network servers which provides both convenience and secured management.

Benefiting from its robust structural design and high IP67 protection rate, SG50 can work smoothly in harsh environments. It is specifically tailored for applications such as oil and gas, mining, forestry, and remote industries where power consumption must be carefully managed.









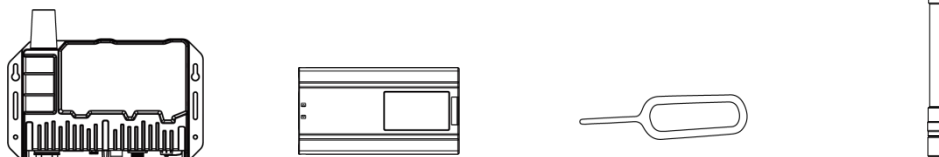

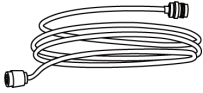
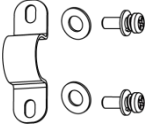
## 1.2 Key Features

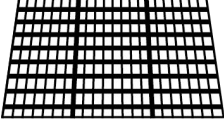
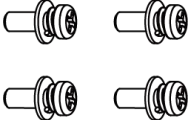
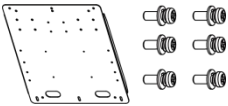
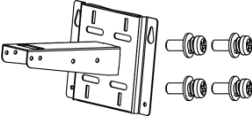
- Fast deployment with the all-in-one design and standard accessories
- Built-in rechargeable batteries & accessorial solar panel for wireless usage
- Support cellular for backhaul network enabling independent networking
- Equipped with high-efficient power management design prolonging its battery life up to 4 days
- IP67 enclosure and robust structural design promote its strength and working lifespan
- Equipped with SX1302 chip, handling a higher amount of traffic with lower consumption
- Equipped with GPS for simple remote management and deployment
- Milesight DeviceHub 2.0 & Development Platform provide easy and centralized management of remote devices
- Compatible with mainstream network servers like The Things Industries, ChirpStack, AWS IoT Core for LoRaWAN®, etc.

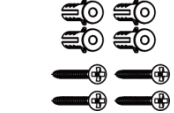
## 2. Hardware Introduction

### 2.1 Packing List

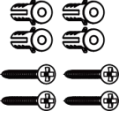

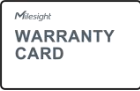
1 × SG50 Device	1 × Battery Pack	1 × SIM Card Ejector Tool	1 × LoRaWAN® Antenna
			
1 × Antenna Coaxial Cable	1 × Antenna U-strap Kit	1 × Antenna U-bolt Kit	1 × Solar Panel (with M12 Power Cable)
			
4 × Mounting Screws	1 × Solar Panel Bracket Kit	1 × Mounting Bracket Kit	2 × Hose Clamps
			
4 × Wall Mount Screw Kits	1 × Quick Guide	1 × Warranty Card	
			

**!** If any of the above items is missing or damaged, please contact your sales representative.

## 2.2 Hardware Overview

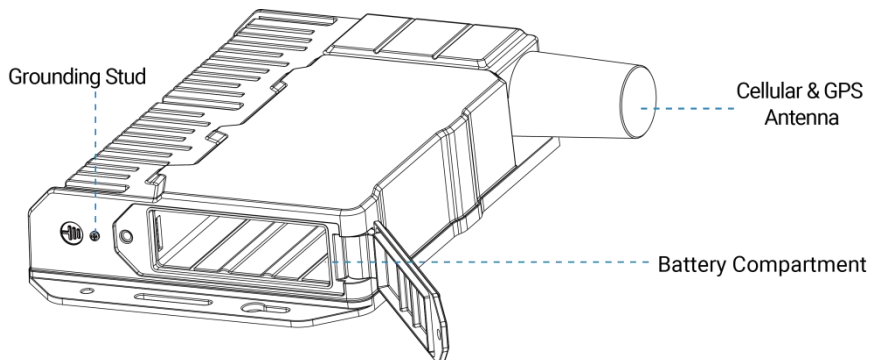

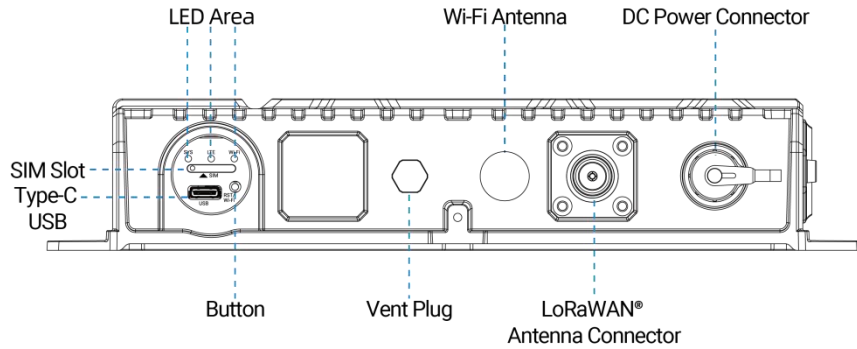

## 2.3 Button and LED Indicator

### LED Indicators

LED	Indication	Status	Description
SYS	Power & System Status	Off	The power is off
		Green Light	The system is running properly
		Red Light	The system goes wrong
LTE	Cellular Status	Off	SIM card is registering or failed to register (or there are no SIM cards inserted)
		Green Light	Blinking slowly: SIM card has been registered and is ready for dial-up
			Blinking rapidly: SIM card has been registered and is dialing up now
			Static: SIM card has been registered and dialed up successfully
Wi-Fi	Wi-Fi Status	Off	Wi-Fi is off
		Green Light	Blinking slowly: Wi-Fi is starting
			Static: Wi-Fi is on

### Wi-Fi/Reset Button

Function	Action	LED Indication
Turn On Wi-Fi	When Wi-Fi is disabled, quickly press the button once to turn on Wi-Fi for 10 minutes.	Wi-Fi: Off → On
Turn Off Wi-Fi	When Wi-Fi is enabled, quickly press the button once to turn off Wi-Fi for 10 minutes.	Wi-Fi: On → Off
Reset to Factory Default	Press and hold the button for more than 5 seconds	SYS: blinks rapidly.

## 2.4 Dimensions (mm)

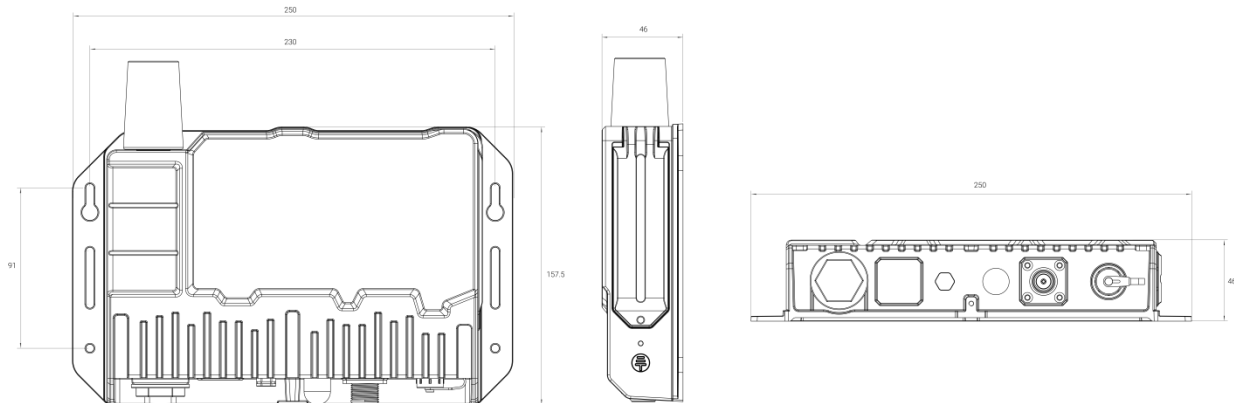

## 3. Hardware Installation

### 3.1 SIM Card Installation

1. Take the SIM cover down, and use an ejector tool to open the SIM card tray. Insert the nano (4FF) SIM card, then put the slot with the SIM card back into the device.
2. Rotate back the cover and tighten it with a wrench to prevent water from entering the device.

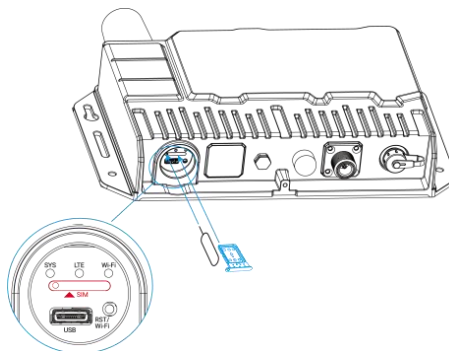

### 3.2 Power Supply

SG50 can be powered by either a 12-24 VDC external supply or a solar panel. In the meantime, the internal battery pack will also be charged. When the external supply is disconnected or there is not enough power for the solar panel, SG50 can be powered by the internal battery pack.

### Battery Installation

1. Release the fixing screw on the side of the device, and remove the battery compartment cover.
2. Push the battery into the battery compartment as the icon shows. If you need to take out the battery, hold on the latches on the battery to pull it out.
3. Fix the cover back to the device using the fixing screw.

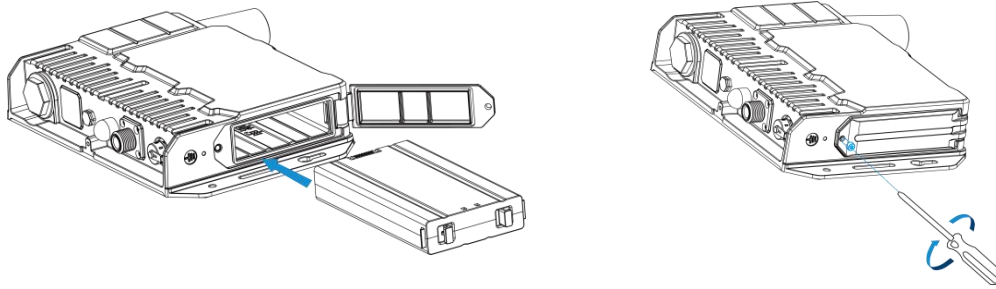
**Note:**

- After installing the battery, the device will not power on automatically. Please connect the power cable of the solar panel to the device to turn it on. When the power cable is disconnected, the device will power off.
- The device can not be charged when its temperature is more than 50°C. Please avoid direct exposure of the device to sunlight.
- When the device detects the temperature is lower than 0°C and solar panel power is enough (more than 7W), the device will heat the battery until the temperature reaches to 10°C, then charge the battery if the battery level is not full.
- The battery should be removed from the device if it will not be used for an extended period.

### 3.3 Gateway Installation

SG50 with solar panel can be mounted either to a wall or pole. It is suggested to install the device on sunny days for solar panel adjustment and charging.

#### 3.3.1 Mounting Bracket Installation

**Wall Mounting:**

Drill 4 holes on the wall according to the mounting bracket and insert the wall plugs into these holes. Then fix the mounting bracket to the wall by fixing the wall mounting screws into the wall plugs.

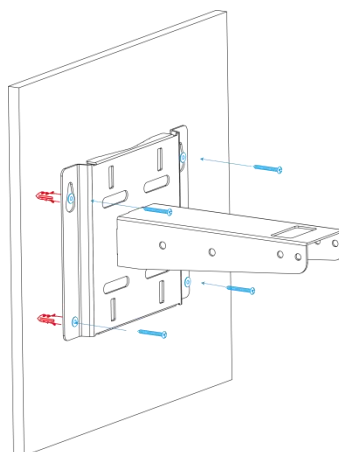
**Pole Mounting:**

Straighten the hose clamps and slide them through the rectangular rings in the mounting bracket. Wrap the hose clamps around the pole, then use a screwdriver to tighten the locking mechanism by turning it clockwise.

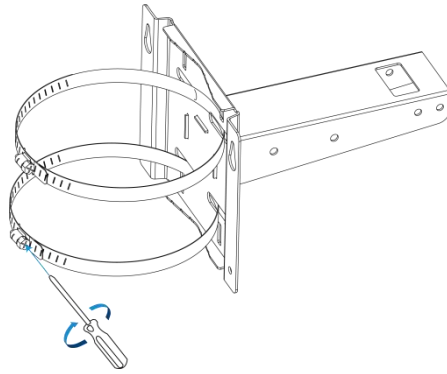

### 3.3.2 Solar Panel Installation

1. Fix the solar panel to the solar panel bracket using 6 fixing screws.

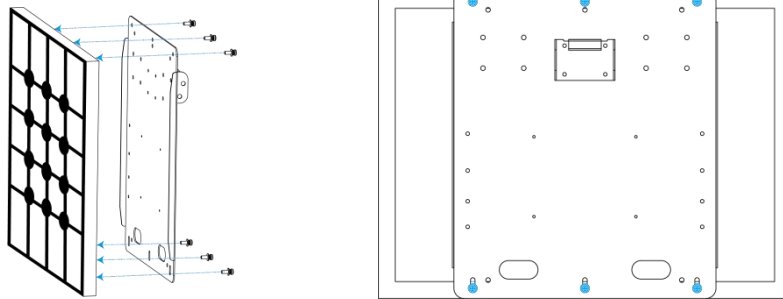

2. Hang the solar panel bracket onto the mounting bracket and fix both parts using 2 fixing screws first. Adjust the angle of the solar panel bracket (15°, 45°, and 75° is optional) based on the installation environment. Then fix the remaining two screws to the solar panel bracket.

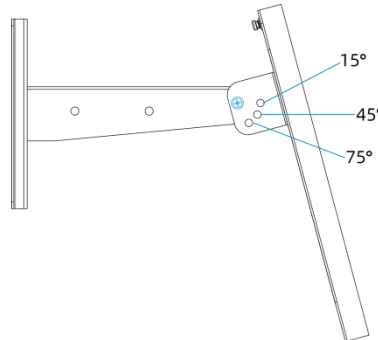

### 3.3.3 Device Installation

1. Fix the device to the opposite side of the solar panel bracket using 4 screws. When installation, it is suggested to fix the 2 screws on the top at first.

2. Install antennas as [Antenna Installation](#) chapter.

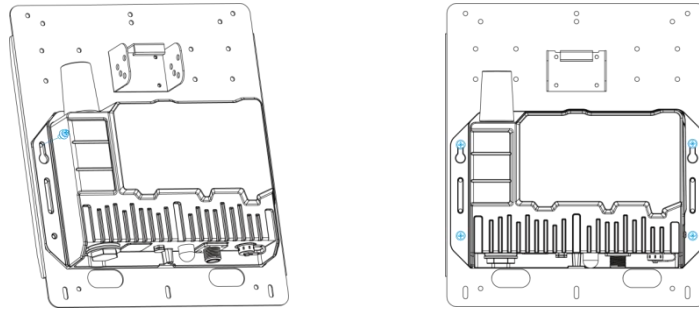

3. Connect M12 power cable of the solar panel to DC power connector of the device, then the device will power on automatically.

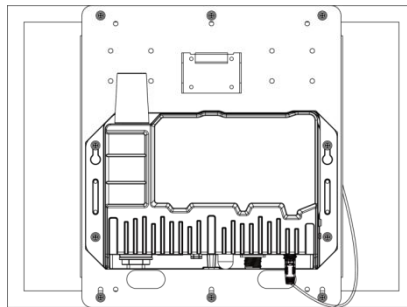

### 3.3.4 Antenna Installation

#### U-strap Mounting:

1. Pass the LoRaWAN® antenna through the U-strap clamp and fix the U-strap clamp to the side of the mounting bracket using 2 flat washers and 2 screws.

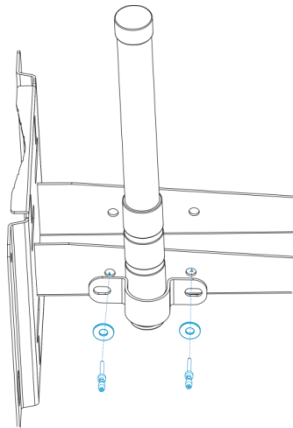

2. Connect one end of the antenna coaxial cable to the LoRaWAN® antenna, the opposite end to the device's antenna connector.

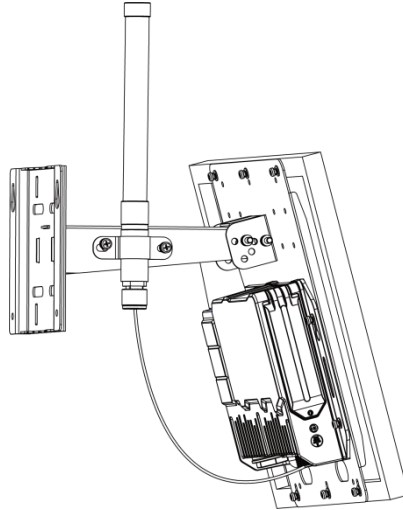

### U-bolt Mounting:

1. Pass the LoRaWAN® antenna through the antenna clamp and fix it using 4 screws, then wrap the U-bolt around the pole and fix the clamp with nuts and other accessories.

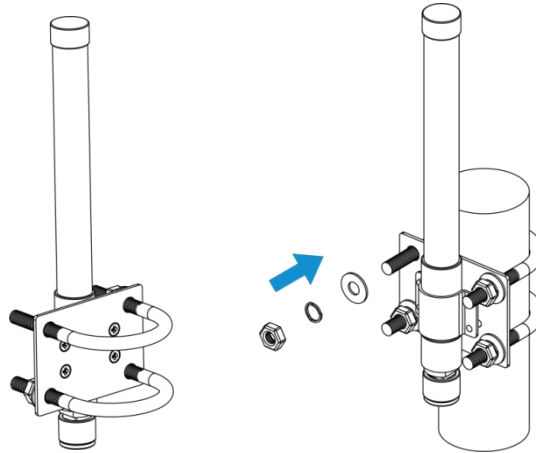

2. Connect one end of the antenna coaxial cable to the LoRaWAN® antenna, the opposite end to the device's antenna connector.

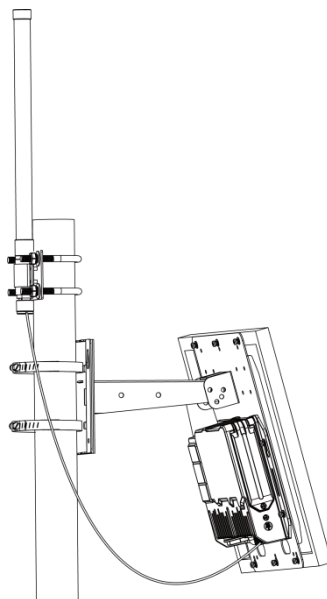

## 4. Access the Gateway

G50 provides user-friendly web GUI for configuration and users can get access to it via Wi-Fi connection. The default settings are listed below:

Wi-Fi SSID: **Gateway\_XXXXXX** (can be found on the label)

Wi-Fi IP Address: **192.168.23.1**

Browser: **Chrome (Recommended)**

Username: **admin**

Password: **password**

Configuration Steps:

Step 1: Connect M12 power cable to the device to turn on the device and ensure the Wi-Fi LED is statically on.

Step 2: Enable the Wireless Network Connection on your computer and search for the corresponding access point, then connect the computer to this access point.

Step 3: Open the browser and type 192.168.23.1 to access the web GUI.

Step 4: Select the language.

Step 5: Enter the default username and password to log in the web GUI.

English



Step 6: It is suggested to follow the wizard to complete basic settings. Users can also skip all steps or exit the wizard to configure the device.

1) Configure the cellular settings to set up cellular connections. Usually, it is necessary to type the APN parameter to register to cellular networks. For details please refer to [Cellular](#) chapter.

2) Configure correct system time. For details please refer to [Time](#) chapter.

3) Configure the device to connect a LoRaWAN® network server. For details please refer to [Packet Forward-General](#) chapter.

4) Configure the packet filter. For details please refer to [Packet Forward-Packet Filters](#) chapter.

5) Configure the WLAN settings. For details please refer to [WLAN](#) chapter.

## 5. Operation Guide

### 5.1 Status

The screenshot displays the 'Cellular' status page for a Milesight gateway (SG50-L09NA-868M). It includes sections for Battery Level (84% Charging), Battery Temperature (27°C), System Information (Firmware, Hardware, Region, Local Time, Uptime, CPU Temperature, Solar Status), GPS (Longitude, Latitude, Altitude), WLAN (Enabled, SSID: Gateway\_F7FC26), LoRaWAN Packet Forward (Connected, Server Type: ChirpStack-Generic, Server Address: 112.124.8.125), and Cellular (Connected, IP Address: 10.139.25.142, Connection Duration: 0days, 00:05:50).

#### Overview

Parameters	Description
Model	The whole model name of the gateway.
SN	The serial number of the gateway.
EUI	The unique identifier of the gateway and it's non-editable.
Battery Level & Status	The internal battery level and current charging status.
Battery Temperature	The temperature of the internal battery.

#### System Information

Firmware Version	The currentl firmware version of the gateway.
Hardware Version	The current hardware version of the gateway.
Region	The LoRaWAN® frequency region of the gateway. This is non-editable. <b>Note:</b> the frequency plan can be changed on <b>Packet Forward &gt; Radios</b> page and will be not affected by this region value. For example, the gateway with region AU915 can also change the frequency plan to US915, AS923-1, etc.
Local Time	The current local time of the system.
Uptime	The information on how long the gateway has been running.
CPU Temperature	The temperature of CPU.
Solar Status	The current solar powering status.

#### GPS

Longitude	The latitude of the location.
Latitude	The longitude of the location.
Altitude	The altitude of the location.
<b>WLAN</b>	
SSID	The SSID of the WLAN access point.
<b>LoRaWAN Packet Forward</b>	
Server Type	The LoRaWAN® packet forward connection type.
Server Address	The LoRaWAN® network server address. When server type is Basic Station, this will show LNS URI and CUPS URI.
<b>Cellular</b>	
IP Address	The IP address of cellular network.
Connection Duration	The information on how long the cellular network has been connected.

<b>Cellular</b>	
Parameters	Description
<b>Modem</b>	
SIM Status	<p>Corresponding detection status of module and SIM card.</p> <ul style="list-style-type: none"> <li>● No SIM Card: the SIM card is not inserted</li> <li>● SIM Card Error: the SIM card is error</li> <li>● PIN Error: the PIN code is error</li> <li>● PIN Required: the SIM card requires to type PIN code</li> <li>● PUK Required: the SIM card requires to be unlocked by PUK code</li> <li>● No Signal: no cellular signal</li> </ul>

	<ul style="list-style-type: none"> <li>● Ready: the SIM card is inserted</li> <li>● Down: the SIM card is deactivated</li> </ul>
Register Status	The registration status of SIM card.
Model	The name of cellular module.
Version	The firmware version of cellular module.
Signal Level	The RSSI (Received Signal Indicator) of registered cellular network.
IMEI	The IMEI of the cellular module.
IMSI	The IMSI of the SIM card.
ICCID	The ICCID of the SIM card.
ISP	The network provider on which the SIM card registers.
Network Type	The connected network type, such as FDD LTE.
PLMN ID	The current PLMN ID, including MCC, MNC, LAC and Cell ID.
LAC	The location area code of the SIM card.
Cell ID	The Cell ID of the SIM card location.

## Network

Connection Status	The connection status of the cellular network.
Connection Duration	The information on how long the cellular network has been connected.
IPv4 Address	The IPv4 address of the cellular network.
IPv4 Gateway	The IPv4 gateway of the cellular network.
IPv4 DNS	The IPv4 DNS sever of the cellular network.

## 5.2 Packet Forward

SG50 supports to work as a packet forwarder to set up communication between LoRaWAN® end devices and LoRaWAN® network server.

### 5.2.1 General

General	Radios	Packet Filters	Advanced	Traffic
EUI	24E124FFFEF7FC26			
Gateway ID *	<input type="text" value="24E124FFFEF7FC26"/>			
Destination				
Enable	<input checked="" type="checkbox"/>			
Type	<input type="text" value="Semtech"/>			Connected
Server Address	<input type="text" value="eu1.cloud.thethings.network"/>			
Port Up	<input type="text" value="1700"/>			
Port Down	<input type="text" value="1700"/>			

## General

Parameters	Description
EUI	The unique identifier of the gateway and it's non-editable.
Gateway ID	The customizable ID for registering gateway to network server, such as TTN. It is the same as gateway EUI by default.

## Destination

Enable	Enable or disable the packet forward feature.
Type	<p>Select packet forward type among Semtech, Chirpstack-Generic or Basic Station, Remote Embedded NS, DeviceHub LNS or Milesight Development Platform LNS.</p> <p><b>Semtech:</b> connect to network server through the Semtech UDP protocol. It supports to connect to most mainstream network servers.</p> <p><b>Chirpstack-Generic:</b> connect to Chirpstack via generic MQTTgateway bridge.</p> <p><b>Basic Station:</b> connect to network server through TCP protocol. When configuring, there is no need to configure both LNS and CUPS settings.</p> <p><b>Remote Embedded NS:</b> connect to embedded network server of Milesight UG65/UG67/UG56 gateways.</p> <p><b>DeviceHub LNS:</b> connect to Milesight DeviceHub LNS. This needs to select and enable DeviceHub 2.0 option on <b>Service</b> page and type the platform address.</p> <p><b>Milesight Development Platform LNS:</b> connect to Milesight Development Platform LNS. This needs to select and enable Milesight Development Platform option on <b>Service</b> page and add the gateway to your platform account.</p>

<b>Semtech</b>	
Server Address	The LoRaWAN® network server IP address or domain.
Port Up	The UDP port to forward uplinks from end device to network server.
Port Down	The UDP port to forward downlinks from network server to end device.
<b>Basic Station</b>	
URI	The URL of LoRaWAN® network server. Please type as below format and replace <i>&lt;server-address&gt;</i> and <i>&lt;port&gt;</i> as real server address and server port. <b>LNS URI:</b> <i>wss://&lt;server-address&gt;:&lt;port&gt;</i> or <i>ws://&lt;server-address&gt;:&lt;port&gt;</i> <b>CUPS URI:</b> <i>https://&lt;server-address&gt;:&lt;port&gt;</i>
CA File	CA certificate to secure the server domain. <b>Note:</b> change the certificate file format as <i>.trust</i> before import.
Client Certificate File	Client certificate file to verify the identity of the gateway.
Client Key File	Private key file to verify the identity of the gateway.
GPS	When connecting via LNS, enable or disable it to forward gateway GPS data to network server.
<b>Chipstack-Generic</b>	
Server Address	The LoRaWAN® network server IP address or domain.
MQTT Port	The LoRaWAN® network server port.
User Credentials	After enabled, username and password are required to type for verification.
TLS Authentication	Select from "Self signed certificates" or "CA signed server certificate". <b>CA signed server certificate:</b> verify with the certificate issued by Certificate Authority (CA) that pre-loaded on the device. <b>Self signed certificates:</b> upload the custom CA certificates, client certificates and secret key for verification.
<b>Remote Embedded NS</b>	
Server Address	The IP address or domain name of Milesight controller gateway.
MQTT Port	The communication port to Milesight controller gateway.

## 5.2.2 Radios

General **Radios** Packet Filters Advanced Traffic

**Radio Channel Setting**

Supported Freq: EU868

Radio 0: 867.5

Radio 1: 868.5

**Multi Channels Setting**

Enable	Radio	Frequency/MHz
<input checked="" type="checkbox"/>	Radio 1	868.1
<input checked="" type="checkbox"/>	Radio 1	868.3
<input checked="" type="checkbox"/>	Radio 1	868.5
<input checked="" type="checkbox"/>	Radio 0	867.1
<input checked="" type="checkbox"/>	Radio 0	867.3
<input checked="" type="checkbox"/>	Radio 0	867.5
<input checked="" type="checkbox"/>	Radio 0	867.7
<input checked="" type="checkbox"/>	Radio 0	867.9

**LoRa Channel Setting**

Enable:

Radio: Radio 1

Frequency/MHz: 868.3

Bandwidth/kHz: 250KHz

Data Rate/Bit: SF7

**FSK Channel Setting**

Enable:

Radio: Radio 1

Frequency/MHz: 868.8

Bandwidth/kHz: 125KHz

Data Rate/Bit: 50000

Radios	
Parameters	Description
Radio Channel Setting	

Supported Freq	The LoRaWAN® frequency plan used for the uplink and downlink frequencies and datarates. Available options depend on the gateway's model: <b>-470M:</b> CN470 <b>-868M:</b> EU868, RU864, IN865 <b>-915M:</b> US915, AU915, KR920, AS923-1&2&3&4
Radio 0/Radio 1	The center frequencies to receive packets from LoRaWAN® nodes.
<b>Multi Channels Setting</b>	
Enable	Enable or disable this channel to transmit packets.
Radio	Choose Radio 0 or Radio 1 as the center frequency.
Frequency/MHz	Set the frequency of this channel. Range: center frequency $\pm$ 0.4625.
<b>LoRa/FSK Channel Setting</b>	
Enable	Enable or disable this channel to transmit packets.
Radio	Choose Radio 0 or Radio 1 as the center frequency.
Frequency/MHz	Set the frequency of this channel.
Bandwidth/kHz	Set the bandwidth of this channel.
Data Rate/Bit	Set the data rate.

### 5.2.3 Packet Filters

SG50 supports to filter uplink packets via different conditions to reduce network congestion, save network traffic and ensure the safe operations.

General
Radios
Packet Filters
Advanced
Traffic

Filters by NetID ⓘ

Mode  White List  Black List

List  +

Filters by JoinEUI ⓘ

Mode  White List  Black List

List  To  +

Filters by DevEUI ⓘ

Mode  White List  Black List

List  To  +

Packet Filters	
Parameters	Description
Filters by NetID	Forward/Not forward the uplink packets that meet the NetID.
Filters by JoinEUI	Forward/Not forward the join request packets that meet the JoinEUI range.
Filters by DevEUI	Forward/Not forward the join request packets that meet the DevEUI range.
Mode	Select the filter mode as black list or white list. <b>White List:</b> Only forward the packets in this list to the network server. <b>Black List:</b> Only forward the packets except this list to the network server.
List	Set the specific filtering value or range list. Every condition supports to add 5 lists at most.

**Note:** When join EUI and dev EUI are both configured, only packets that meet both conditions will be forwarded.

## 5.2.4 Advanced

Advanced	
Parameters	Description
<b>Beacon Setting</b>	
Beacon Period	Interval of gateway sending beacons for Class B device time synchronization. 0 means the gateway will not send beacons. <b>Please select the value as 128 if end device type is Class B.</b>
<b>Intervals Setting</b>	
Keep Alive Interval/s	The interval of keepalive packet which is sent from gateway to network server to keep the connection stable and alive.

Start Interval/s	The interval to update the network server with gateway statistics.
Push Timeout/ms	The timeout to wait for the response from server after the gateway sends data.
<b>LBT Setting</b>	
Enable	Enable or disable LBT feature. Listen before talk (LBT) is used to detect whether the downlink channel is idle and avoid channel access conflicts. <b>Note: AU915 and US915 do not support LBT feature.</b>
RSSI Target	The criteria of an idle channel. If actual RSSI of a channel is less than the criteria/target, the channel is considered as idle.
<b>Expert Options</b>	
Enable	After enabled, the device supports customizing the configuration file to configure packet forwarder and <b>customized configuration will overwrite the packet forward configurations of web GUI.</b> To customize configuration file with correct format, click "Example" to go to reference page.

## 5.2.5 Traffic

SG50 supports to display latest 30 pieces of traffic received from end devices or network server.

Direction	Time	Frequency	Datarate	Channel	RSSI	SNR	Data
Up	0000-00-00T00:00:00.000000Z	868.300000	SF12BW125	1	-68	7.8	gHYKGAcbxpv1CCs4WQqdzDHiEnqTV8=
Up	0000-00-00T00:00:00.000000Z	868.300000	SF10BW125	1	-59	12.0	AAEAKgDAJJOEMgU4TGEK4SQqSntbxf=
Up	0000-00-00T00:00:00.000000Z	868.300000	SF12BW125	1	-84	-0.5	QFUDAASBYQMNvXWJ55sO6dOGHnbc=
Up	0000-00-00T00:00:00.000000Z	868.100000	SF12BW125	0	-70	8.2	AAABAAAAQUcUjVHQBxBQkMKcHR2Fk=
Up	0000-00-00T00:00:00.000000Z	868.100000	SF10BW125	0	-67	11.5	QCrgK2YAn91a1X42GOkIKRAsbWVRhji=
Up	0000-00-00T00:00:00.000000Z	868.100000	SF10BW125	0	-68	12.2	QCCSkzeA9cVXXBhchcyE2r1L7AW/EKjRvBaSGTbYwWyroZHInjkJqJgV3XGQozWMusHNvZzh49uE=
Up	0000-00-00T00:00:00.000000Z	867.700000	SF7BW125	6	-94	-2.5	QPR6oQCAm1Fv65XGJxO1Ixz7f9Ncuw==
Up	0000-00-00T00:00:00.000000Z	868.500000	SF10BW125	2	-59	8.5	AAEAKgDAJJOEMgU4TGEK4SSzLNDZAls=
Up	0000-00-00T00:00:00.000000Z	868.300000	SF12BW125	1	-95	-6.8	QFFVdlMKBmqvNVdJOJjWYrL2w94tKE/E9U63A9A==
Up	0000-00-00T00:00:00.000000Z	867.700000	SF7BW125	6	-80	10.2	QG1jBQGADY1Vn8n0IEo3KU RCne+nKkG+KJD
Up	0000-00-00T00:00:00.000000Z	868.100000	SF7BW125	0	-80	11.2	QAlyYQeA8AQKklbn7v9pcTRku6ScyZhnVUBe
Up	0000-00-00T00:00:00.000000Z	868.300000	SF7BW125	1	-83	12.0	QG1jBQGADY1Vn8n0IEo3KU RCne+nKkG+KJD

Traffic	
Parameters	Description
Fresh/Stop	<b>Fresh:</b> click to fresh this page to update latest data automatically. <b>Stop:</b> click to stop fresh this page to update latest data.
Direction	The transmission direction of this packet.
Time	The receiving time of this packet.

Frequency	The frequency of receiving or sending this packet.
Datarate	The datarate of this packet.
Channel	The frequency channel of receiving or sending this packet.
RSSI	The received signal strength of this packet.
SNR	The signal-to-noise ratio of this packet.
Data	The encrypted data of this packet.

## 5.3 Network

### 5.3.1 WLAN

SG50 supports wlan feature to work as AP mode to configure device and it can not connect to other access points.

**Note:** one SG50 device only supports 2 devices' WLAN connection to login this device at the same time.

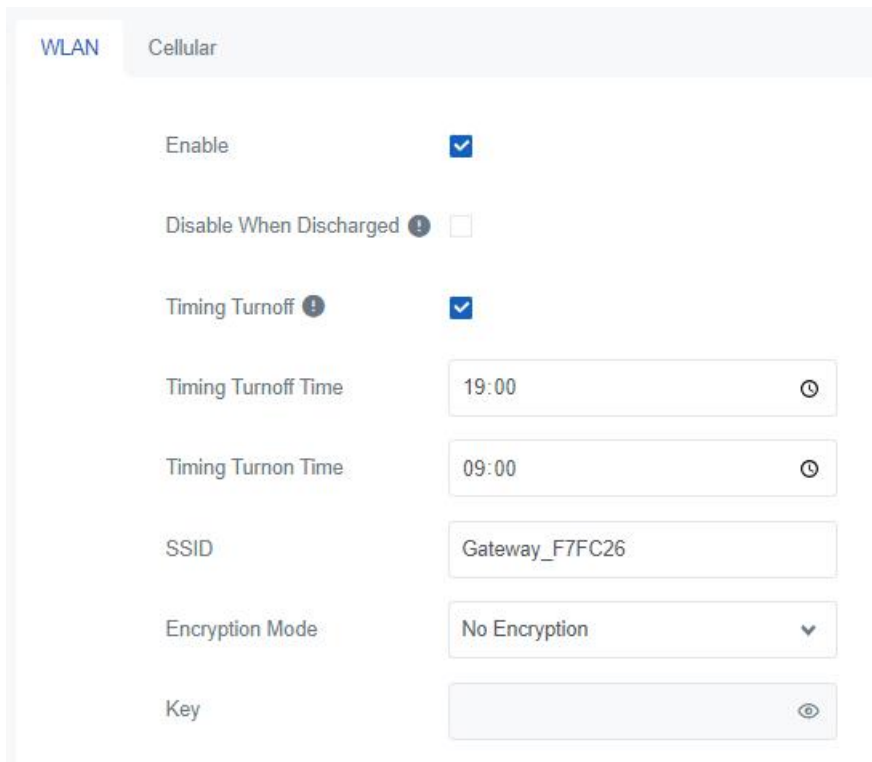

WLAN	
Parameters	Description
Enable	Enable or disable Wi-Fi feature.
Disable When Discharged	After enabled, the device will turn off the Wi-Fi when the battery is discharging to save power.
Timing Turnoff	If this option is enabled, the device will turn off and turn on the Wi-Fi at preset time points of a day.
SSID	The unique name for this device Wi-Fi access point. The default SSID is

	Gateway_XXXXXX. (XXXXXX=last 6 digits of MAC address)
Encryption Mode	No Encryption and WPA-PSK are optional.
Key	Customize the Wi-Fi password when security mode is WPA-PSK.

### 5.3.2 Cellular

SG50 supports to insert a SIM card to get cellular network connections.

WLAN Cellular

  

APN

Username

Password  

Authentication Type  

PIN Code  

AT Command

```
+CGREG: 0,1
OK
```

## | Ping Detection

Enable ⓘ	<input checked="" type="checkbox"/>
Primary Server (IPv4)	<input type="text" value="8.8.8.8"/>
Secondary Server (IPv4)	<input type="text" value="23.5.5.5"/>
Interval/s	<input type="text" value="300"/>
Retry Interval/s	<input type="text" value="5"/>
Timeout/s	<input type="text" value="3"/>
Max Ping Retries	<input type="text" value="3"/>

## Cellular

Parameters	Description
APN	The Access Point Name for cellular dial-up connection provided by local ISP. Please contact cellular operator or search for the Internet to get it.
Username	The username for cellular dial-up connection provided by local ISP.
Password	The password for cellular dial-up connection provided by local ISP.
Authentication Type	Select from None, PAP and CHAP.
PIN Code	A 4-8 characters PIN code to unlock the SIM.
AT Command	Send AT Command to get cellular information or configure advanced settings.
Emergency Reboot	Enable to reboot the device if cellular connection is not available.

## Ping Detection

Enable	After enabled, the device will send ICMP packets to corresponding servers to detect the connection periodically. <b>Note:</b> it is suggested to disable this option if the device is connected to the private network (Non-internet).
Primary Server (IPv4)	The device will send ICMP packet to this server address or hostname to determine whether the Internet connection is still available or not.
Secondary Server (IPv4)	The device will try to ping the secondary server name if primary server is not available.
Interval/s	Time interval between two Pings.
Retry Interval/s	When ping failed, the device will ping again at every retry interval.
Timeout/s	The maximum time which the device will wait for a response to a ping request. If it does not receive a response for the timeout, the ping request will

	be considered to have failed.
Max Ping Retries	The number of times the device will retry sending a ping request until determining that the connection has failed.

## 5.4 Service

**Device Management**

**Auto Provision**

Enable

**Management Platform**

Enable

Platform Type

Devicehub Address

Parameters	Description
Auto Provision	Enable to receive the configurations from Milesight Development Platform once after the device is connected to Internet. This will work even management platform mode is disabled.
<b>Management Platform</b>	
Enable	Enable the device to be managed by Milesight management platforms.
Platform	Milesight DeviceHub 2.0 or Milesight Development Platform is optional.
DeviceHub Address	Set the DeviceHub server IP address or domain name.

## 5.5 System

### 5.5.1 General

General Time

Username

Old Password

New Password

Confirm New Password

Parameters	Description
Username	Enter a new username. Only capital, lowercase, digits, "_", and "-" are allowed.
Old Password	Enter the old password.
New Password	Enter a new password.
Confirm New Password	Enter the new password again.

## 5.5.2 Time

General Time

Current Time 2023-10-25 13:47:15

Time Zone

Sync Type

NTP Server Address

Parameters	Description
Current Time	Show the current system time.
Time Zone	Click the drop-down list to select the time zone you are in.
Sync Type	It's fixed as Sync with NTP Server.
NTP Server Address	Set the NTP Server's IP address or domain name.

## 5.5.3 Access Service

HTTP

Local access

Access port

Parameters	Description
Local access	Enable or disable the local access of HTTP.
Access port	Set the service port of HTTP.

## 5.6 Maintenance

### 5.6.1 Log

Log Backup/Upgrade Reboot

Log Severity

Log File

Core dump

Parameters	Description
Log Severity	The list of severities follows the syslog protocol.
Log File	Download log file.
Core dump	Core dump file contains a snapshot of a program's memory at a specific point in time when the program encounters a critical error or crashes, which can be used for debugging and troubleshooting purposes.

### 5.6.2 Backup/Upgrade

Log Backup/Upgrade Reboot

Backup

Download Backup

Restore

Reset

Config File

Upgrade

Firmware Version 50.0.0.1

Reset

Upgrade Firmware

Backup/Upgrade	
Parameters	Description
<b>Backup</b>	
Backup	Export the current configuration file to the PC.
<b>Restore</b>	
Reset	Reset device to factory default settings. The device will restart after reset process is done.
Config File	Click "Import" button to select configuration file, and then click "Restore" button to upload the configuration file to the device.
<b>Upgrade</b>	
Firmware Version	Show the current firmware version.
Reset	When this option is enabled, the device will be reset to factory defaults after upgrade.
Upgrade Firmware	Click "Import" button to select the new firmware file, and click "Upgrade" to upgrade firmware. <b>Note:</b> 1) Ensure that the distance between the computer and the SG50 device is not too far during the upgrade; otherwise, the upgrade process may fail. 2) After upgrade, the device will restart automatically. Please reconnect Wi-Fi to access the web GUI.

### 5.6.3 Reboot

On this page you can reboot the gateway and return to the login page. We strongly recommend

clicking "Save" button before rebooting the gateway so as to avoid losing the new configuration.

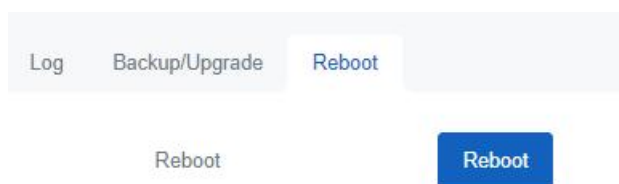

## Appendix

### Default Frequency

Supported Freq	Channel/MHz
CN470	471.9, 472.1, 472.3, 472.5, 472.7, 472.9, 473.1, 473.3 (8~15)
EU868	868.1, 868.3, 868.5, 867.1, 867.3, 867.5, 867.7, 867.9
IN865	865.0625, 865.4025, 865.6025, 865.985, 866.185, 866.385, 866.585, 866.785
RU864	868.9, 869.1, 869.3, 867.3, 867.5, 867.7, 867.9, 868.1
AU915	916.8, 917, 917.2, 917.4, 917.6, 917.8, 918, 918.2 (8~15)
US915	903.9, 904.1, 904.3, 904.5, 904.7, 904.9, 905.1, 905.3 (8~15)
KR920	922.1, 922.3, 922.5, 922.7, 922.9, 923.1, 923.3, 923.5
AS923-1	923.2, 923.4, 922, 922.2, 922.4, 922.6, 922.8, 923
AS923-2	921.2, 921.4, 921.6, 921.8, 922, 922.2, 922.4, 922.6
AS923-3	916.6, 916.8, 917, 917.3, 917.4, 917.6, 917.8, 918
AS923-4	917.3, 917.5, 917.7, 917.9, 918.1, 918.3, 918.5, 918.7

-END-