

IR Breakbeam People Counter

Featuring LoRaWAN®

VS360

User Guide



Safety Precautions

Milesight will not hold responsibility for any loss or damage resulting from not following the instructions of this operating guide.

- ❖ The device must not be disassembled or remodeled in any way.
- ❖ To ensure the security of your device, please change the device password during the initial configuration. The default password is 123456.
- ❖ The device is not intended to be used as a reference sensor, and Milesight will not hold responsibility for any damage which may result from inaccurate readings.
- ❖ Do not place the device in places where the temperature is below/above the operating range.
- ❖ Do not place the device near naked flames, heat source (such as oven), or expose it to direct sunlight, cold source, liquid, and with extreme temperature changes.
- ❖ Remove the battery from the device if it is not to be used for an extended period. Otherwise, the battery might leak and damage the device.
- ❖ The device must never be subjected to shocks or impacts.

Declaration of Conformity

VS360 is in conformity with the essential requirements and other relevant provisions of the CE, FCC, and RoHS.

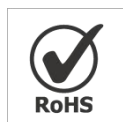
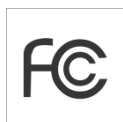

Copyright © 2011-2024 Milesight. All rights reserved.

All information in this guide is protected by copyright law. Whereby, no organization or individual shall copy or reproduce the entire or part of this user guide by any means without written authorization from Xiamen Milesight IoT Co., Ltd.

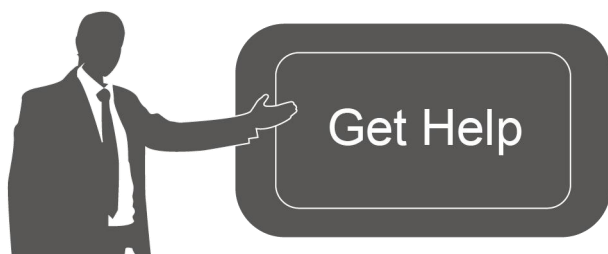

For assistance, please contact

Milesight technical support:

Email: iot.support@milesight.com

Support Portal: support.milesight-iot.com

Tel: 86-592-5085280

Fax: 86-592-5023065

Address: Building C09, Software Park
Phase III, Xiamen 361024,
China

Revision History

Date	Doc Version	Description
Aug. 16, 2024	V 1.0	Initial version

Contents

1. Product Introduction	5
1.1 Overview	5
1.2 Key Features	5
2. Hardware Introduction	5
2.1 Packing List	5
2.2 Hardware Overview	6
Master Device:	6
Node Device:	6
2.3 Button Description	6
Master Device	6
Node Device	7
2.4 Dimensions (mm)	7
3. Power Supply	7
4. Operation Guide	8
4.1 NFC Configuration	8
4.2 LoRaWAN® Settings	9
4.3 General Settings	11
4.4 Advanced Settings	12
4.4.1 Threshold Settings	12
4.4.2 Data Storage	13
4.4.3 Data Retransmission	14
4.4.4 Milesight D2D Settings	15
4.5 Maintenance	17
4.5.1 Backup	17
4.5.2 Upgrade	17
4.5.3 Reset to Factory Default	18
5. Installation Instruction	19
5.1 Installation	19
5.2 Uninstallation	21
5.3 Factors Affecting Accuracy	21
6. Device Payload	21
6.1 Basic Information	21
6.2 Sensor Data	22
6.3 Downlink Commands	23
6.4 Historical Data Enquiry	27

1. Product Introduction

1.1 Overview

The VS360 is a people counting sensor that is based on IR Breakbeam technology. Equipped with two devices, the principle is that the target blocks the infrared beam by detecting the area to achieve the purpose of counting, so it is not affected by the ambient temperature and the color of the target clothes, and it has strong adaptability. Adjusting the current of the node device reduces the power consumption and extends the battery life. As a Milesight D2D controller, the VS360 seamlessly communicates with other Milesight D2D agent devices, establishing more possible connections and paving the way for smoother operations.

With easy configuration and wireless detection, the VS360 facilitates simple deployment and connectivity. Compliant with the Milesight LoRaWAN[®] gateway and Milesight Development Platform, users can know the number of passage people and trigger other sensors or appliances easily.

1.2 Key Features

- Provide good accuracy rate for bi-directional people counting without sunlight interference
- Based on IR Breakbeam technology which is not affected by ambient temperature with more adaptability
- Ultra-low power consumption with up to 3-year battery life without replacement
- Wireless connectivity and convenient size improve the accessibility and simplicity of deployment
- Visual data about people counting via screen
- Smart scheduled hibernate mode to save battery power
- Support Milesight D2D protocol to enable ultra-low latency and directly control without gateways
- Equipped with NFC for one touch configuration and support card emulation mode
- Function well with standard LoRaWAN[®] gateways and network servers
- Compatible with the Milesight Development Platform

2. Hardware Introduction

2.1 Packing List

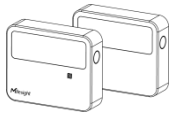

1 ×
VS360 Sensor



2 ×
Back Covers



4 × ER14505
Li-SoCl₂ Batteries



4 × Wall Screw
Mount Kits

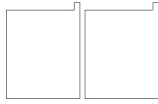

2 × 3M Double-sided
Tapes



1 ×
Quick Start Guide



1 ×
Warranty Card

! If any of the above items are missing or damaged, please contact your sales representative.

2.2 Hardware Overview

Master Device:

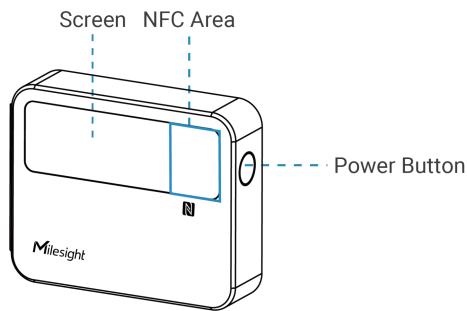

Battery Compartment Reset Button

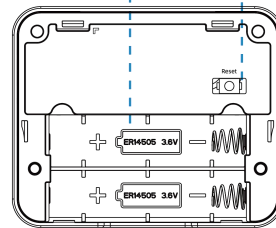

Node Device:

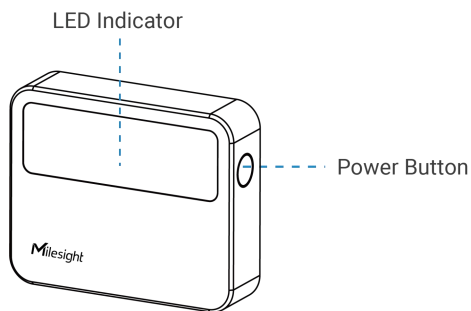

Battery Compartment DIP Switch

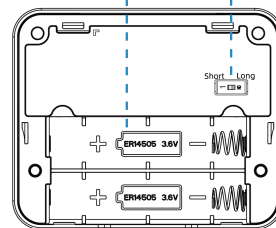

2.3 Button Description

Master Device

Function	Action	Screen
Power On/Off	Press and hold the power button for 5s	Display "Hello" / "GoodBye"

Light Up Screen	Press power button once	Light on
Reset Accumulated People Value	After the screen lights up, press and hold on the power button for 2s	Accumulated counting value reset
Reset to Factory Default	Press and hold on the reset button for 10s	Display reset frames

Node Device

Function	Action	LED Indicator
Power On/Off	Press and hold on the power button for 5s	Power On: Off → On Power Off: On → Off
Check On/Off Status	Press power button once	Light On: device is on Light Off: device is off

2.4 Dimensions (mm)

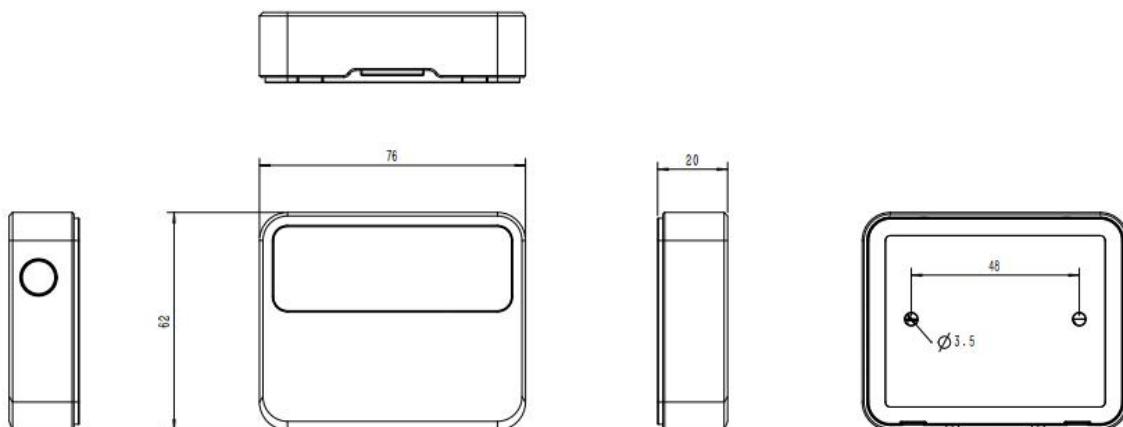

3. Power Supply

Insert the batteries in both the master device and node device for power supply. Press and hold the power button for 5s to turn on the device.

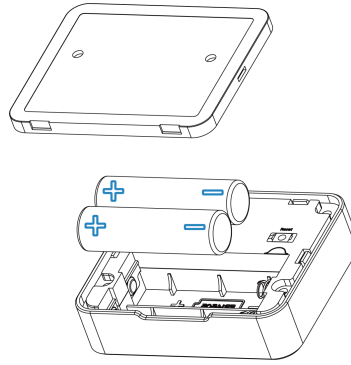
**Note:**

- 1) The device can only be powered by ER14505 Li-SoCl₂ batteries, not alkaline batteries.
- 2) Ensure the batteries direction are not reversed.
- 3) Make sure both batteries are new upon installation, or battery life will reduce.
- 4) The battery should be removed from the device if it is not used for an extended period.

4. Operation Guide

4.1 NFC Configuration

VS360 can be and configured via NFC. Please refer to the following configuration steps.

1. Press power button for 5 seconds to power on both devices.
2. Download and install the Milesight ToolBox App from Google Play or Apple App Store.
3. Enable NFC on your smartphone and launch Milesight ToolBox.
4. Attach the smartphone's NFC area to the master device, and click **NFC Read** to read device information. The basic information and settings of the device will be shown on ToolBox App if it's successfully recognized. You can read and configure the device by tapping the Read/Write device on the App. For better security, please change the password during the first configuration. The default password is **123456**.

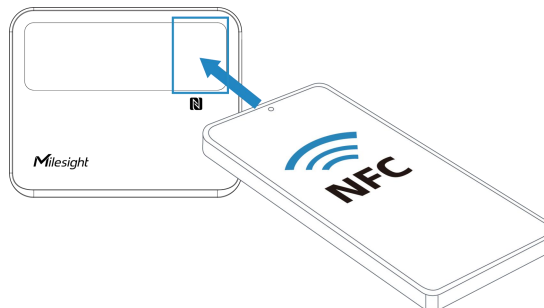
**Note:**

- 1) Locate the NFC detection area on the smartphone and it is recommended to remove your phone case.

- 2) If the smartphone fails to read/write configurations via NFC, detach the phone from the device and try again.
- 3) Only the master device supports NFC and all configurations; the node device can adjust current emission intensity through its back panel to reduce power consumption .

4.2 LoRaWAN® Settings

Configure AppEUI, Join Type, Application Key, and other information. You can also keep all the default settings.

Device EUI
24E124824E308175

* APP EUI
24e124c0002a0001

* Application Port
85

LoRaWAN Version
V1.0.3

Work Mode
Class A

Parameters	Description
Device EUI	Unique ID of the device which can also be found on the label.
App EUI	The default App EUI is 24E124C0002A0001.
Application Port	The port is used for sending and receiving data, the default port is 85.
LoRaWAN® Version	V1.0.2 and V1.0.3 are available.
Work Mode	It's fixed as Class A.
Confirmed Mode	If the device does not receive an ACK packet from the network server, it will resend data once.
Join Type	OTAA and ABP modes are available.
Application Key	Appkey for OTAA mode, the default is 5572404C696E6B4C6F52613230313823.

Network Session Key	Nwkskey for ABP mode, the default is 5572404C696E6B4C6F52613230313823.												
Application Session Key	Appskey for ABP mode, the default is 5572404C696E6B4C6F52613230313823.												
Device Address	DevAddr for ABP mode, the default is the 5th to 12th digits of the SN.												
Channel Mode	Select Standard-Channel mode or Single-Channel mode. When Single-Channel mode is enabled, only one channel can be selected to send uplinks. Please enable Single-Channel mode if connecting to the DS7610.												
Supported Frequency	<p>Enable or disable the frequency to send uplinks.</p> <p>Examples:</p> <p>1, 40: Enabling Channel 1 and Channel 40</p> <p>1-40: Enabling Channel 1 to Channel 40</p> <p>1-40, 60: Enabling Channel 1 to Channel 40 and Channel 60</p> <p>All: Enabling all channels</p> <p>Null: Indicate that all channels are disabled</p> <p>Channel Mode</p> <p>Standard-Channel</p> <p>Enable Channel Index ⓘ</p> <p>0-71</p> <table border="1"> <thead> <tr> <th>Index</th> <th>Frequency/MHz ⓘ</th> </tr> </thead> <tbody> <tr> <td>0 - 15</td> <td>902.3 - 905.3</td> </tr> <tr> <td>16 - 31</td> <td>905.5 - 908.5</td> </tr> <tr> <td>32 - 47</td> <td>908.7 - 911.7</td> </tr> <tr> <td>48 - 63</td> <td>911.9 - 914.9</td> </tr> <tr> <td>64 - 71</td> <td>903 - 914.2</td> </tr> </tbody> </table>	Index	Frequency/MHz ⓘ	0 - 15	902.3 - 905.3	16 - 31	905.5 - 908.5	32 - 47	908.7 - 911.7	48 - 63	911.9 - 914.9	64 - 71	903 - 914.2
Index	Frequency/MHz ⓘ												
0 - 15	902.3 - 905.3												
16 - 31	905.5 - 908.5												
32 - 47	908.7 - 911.7												
48 - 63	911.9 - 914.9												
64 - 71	903 - 914.2												
Rejoin Mode	<p>Reporting interval \leq 35 mins: the device will send a specific number of LinkCheckReq MAC packets to the network server every reporting interval or every double reporting interval to validate connectivity; If there is no response, the device will re-join the network.</p> <p>Reporting interval $>$ 35 mins: the device will send a specific number of LinkCheckReq MAC packets to the network server every reporting interval to validate connectivity; If there is no response, the device will re-join the</p>												

	network. Note: Only OTAA mode supports rejoin mode.
Set the number of packets sent	When the rejoin mode is enabled, set the number of LinkCheckReq packets to send. Note: the actual sending number is Set the number of packet sent + 1 .
ADR Mode	Allow network server to adjust the data rate of the device.
Spreading Factor	If ADR is disabled, the device will send data via this spread factor.
Tx Power	Transmit power of the device.
RX2 Data Rate	RX2 data rate to receive downlinks.
RX2 Frequency	RX2 frequency to receive downlinks. Unit: Hz

Note:

- 1) Please contact sales personnel for device EUI list if there are many units.
- 2) Please contact sales personnel if you need random App keys before purchase.
- 3) Select OTAA mode if you are using Milesight IoT cloud to manage devices.

4.3 General Settings

Reporting Interval(min)

Reset Accumulated Value

Data Storage ⓘ

Report Accumulated Value

Hibernate Mode

Hibernate Period ⌚ 22:00-09:00 >

Screen Power Switch

Counting Mode ⓘ

Parameters	Description
Reporting Interval	The interval of reporting people counting data and battery level sent to network server. Default: 10 min, Range: 1 - 1440 min
Reset Accumulated	Enable or disable to reset accumulated in/out counting values.

Value	Note: the device will reset automatically when accumulate counting values reaches 65535 even this option is disabled.
Reset Time	The time to reset accumulated in/out counting values. Note: The cumulative value will be reported once before reset.
Data Storage	Disable or enable data storage locally.
Data Retransmission	Disable or enable data retransmission.
Report Accumulated Value	Disable or enable to report accumulated counting values in periodic packets.
Hibernate Mode	Disable or enable Hibernate mode and configure the Hibernation Period. It will stop counting and reporting when hibernating.
Hibernate Period	Set hibernation period.
Screen Power Switch	Enable or disable screen display. The display content includes battery level, people counting and align status.
Counting Mode	High Traffic Period Mode: Suitable for scenarios with high foot traffic. Low Traffic Period Mode: Suitable for scenarios with low foot traffic.
Change Password	Change the password for ToolBox App to write this device.

4.4 Advanced Settings

4.4.1 Threshold Settings

Go to **Device > Settings > Threshold Settings** of ToolBox App to enable and configure the threshold settings. If the threshold is triggered, the device will report the threshold alarm packet instantly.

Periodic People Count

In >

Out >

Cumulative People Count

Accumulated In >

Accumulated Out >

4.4.2 Data Storage

VS360 supports the storage of 1000 data records locally and exports data via ToolBox App. The device will record the data according to the reporting interval even if it is disconnected from the network. **Note that VS360 only stores periodic counting data.**

1. Go to **Device > Status** of ToolBox App to sync the device time.

Device Time 2023-08-08 19:22

2. Go to **Device > Setting > General Settings** to enable the data storage feature.

Data Storage 

Data Retransmission 

3. Go to **Device > Maintenance** of ToolBox App, click **Export Historical Period**, then select the data time range and click **Confirm** to export data. The maximum export data period on ToolBox App is 14 days.

Year	Day	Count	Total
2021	6	17	42
2022	7	18	43
2023	8	19	44
		2	45
		3	46

4. Click **View Export Records** to find the export file records.



Note: Swipe the file record to the left to delete .

5. Click **Data Cleaning** to clear all stored data inside the device if necessary.

Historical Data



4.4.3 Data Retransmission

VS360 supports data retransmission to ensure the network server can receive all data even if the network is down for some time. There are two ways to retrieve the lost data:

- Network server sends downlink commands to enquire the historical data for a specified time range, refer to section [Historical Data Enquiry](#);
- When network is down and no response is received from LinkCheckReq MAC packets for a period of time, the device will record the time of disconnection and retransmit the lost data after the device is reconnected to the network.

Here are the steps of data retransmission:

1. Go to **Device > Status** of ToolBox App to sync the device time.

Device Time 2023-08-08 19:22 Sync

2. Go to **Device > Setting > General Settings** to enable data storage feature and data retransmission feature.



3. Go to **Device > Setting > LoRaWAN Settings** to enable rejoin mode feature and set the number of packets sent. Take below as an example, the device will send LinkCheckReq MAC packets to the network server regularly to check for any network disconnection; if there is no response for 8+1 times, the join status will change to de-active and the device will record a data lost time point (the time it reconnected to the network).

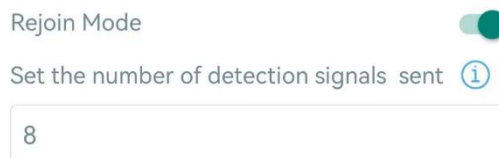

4. After reconnecting to the network, the device will send the lost data from the point of time when the data was lost according to the data re-transmission reporting interval.

Note:

- 1) If the device is rebooted or re-powered during the data retransmission process, the device will re-send interrupted data during the retransmission period again after the device is reconnected back to the network.
- 2) If the network is disconnected again during data retransmission, the device will only send the latest disconnected data.
- 3) The retransmission data format starts with "20ce", please refer to section [Historical Data Enquiry](#).
- 4) Data retransmission will increase the uplinks and shorten the battery life.

4.4.4 Milesight D2D Settings

Milesight D2D protocol is developed by Milesight and is used for connection among Milesight devices without a gateway. When the Milesight D2D setting is enabled, VS360 can work as a Milesight D2D controller to send control commands to trigger Milesight D2D agent devices.

1. Configure RX2 data rate and RX2 frequency in LoRaWAN[®] settings, it is suggested to change the default value if there are many LoRaWAN[®] devices around.
2. Go to **Device > Settings > D2D Settings** to enable D2D function and configure the D2D settings.

Enable

D2D Key

Someone Entered

Control command

LoRa Uplink ⓘ

Control Time /min ⓘ

Someone Left

People Counting Threshold Triggered

Parameters	Description
Enable	Enable or disable Milesight D2D feature.
D2D Key	Define a unique D2D key which is the same as the setting in D2D agent devices. Default value: 5572404C696E6B4C6F52613230313823
Status Condition	<p>When VS360 detects one or more of the below status, it will send the control command to the corresponding Milesight D2D agent devices:</p> <ul style="list-style-type: none"> ● Someone entered ● Someone Left ● People Counting Threshold Triggered <p>Note: for people counting conditions, please enable and configure the threshold feature under Threshold Settings.</p>
Control command	Define a 2-byte hexadecimal control command (0x0000 to 0xffff).
LoRa Uplink	If enabled, a LoRaWAN® uplink packet that contains the counting value alarm will be sent to gateway after the Milesight D2D control command is sent.
Control Time /min ¹	<p>After receiving commands from VS360, Milesight D2D agent devices will take corresponding actions within this duration.</p> <p>Default: 5 mins, Range: 1 ~ 1440 mins</p>

¹ This feature is under development on Milesight D2D agent devices.

4.5 Maintenance

4.5.1 Backup

VS360 supports backup templates for quick and easy device configurations in bulk. The backup feature is only for devices with the same model and LoRaWAN® frequency band.

1. Go to **Template** page on the App and save the current settings as a template. The saved templates are also editable.



2. Select one saved template and click **Write**, then attach the smartphone to another device via NFC to reuse the template.

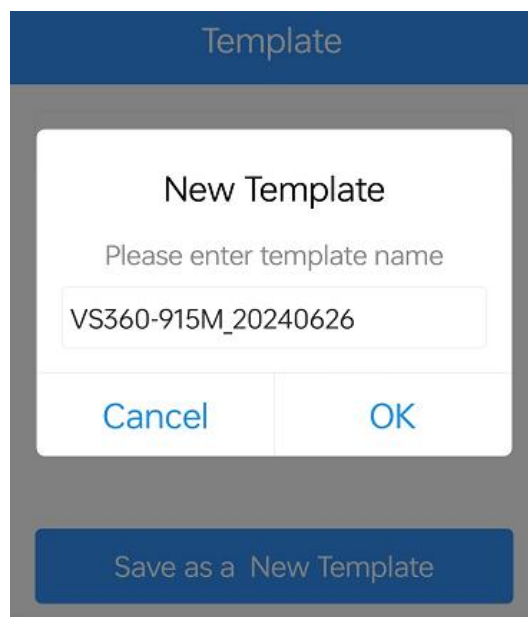

Note: Swipe the template item to the left to edit or delete the template. Click the template to edit the configurations.

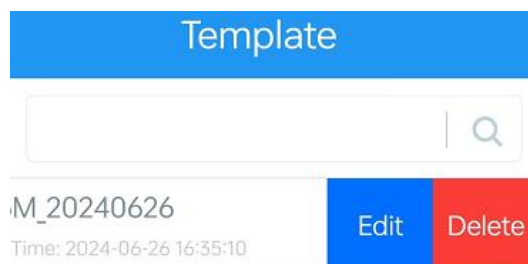

4.5.2 Upgrade

1. Download firmware from the Milesight website to your smartphone.

2. Go to **Device > Maintenance** of ToolBox App, tap **Browse** to import firmware and upgrade the device.

Note: Operation on ToolBox is not supported during the upgrade.

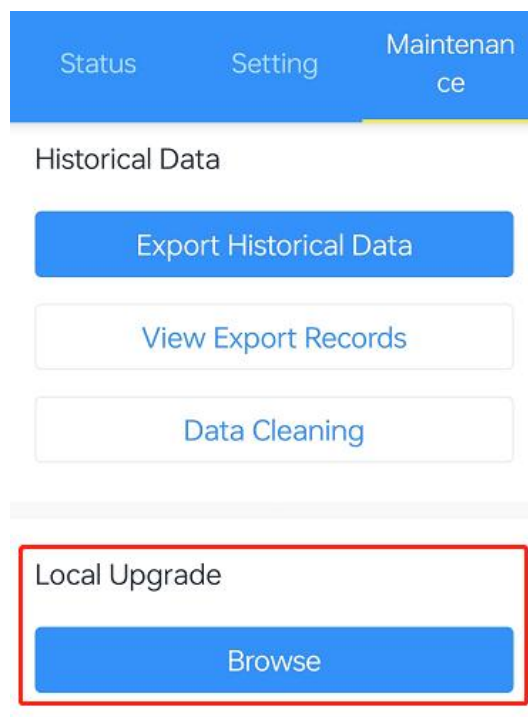

4.5.3 Reset to Factory Default

VS360 supports two methods to reset the device, which are as follows:

Via Hardware: Press and hold on the master device's reset button for 10s .

Via ToolBox App: Go to **Device > Maintenance** to tap **Restore Factory Settings**, then attach the smartphone to the device via NFC to complete the reset.

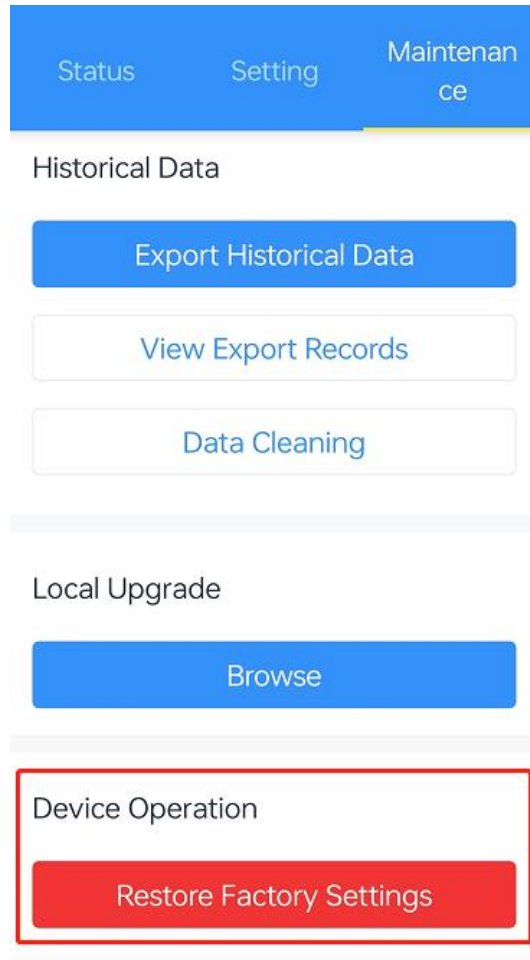

5. Installation Instruction

5.1 Installation

Node Device

Determine the node device's installation location first. Then choose one of ways to fix:

- **Fixed by 3M Tape**

Paste 3M tape to the back of device, tear the other side and attach it to the wall or other surfaces.

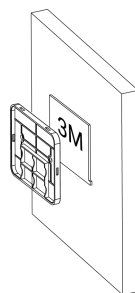

● Fixed by Mounting Kits

1. Take off the back cover of the device, and drill 2 holes in the wall according to the mounting holes on the cover.
2. Fix the wall plugs into the wall, then fix the back cover to wall plugs with screws.
3. Install the device back to the cover.

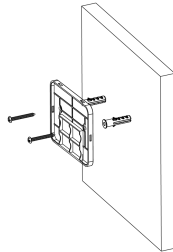

Master Device

1. Align the master device with the node device.
2. Ensure the screen is not blocked, press the power button to check alignment result.
3. Adjust the device according to the prompt on the screen, and mark the installation position. Remember to press the power button to refresh the alignment result after you make any adjustments.
4. Fix the master device by 3M tape or wall screw mount kits following the installation steps of the node device aforementioned. (Pictures are installed on the right side for example)

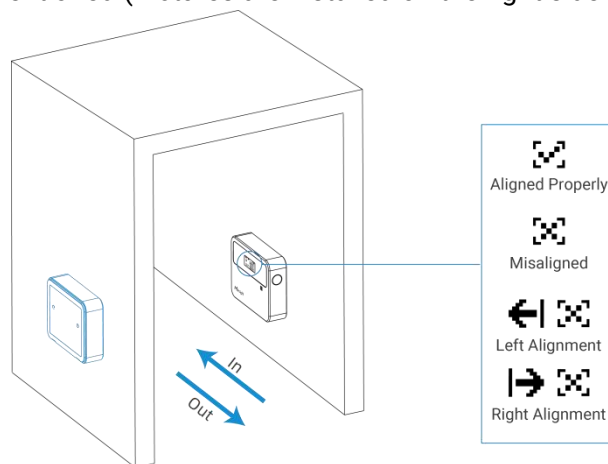

Installation Note:

1. Ensure that there is no object between the master device and node device, both devices are aligned parallel to each other.
2. Avoid exposing the device to direct sunlight.
3. The best installation height is 0.7~1.2m from the ground.
4. The recommended detection range is 1.2~3m. When the range is no more than 2m, it is

suggested to adjust DIP switch of node device to **Short** position; when the range is more than 2m, switch to **Long** position.

5. Avoid exposing the master device to areas where an IR device is around (IR remote controller, etc.).
6. Avoid placing the device near reflective surfaces like glass.

5.2 Uninstallation

Place your thumb on top of the device, grip the bottom of the device with your other fingers, and pull it out diagonally to remove the device.

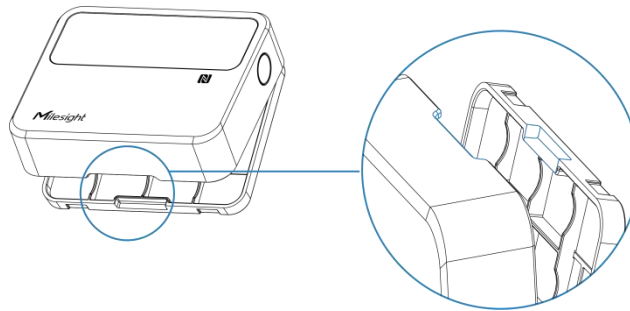

5.3 Factors Affecting Accuracy

- Two people passing through side by side will be counted as one person.
- Holding something with your hand raised or pushing a shopping cart may result in overcounting.
- Walking in an speed more than 1.5m/s may lead to data not being recorded.
- When a single person closely follows another (with a distance of less than 20 cm), there is a chance of missing the count.
- Passing close to the node device or passing at an angle may result in reverse counting.

6. Device Payload

All the data is based on the following format (HEX), the Data field should follow the little-endian:

Channel1	Type1	Data1	Channel2	Type2	Data2	Channel 3	...
1 Byte	1 Byte	N Bytes	1 Byte	1 Byte	M Bytes	1 Byte	...

For decoder examples please find the files on

<https://github.com/Milesight-IoT/SensorDecoders>.

6.1 Basic Information

VS360 sensor reports basic information whenever it joins the network.

Channel	Type	Byte	Description
---------	------	------	-------------

ff	0b (Power On)	1	Device is on
	01 (Protocol Version)	1	01=>V1
	16 (Device SN)	8	16 digits
	09 (Hardware Version)	2	01 40 => V1.4
	0a (Firmware Version)	2	01 14 => V1.14
	0f (Device Type)	1	00: Class A

Example:

ff0bff ff0101 ff166824e30817560003 ff090100 ff0a0101 ff0f00					
Channel	Type	Value	Channel	Type	Value
ff	0b (Power On)	ff (Reserved)	ff	01 (Protocol Version)	01 (V1)
Channel	Type	Value	Channel	Type	Value
ff	16 (Device SN)	6824e30817560 003	ff	09 (Hardware Version)	0100 (V1.0)
Channel	Type	Value	Channel	Type	Value
ff	0a (Firmware Version)	0101 (V1.1)	ff	0f (Device Type)	00 (Class A)

6.2 Sensor Data

Item	Channel	Type	Byte	Description
Battery Level	01	75	1	UINT8, Unit: %, master battery level
	02			UINT8, Unit: %, node battery level, update only once everyday
Accumulated Counter	04	cc	4	<ul style="list-style-type: none"> Byte 1-2: Accumulated In Byte 3-4: Accumulated Out
Periodic Counter	05	cc	4	<ul style="list-style-type: none"> Byte 1-2: Periodic In Byte 3-4: Periodic Out
Accumulated Counter Alarm	84	cc	5	<ul style="list-style-type: none"> Byte 1-2: Accumulated In Byte 3-4: Accumulated Out Byte 5: 01
Periodic Counter Alarm	85	cc	5	<ul style="list-style-type: none"> Byte 1-2: Periodic In Byte 3-4: Periodic Out Byte 5: 01
Abnormal Alarm	03	f4	2	<ul style="list-style-type: none"> Byte 1:

				00-Counting anomaly, 01-Node Device Without Response, 02-Devices Misaligned. <ul style="list-style-type: none"> Byte 2: 00-Alarm dismiss, 01-Alarm
--	--	--	--	--

Examples:

1. Periodic packet: report as reporting interval (10 minutes by default).

017562 027562 05cc09000500 04cc09000200					
Channel	Type	Value	Channel	Type	Value
01	75 (Master Battery Level)	62=>98%	02	75 (Node Battery Level)	62=>98%
Channel	Type	Value	Channel	Type	Value
05	cc	Periodic In: 09 00=> 00 09=9 Periodic Out: 05 00=> 00 05=5	04	cc	Accumulated In: 09 00=> 00 09=9 Accumulated Out: 02 00=> 00 02=2

2. People alarm packet: report when the periodic counting value reaches the threshold.

85cc 06000000 01		
Channel	Type	Value
85	cc	Periodic in: 0600=>0006=6 Periodic out: 0000=0 01= Threshold Alarm

3. Abnormal Alarm: report when device is obstructed by an obstacle.

03f4 00 01		
Channel	Type	Value
03	f4	00 = Counting anomaly. 01= Alarm

6.3 Downlink Commands

VS360 supports downlink commands to configure the device. The application port is 85 by default.

Channel	Item	Type	Byte	Description
ff	Reboot	10	1	ff

Reporting Interval	8e	3	<ul style="list-style-type: none"> ● Byte 1: 00 ● Byte 2-3: interval time, unit: min
Reset Accumulated Value	a6	1	01: enable, 00: disable
Accumulated Counter Clearing	a8	1	01: clear accumulate In counter 02: clear accumulate Out counter
Reset Accumulated Time	ed	3	<ul style="list-style-type: none"> ● Byte 1: Reset date 00: Everyday; 01: Every Sunday; 02: Every Monday; 03: Every Tuesday ; 04: Every Wednesday; 05: Every Thursday; 06: Every Friday; 07: Every Saturday ● Byte 2: Reset hour ● Byte 3: Reset minute
Data Storage	68	1	01-enable, 00-disable
Data Retransmission	69	1	01-enable, 00-disable
Retransmission Interval	6a	3	<ul style="list-style-type: none"> ● Byte 1: 00 ● Byte 2-3: interval time, unit:s range: 30~1200s (600s by default)
Report Accumulated Value	a9	1	01-enable, 00-disable
Hibernate Period	75	6	<ul style="list-style-type: none"> ● Byte 1: 01-enable, 00-disable ● Byte 2-3: Start Time, unit: min ● Byte 4-5: End Time, unit: min ● Byte 6: Set Hibernate Period, <ul style="list-style-type: none"> ➢ Bit0=1 ➢ Bit7~Bit1: Sunday~Monday <p>Note: if start time equals end time, it means all day.</p>
Screen Power Switch	fd	1	01: enable, 00: disable
Counting Mode	fc	1	02: Suitable for scenarios with high foot traffic, 03: Suitable for scenarios with low foot traffic.
Threshold Alarm	06	9	● Byte 1:

			<ul style="list-style-type: none"> ➤ Bit0~Bit2: <ul style="list-style-type: none"> 000-disable 001-below (minimum threshold) 010-over (maximum threshold) 011-within 100-below or over ➤ Bit3~Bit5: <ul style="list-style-type: none"> 001-Periodic Counter threshold 010-Accumulated Counter threshold ➤ Bit6~Bit7: 11 ● Byte 2-3: Min.value ● Byte 4-5: Max. value ● Byte 6-9: 00000000
Milesight D2D Feature	84	1	01: enable; 00: disable
Milesight D2D Key	35	8	First 16 digits, last 16 digits are fixed as 0
Milesight D2D Settings	96	8	<ul style="list-style-type: none"> ● Byte 1: <ul style="list-style-type: none"> 01-Someone Entered 02-Someone Left 03-People Counting Threshold Triggered ● Byte 2: 01-enable, 00-disable ● Byte 3: <ul style="list-style-type: none"> 01-enable LoRa Uplink, 00-disable LoRa Uplink ● Byte 4-5: D2D control command ● Byte 6-7: control time, unit: min ● Byte 8: <ul style="list-style-type: none"> 00-disable control time, 01-enable control time

Examples:

1. Reboot the device.

ff10ff		
Channel	Type	Value
ff	10 (Reboot)	ff (Reserved)

2. Set reporting interval as 2 minutes.

ff8e 00 0200		
Channel	Type	Value
ff	8e (Reporting Interval)	02 00=>00 02=>2 mins

3. Set Reset Accumulated Counter Time as Every Sunday 12: 20.

ffed 01 0c 14		
Channel	Type	Value
ff	ed (Reset Accumulated Counter Time)	01=>Every Sunday Reset hour: 0c => 12 Reset minute: 14=> 20

4. Set Milesight D2D Key as 5572404C696E6B4C0000000000000000.

ff35 5572404C696E6B4C		
Channel	Type	Value
ff	35 (Set D2D Key)	5572404C696E6B4C

5. Set Milesight D2D settings.

ff96 03 01 01 04e0 0500 01		
Channel	Type	Value
ff	96 (D2D Settings)	03=> People counting threshold triggered; 01=>Enable; 01=>Enable LoRa Uplink; 04 e0=>e0 04, Control Command is e0 04; 05 00=>00 05, Control time is 5 mins; 01=>Enable Control Time

6. Set Counting Mode as High foot traffic.

fffc 02		
Channel	Type	Value
ff	fc (Counting Mode)	02=> High foot traffic

7. Set people counting threshold alarm.

ff06 d4 9600 2c01 00000000		
Channel	Type	Value
ff	06 (Threshold Alarm)	d4=>11 010 100 100=below or over Min_value: 96 00=>00 96=15 Max_value: 2c 01=>01 2c=30

6.4 Historical Data Enquiry

VS360 supports sending downlink commands to enquire historical data for a specified time point or time range. Before that, ensure that **the device time is correct and the data storage feature was enabled to store the data.**

Command format:

Channel	Type	Byte	Description
fd	6b (Enquire data in time point)	4	Unix timestamp
fd	6c (Enquire data in time range)	8	<ul style="list-style-type: none"> Byte 1-4: Start time, Unix timestamp Byte 5-8: End time, Unix timestamp
fd	6d (Stop query data report)	1	ff
ff	6a (Report Interval)	3	<ul style="list-style-type: none"> Byte 1: 01 Byte 2: Interval time, unit: s, range: 30~1200s (60s by default)

Reply format:

Channel	Type	Byte	Description
fc	6b/6c	1	00: data enquiry success 01: time point or time range invalid 02: no data in this time or time range
20	ce (Historical Data)	9/13	<ul style="list-style-type: none"> Byte 1-4: Unix Timestamp Byte 5: <ul style="list-style-type: none"> 00-Periodic Counter 01-Periodic Counter + Accumulated Counter Byte 6-7: Periodic In Counter Byte 8-9: Periodic Out Counter Byte 10-11: Accumulated In Counter Byte 12-13: Accumulated Out Counter

Note:

1. The device only uploads no more than 300 data records per range enquiry.
2. When enquiring the data at a specific time point, it will upload the data which is the closest to the search point within the reporting interval range. For example, if the device's reporting interval is 10 minutes and users send a command to search for data stored at 17:00, it will upload these data, if the device finds any data stored in 17:00. If not, it will search for data between 16:50 to 17:10 and upload the data which is closest to 17:00.

Example:

1. Enquire historical data between 2023/8/28 13:30:00 to 2023/8/28 13:40:00.

fd6cd830ec643033ec64		
Channel	Type	Value
fd	6c (Enquire data in time range)	Start time: d830ec64=> 64ec30d8 = 1693200600s = 2023/8/28 13:30:00 End time: 3033ec64 => 64cc3330 = 1693201200s = 2023/8/28 13:40:00

Reply:

fc6c00		
Channel	Type	Value
fc	6c (Enquire data in time range)	00: data enquiry success

20ce 1932ec64 01 0700 0300 4a00 3800			
Channel	Type	Time Stamp	Value
20	ce (Historical Data)	1932ec64 => 64ec3219 = 1693200921s = 2023/8/28 13:35:21	01=Periodic Counter + Accumulated Counter Period In: 0700=>0007=7 Period Out: 0300=>0003=3 Accumulated In: 4a00=>004a=74 Accumulated Out: 3800=>0038=56

-END-