

IoT Controller

UC300

User Guide



Safety Precautions

Milesight will not shoulder responsibility for any loss or damage resulting from not following the instructions of this operating guide.

- ❖ The device must not be remodeled in any way.
- ❖ Do not place the device close to objects with naked flames.
- ❖ Do not place the device where the temperature is below/above the operating range.
- ❖ Power off the device when installing or wirings.
- ❖ Make sure electronic components do not drop out of the enclosure while opening.
- ❖ The device must never be subjected to shocks or impacts.

Declaration of Conformity

UC300 is in conformity with the essential requirements and other relevant provisions of the CE, FCC, and RoHS.



Copyright © 2011-2022 Milesight. All rights reserved.

All information in this guide is protected by copyright law. Whereby, no organization or individual shall copy or reproduce the whole or part of this user guide by any means without written authorization from Xiamen Milesight IoT Co., Ltd.

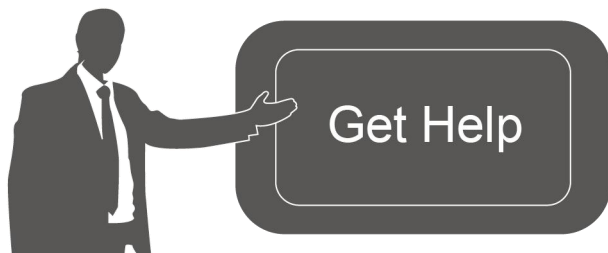

For assistance, please contact
Milesight technical support:
Email: iot.support@milesight.com
Tel: 86-592-5085280
Fax: 86-592-5023065

Address: Building C09, Software Park III,
Xiamen 361024, China

Revision History

Date	Doc Version	Description
Mar. 17, 2022	V 1.0	Initial version

Contents

1. Product Introduction.....	4
1.1 Overview.....	4
1.2 Features.....	4
2. Hardware Introduction.....	4
2.1 Packing List.....	4
2.2 Hardware Overview.....	5
2.3 Application Wiring.....	5
2.4 LED Indicators.....	6
2.5 Reset Button.....	7
2.6 Dimensions (mm).....	7
3. Hardware Installation.....	7
3.1 SIM Installation (Cellular Version Only).....	7
3.2 Antenna Installation.....	7
3.3 Device Installation.....	8
3.3.1 Wall Mounting.....	8
3.3.2 DIN Rail Mounting.....	8
4. Operation Guide.....	9
4.1 Log in the ToolBox.....	9
4.2 Communication Settings.....	11
4.2.1 LoRaWAN Settings (LoRaWAN Version Only).....	11
4.2.2 Cellular & Application Settings (Cellular Version Only).....	13
4.2.3 SMS Settings (Cellular Version Only).....	17
4.3 Data Interface Settings.....	18
4.3.1 Basic Settings.....	18
4.3.2 Digital Input/Pulse Settings.....	19
4.3.3 Digital Output Settings.....	20
4.3.4 RS485 Settings.....	20
4.3.5 RS232 Settings.....	22
4.3.6 Analog/PT100 Settings.....	24
4.4 IF-THEN Command.....	25
4.5 LoRa D2D Settings (LoRaWAN Version Only).....	28
4.6 Maintenance.....	30
4.6.1 Upgrade.....	30
4.6.2 Backup.....	31
4.6.3 Reset to Factory Default.....	31
5. Device Payload.....	32

1. Product Introduction

1.1 Overview

UC300 is an IoT controller used for remote control and data acquisition from multiple sensors. It contains different I/O interfaces such as analog inputs, digital inputs, relay outputs, serial ports and so on, which support remote device data transmission and control via LoRaWAN®, 3G/4G networks or SMS. Besides, UC300 supports multiple trigger conditions and actions which works autonomously even when the network drops.

1.2 Features

- Easy to connect with diverse wired sensors through DI/DO/AI/PT100/RS232/RS485 interfaces
- Support LoRaWAN® or 3G/4G wireless communication
- Multiple triggering conditions and actions
- Embedded watchdog for work stability
- Industrial metal case design with wide operating temperature range
- Compliant with standard LoRaWAN® gateways and network servers
- Quick and easy management with Milesight IoT Cloud solution

2. Hardware Introduction

2.1 Packing List

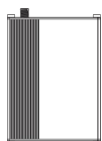

1 × UC300 Device



1 × LoRa/Cellular
Antenna

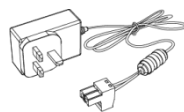

1 ×
Power Adapter



5 × Terminal Blocks

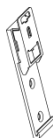

1 × DIN Rail
Mounting Clip



4 × Wall Mounting
Kits



4 × Fixing Screws



1 ×
Quick Start Guide

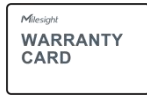

1 × Warranty
Card

! If any of the above items is missing or damaged, please contact your sales representative.

2.2 Hardware Overview

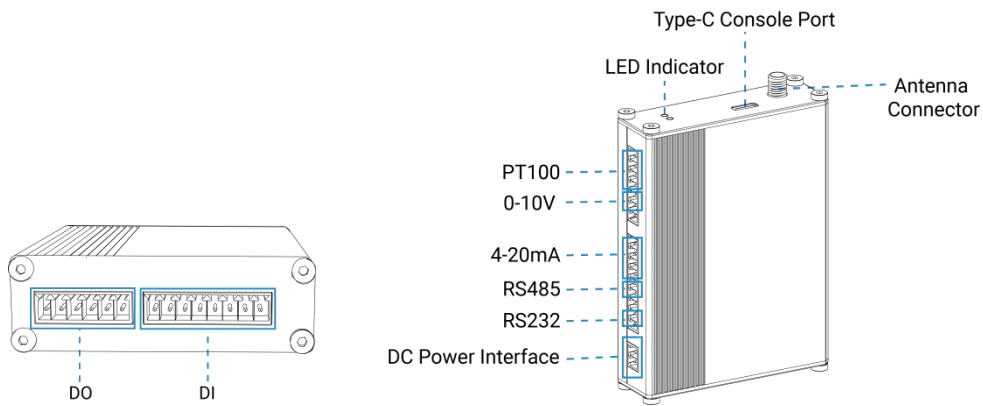

2.3 Application Wiring

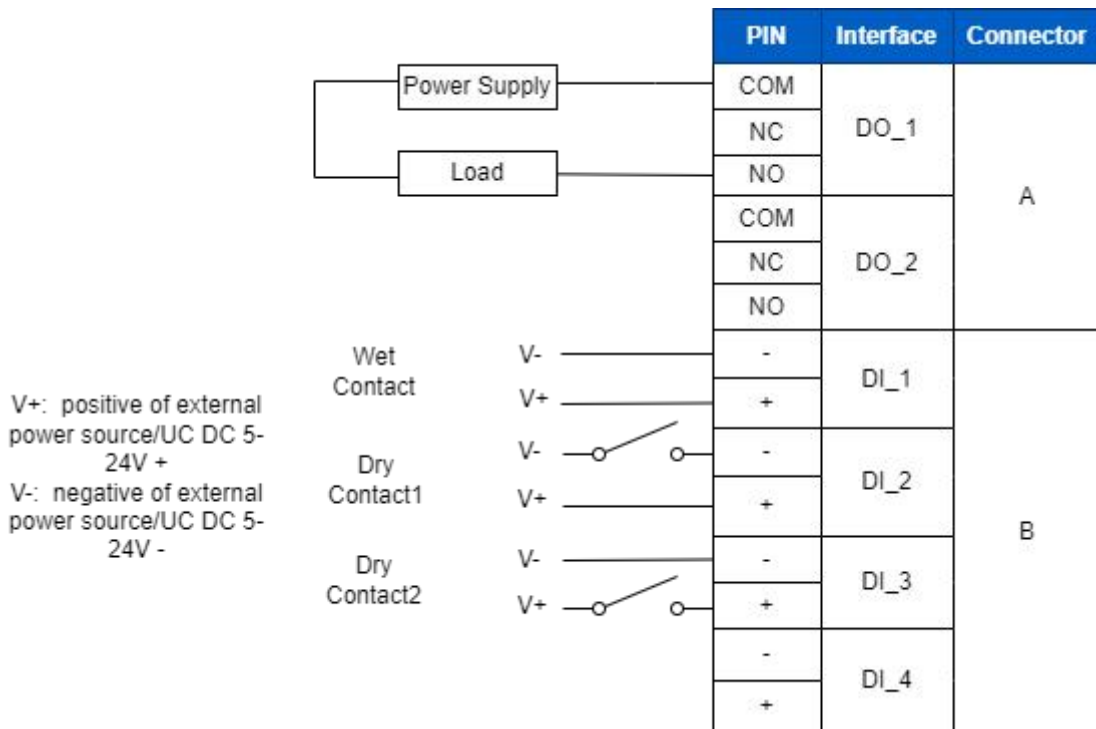

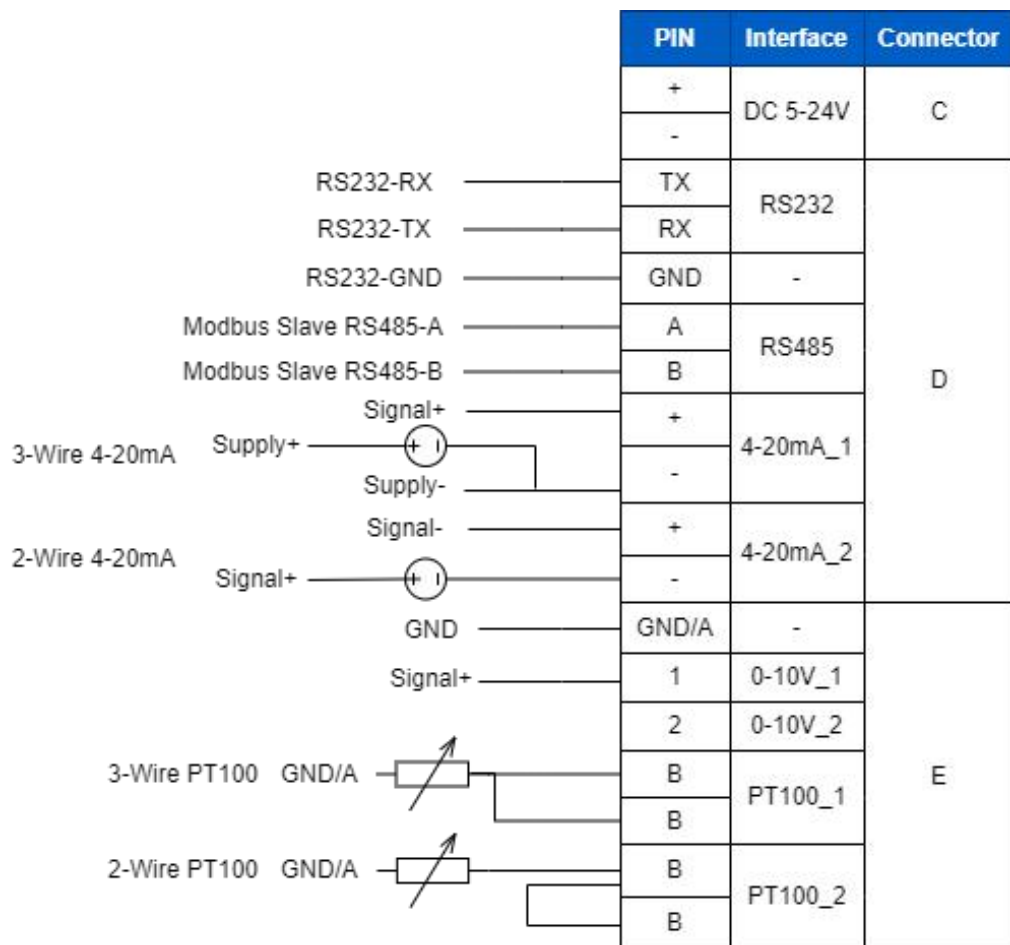

RS485 Terminal Resistor:

DIP Switch	Description
1 on 2 off 3 off	Add 120 Ω resistor between A and B
1 off 2 on 3 off	Add pull-down resistor on B
1 off 2 off 3 on	Add pull-up resistor on A

2.4 LED Indicators

LED	Indication	Status	Description
SYS	System Status	Static On	System works
		Slowly Blinks	Fail to acquire data from data interfaces
		Static On	System error
ACT	Network Status	Off	Not join/register to network
		Blinks as Requests	Send join network requests or registering network requests
		Blinks Twice → Static On	Succeed to join/register to network
		Blinks Once	Succeed to send uplinks
		Blinks Twice	Fail to send uplinks
		Blinks Twice	Receive downlinks

2.5 Reset Button

There is reset button inside the device.

Function	Description	
	SYS LED	Action
Reset	Static Green	Press and hold the reset button for more than 10 seconds.
	Static Green → Rapidly Blinking	Release the button and wait.
	Off → Static Green	The device resets to factory default.

2.6 Dimensions (mm)

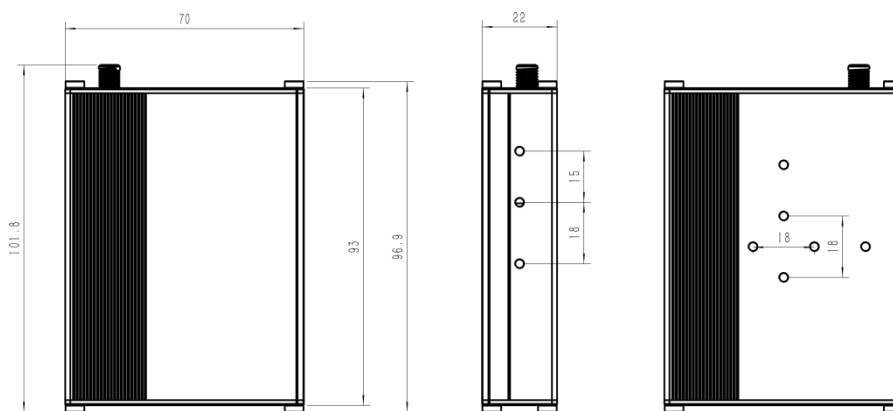

3. Hardware Installation

3.1 SIM Installation (Cellular Version Only)

Release the screws and cover on the antenna connector, insert the SIM card into the slot. If you want to take out the SIM card, press it to make it pop out.

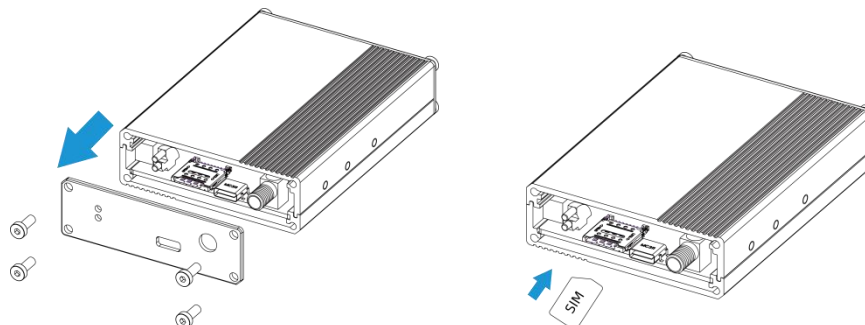

3.2 Antenna Installation

Rotate the antenna into the antenna connector accordingly.

The external antenna should be installed vertically always on a site with a good signal.

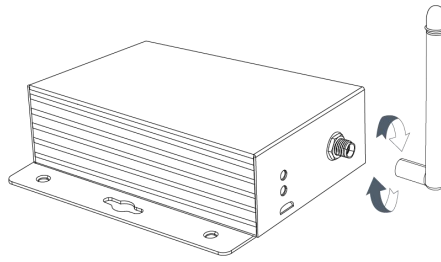

3.3 Device Installation

UC300 device can be placed on a desktop or mounted to a wall or a DIN rail.

3.3.1 Wall Mounting

1. Fix the wall mounting bracket to the device with 2 screws.

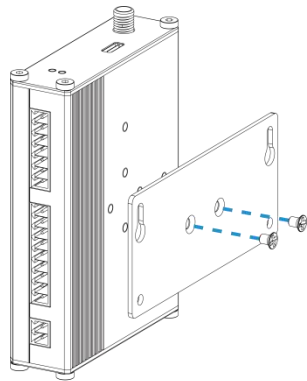

2. Drill 4 holes on the wall according to the bracket, then fix the wall plugs into the wall.

3. Fix the device to the wall plugs with screws. When installation, it's suggested to fix the two screws on the top at first.

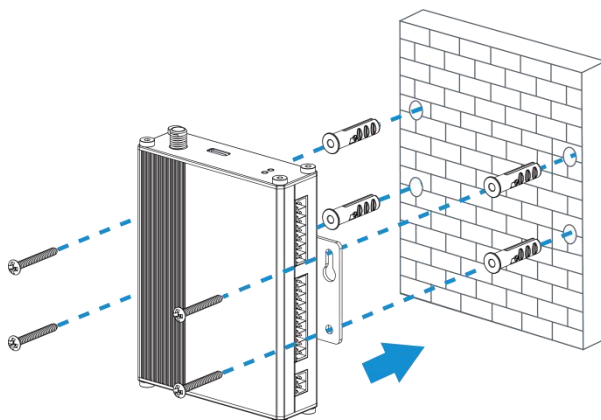

3.3.2 DIN Rail Mounting

1. Fix the mounting clip to the device with 3 screws.

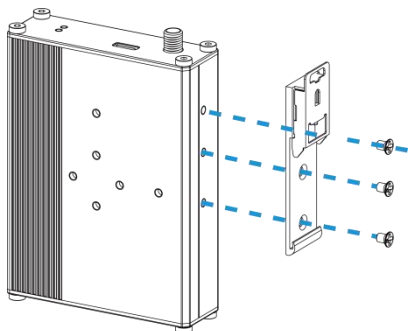

You can also try below installation methods:

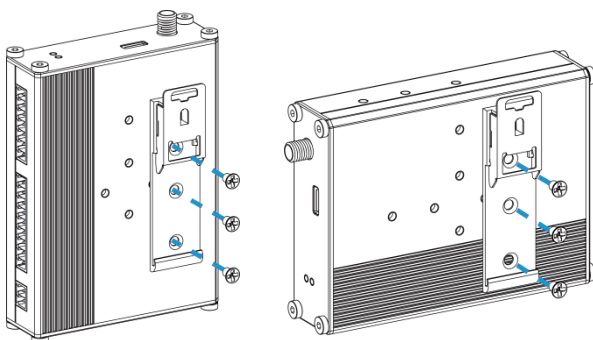

2. Hang the device to the DIN rail. The width of DIN rail is 3.5cm.

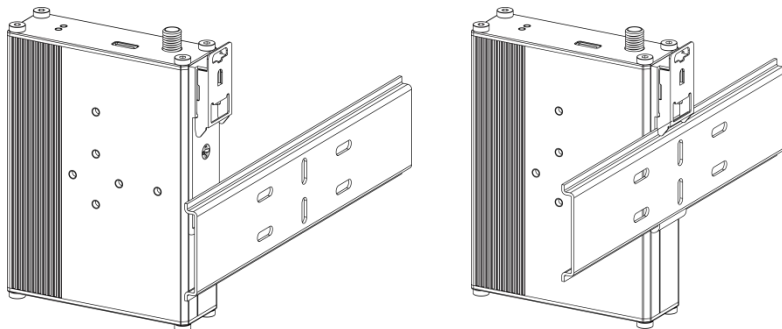

4. Operation Guide

4.1 Log in the ToolBox

1. Download ToolBox software from [Milesight IoT website](https://www.milesight-iot.com).
2. Power on the UC300 device, then connect it to computer via type-C port.

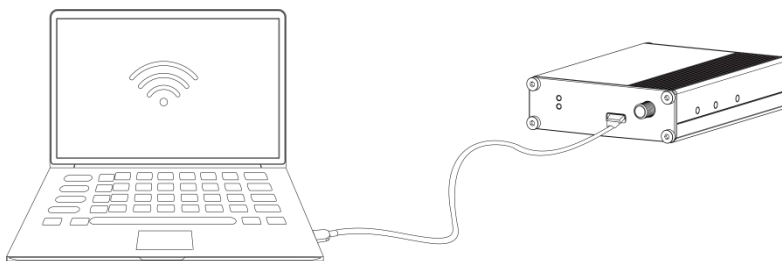

- Open the ToolBox and select type as "General", then click password to log in ToolBox.
(Default password: **123456**)

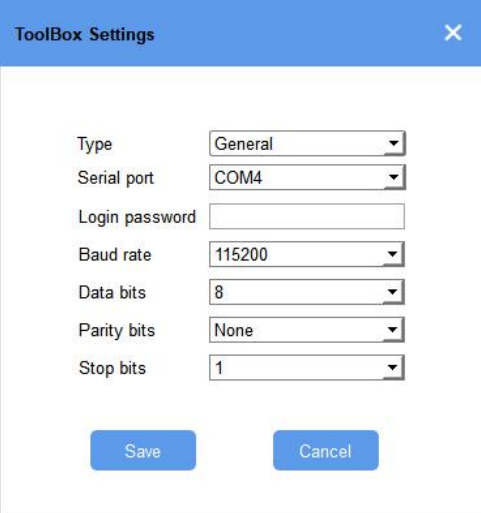

Type	General
Serial port	COM4
Login password	
Baud rate	115200
Data bits	8
Parity bits	None
Stop bits	1

Save Cancel

- After logging in the ToolBox, you can change device settings.

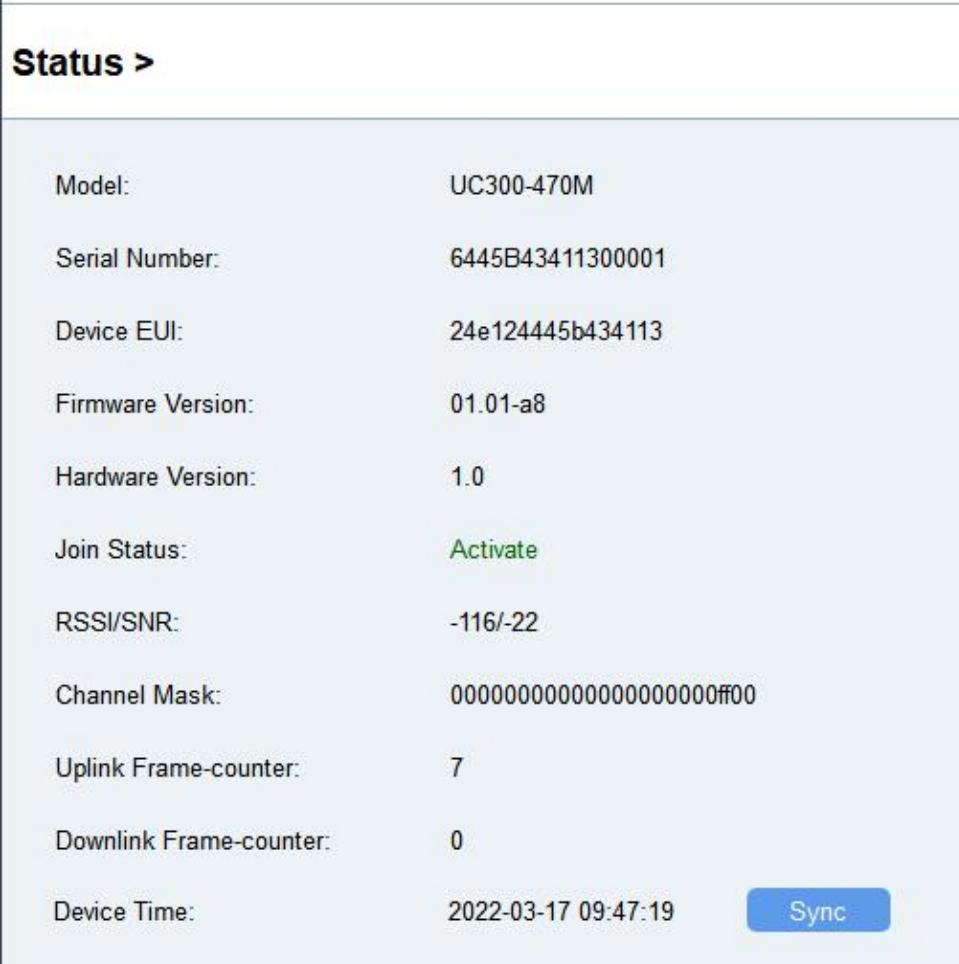

Model:	UC300-470M
Serial Number:	6445B43411300001
Device EUI:	24e124445b434113
Firmware Version:	01.01-a8
Hardware Version:	1.0
Join Status:	Activate
RSSI/SNR:	-116/-22
Channel Mask:	000000000000000000#00
Uplink Frame-counter:	7
Downlink Frame-counter:	0
Device Time:	2022-03-17 09:47:19

Sync

4.2 Communication Settings

4.2.1 LoRaWAN Settings (LoRaWAN Version Only)

LoRaWAN settings is used for configuring the transmission parameters in LoRaWAN® network and is only applied to UC300 LoRaWAN® version.

Basic LoRaWAN Settings:

Go to “**LoRaWAN Settings -> Basic**” to configure join type, App EUI, App Key and other information. You can also keep all settings by default.

Device EUI	<input type="text" value="24E124445B434113"/>
App EUI	<input type="text" value="24E124C0002A0001"/>
Application Port	<input type="text" value="85"/>
Join Type	<input type="text" value="OTAA"/>
Class Type	<input type="text" value="Class C"/>
Application Key	<input type="text" value="*****"/>
RX2 Date Rate	<input type="text" value="DR0 (SF12, 125 kHz)"/>
RX2 Frequency	<input type="text" value="505300000"/>
Spread Factor	<input type="text" value="SF10-DR2"/>
Confirmed Mode	<input type="checkbox"/>
Rejoin Mode	<input checked="" type="checkbox"/>
Set the number of packets sent	<input type="text" value="32"/> packets
ADR Mode	<input checked="" type="checkbox"/>
TXPower	<input type="text" value="TXPower0-19.15 dBm"/>

Parameters	Description
Device EUI	Unique ID of the device on the label.
App EUI	Default App EUI is 24E124C0002A0001.
Application Port	The port used for sending and receiving data (RS232 data excluded), default port is 85.
Working Mode	Fixed as Class C.
Join Type	OTAA and ABP modes are available.
Application Key	Appkey for OTAA mode, default is 5572404C696E6B4C6F52613230313823.
Device Address	DevAddr for ABP mode, default is the 5 th to 12 th digits of SN.
Network Session	Nwkskey for ABP mode, default is 5572404C696E6B4C6F52613230313823.

Key	
Application Session Key	Appskey for ABP mode, default is 5572404C696E6B4C6F52613230313823.
RX2 Data Rate	RX2 data rate to receive downlinks.
RX2 Frequency	RX2 frequency to receive downlinks. Unit: Hz
Spread Factor	If ADR is disabled, the device will send data via this spread factor.
Confirmed Mode	If the device does not receive ACK packet from network server, it will resend data 3 times at most.
Rejoin Mode	Reporting interval \leq 30 mins: device will send specific mounts of LoRaMAC packets to check connection status every 30 mins; If not receiving response after specific packets, the device will re-join. Reporting interval $>$ 30 mins: device will send specific mounts of LoRaMAC packets every to check connection status every reporting interval; If not receiving response after specific packets, the device will re-join.
ADR Mode	Allow network server to adjust datarate of the device.
Tx Power	Transmit power of device.

Note:

- 1) Please contact sales for device EUI list if there are many units.
- 2) Please contact sales if you need random App keys before purchasing.
- 3) Select OTAA mode if you use Milesight IoT Cloud to manage devices.
- 4) Only OTAA mode supports rejoin mode.

LoRaWAN Frequency Settings:

Go to “**LoRaWAN Settings -> Channel**” to select supported frequency and select channels to send uplinks. Make sure the channels match the LoRaWAN® gateway.

Basic
Channel

Support Frequency : EU868

<input type="checkbox"/>	Index	Frequency/MHz	Max Datarate	Min Datarate
<input checked="" type="checkbox"/>	0	<input style="width: 80px;" type="text" value="868.1"/>	5-SF7BW125	0-SF12BW125
<input checked="" type="checkbox"/>	1	<input style="width: 80px;" type="text" value="868.3"/>	5-SF7BW125	0-SF12BW125
<input checked="" type="checkbox"/>	2	<input style="width: 80px;" type="text" value="868.5"/>	5-SF7BW125	0-SF12BW125
<input type="checkbox"/>	3	<input style="width: 80px;" type="text" value="0"/>	5-SF7BW125	0-SF12BW125
<input type="checkbox"/>	4	<input style="width: 80px;" type="text" value="0"/>	5-SF7BW125	0-SF12BW125
<input type="checkbox"/>	5	<input style="width: 80px;" type="text" value="0"/>	5-SF7BW125	0-SF12BW125
<input type="checkbox"/>	6	<input style="width: 80px;" type="text" value="0"/>	5-SF7BW125	0-SF12BW125
<input type="checkbox"/>	7	<input style="width: 80px;" type="text" value="0"/>	5-SF7BW125	0-SF12BW125

If frequency is one of CN470/AU915/US915, you can enter the index of the channel that you want to enable in the input box, making them separated by commas.

Examples:

1, 40: Enabling Channel 1 and Channel 40

1-40: Enabling Channel 1 to Channel 40

1-40, 60: Enabling Channel 1 to Channel 40 and Channel 60

All: Enabling all channels

Null: Indicates that all channels are disabled

Support Frequency : AU915

Enabled Channel Index: 0-71

Channel Index	Frequency/MHz	Channel Spacing/MHz	BW/kHz
0 - 15	915.2 - 918.2	0.2	125
16 - 31	918.4 - 921.4	0.2	125
32 - 47	921.6 - 924.6	0.2	125
48 - 63	924.8 - 927.8	0.2	125
64 - 71	915.9 - 927.1	1.6	500

4.2.2 Cellular & Application Settings (Cellular Version Only)

Cellular settings is used for configuring the transmission parameters in cellular network and is only applied to UC300 cellular version.

Cellular Settings:

Go to "**General -> Basic**" to configure basic cellular settings.

Cellular Settings

Network Type: Auto

PIN Code:

User:

Password:

APN:

SMS Center Number: ?

SMS Data Coding Scheme: 7 BIT

NTP Server: www.ntp.org

Change Password:

Save

Parameters	Description
Network Type	Select from "Auto", "4G Only", "3G Only", and "2G Only". Auto: connect to the network with the strongest signal automatically. 4G Only: connect to 4G network only. And so on.
PIN Code	Enter a 4-8 characters PIN code to unlock the SIM.
User	Enter the username for cellular dial-up connection provided by local ISP. The max length is 31 characters.
Password	Enter the password for cellular dial-up connection provided by local ISP. The max length is 31 characters.
APN	Enter the Access Point Name for cellular dial-up connection provided by local ISP. The max length is 31 characters.
SMS Center Number	Enter the local SMS center number for storing, forwarding, converting and delivering SMS message. This is required if you need to use SMS control or reporting feature.
SMS Data Coding Scheme	7 Bit: standard GSM message coding for most common letters and symbols, can contain up to 160 characters. 8 Bit: suit for multimedia messages, can contain up to 140 characters.

	UCS-2: send Unicode characters and suit for more languages like Chinese, Korean and Arabic, can contain up to 70 characters.
NTP Server	Enter the NTP Server's IP address or domain name. After registered to network, the device will sync the device time from this server. Default: www.ntp.org
Change Password	Change the password to login ToolBox and SMS password validation.

Application Settings:

Go to **"Application -> Application"** to configure the settings to send data to corresponding servers. About the MQTT topics, please refer to the **UC300 Cellular Communication Protocol**.

Parameters	Description
Application Mode	Select from "Milesight IoT Cloud", "AWS", "TCP", "UDP", and "MQTT".
Reporting Interval (s)	The interval of reporting interface data. Default: 1800s, Range: 10-64800s Note: for Milesight IoT Cloud mode, the reporting interval should be configured on the cloud webpage.
Milesight IoT Cloud	
Keep Alive Interval (s)	After connected, the device will send heartbeat packet regularly to keep alive. Default: 200 s, Range: 1-3600 s
AWS	
Server Address	Fill in the AWS server domain name which the data sends to.
Keep Alive Interval	After connected, the device will send heartbeat packet regularly to keep alive.

(s)	Default: 200 s, Range: 1-3600 s
CA File	Import the CA.crt file.
Client Certificate	Import the client certificate.
Client Key	Import the client key.

TCP/UDP

Description	After TCP/UDP connection established, the device will send one package including the description to identify the device. The max length is 32 characters.
Keep Alive Interval (s)	For TCP connection, the device will send heartbeat packet regularly to keep alive. Default: 60 s, Range: 60-7200 s
Custom Heartbeat Mode	After enabled, the device will send custom heartbeat packets to TCP server.
Custom Content	Customize the heartbeat packet content. The max length is 32 characters.
Heart Interval (s)	The device will send custom heartbeat packet regularly. Default: 30 s, Range: 30-3600 s
Require Response	After the device send custom heartbeat packet, it needs a specific response from server.
Response Content	Customize the server reply content after receiving custom heartbeat packets. The max length is 32 characters.
Server Address	Fill in the TCP/UDP server address (IP/domain name).
Server Port	Fill in the TCP/UDP server port. Range: 1-65535. Note: The server address and port should not exactly the same as the TCP/UDP settings on "RS232" page.
Status	Show the connection status between the device and the server.

MQTT

Broker Address	Fill in MQTT broker address to receive data.
Port	Fill in MQTT broker port to receive data.
Client ID	Client ID is the unique identity of the client to the server, it must be unique when all clients are connected to the same server.
Keep Alive Interval (s)	After the client is connected with the server, the client will send heartbeat packet regularly to keep alive. Default: 60 s, Range: 1-65535 s

User Credentials

Enable	Enable user credentials.
Username	The username used for connecting to MQTT broker.

Password	The password used for connecting to MQTT broker.
TLS	
Enable	Enable the TLS encryption in MQTT communication.
Protocol	It's fixed as TLS v1.2.
CA File	Import the CA.crt file.
Client Certificate	Import the client certificate.
Client Key	Import the client key.

4.2.3 SMS Settings (Cellular Version Only)

UC300 cellular version supports SMS control and SMS report. Before that, ensure the device has registered to cellular network and SMS Center Number is typed in "General -> Basic" settings. About the SMS control commands and report contents, please refer to the **UC300 Cellular Communication Protocol**.

SMS Control	<input checked="" type="checkbox"/>
Control Center Number 1	<input type="text"/>
Control Center Number 2	<input type="text"/>
Success Confirmation	<input checked="" type="checkbox"/>
Failure Confirmation	<input type="checkbox"/>

SMS Control	
Parameters	Description
Enable	Enable to allow users to send SMS to control the device.
Control Center Number	The number used to control this device. 2 control numbers can be added at most.
Success Confirmation	After control success, the device will send success reply to the control center number.
Failure Confirmation	After control failure, the device will send failure reply to control center number.

SMS Report	<input checked="" type="checkbox"/>
Any Change Report	<input type="checkbox"/>
Regular Report Interval	<input checked="" type="checkbox"/> <input type="text" value="720"/> min
SMS Messaging Protocol	<input type="button" value="?"/> <input type="text" value="General"/>
Number 1	<input type="text"/>
Number 2	<input type="text"/>
Number 3	<input type="text"/>
Number 4	<input type="text"/>
Number 5	<input type="text"/>
Number 6	<input type="text"/>

SMS Report

Parameters	Description
Enable	Enable to allow device to report device DI/DO status via SMS.
Any Change Report	When any of DI/DO interfaces' status changed, the device will send the current status via SMS.
Regular Report Interval	Report the time, signal, network type and data interface status/values of device regularly via SMS. Default: 720 mins, Range: 1-1440 mins.
SMS Messaging Protocol	Select the SMS messaging protocol. It's General by default. General: send SMS as general string format. UCP: send SMS as hex format, you can decode it referring to UC300 Communication Protocol document.
Number	Reports SMS to these phone numbers. 6 numbers can be added at most.

4.3 Data Interface Settings

4.3.1 Basic Settings

LoRaWAN Version:

Device ID	<input type="text" value="6445C06166800001"/>
Reporting Interval(min)	<input type="text" value="20"/>
LoRa D2D	<input type="checkbox"/>
D2D Key	<input type="text" value="*****"/>
Change Password	<input type="checkbox"/>

Parameters	Description
Device ID	Show the SN of the device.
Reporting Interval	Reporting interval of transmitting data to network server.Default: 20mins Note: RS232 transmission will not follow the reporting interval.
LoRa D2D	See details on chapter 4.5 .
Change Password	Change the password to login Toolbox.

Cellular Version:

See cellular setting in [chapter 4.2.2](#).

4.3.2 Digital Input/Pulse Settings

UC300 supports 4 digital inputs and every input can work as either digital input mode to detect high/low level or pulse counter to record counting values. When working as digital input, UC300 will upload the data according to reporting interval or when status changes.

Interface Name	DI_1
Enable	<input checked="" type="checkbox"/>
Interface Type	<input type="text" value="Digital Input"/>
Status	<input type="text" value=""/> <input checked="" type="checkbox"/> <input type="button" value="Fetch"/>

Interface Name	DI_2
Enable	<input checked="" type="checkbox"/>
Interface Type	<input type="text" value="Counter"/>
Digital Filter	<input checked="" type="checkbox"/> <input type="button" value="?"/>
Counter Values	<input type="text" value=""/> <input checked="" type="checkbox"/> <input type="button" value="Refresh"/> <input type="button" value="Start"/> <input type="button" value="Clear"/>

Parameters	Description
Enable	Enable digital input to detect status and upload the data.
Digital Input	
Fetch	Click to get the current input status.
Counter	
Digital Filter	It's recommended to enable when pulse period is greater than 250 us.
Start/Stop	Click to start/stop counting. Note that UC300 will send non-changeable counting values if you do not click "Start".
Refresh	Refresh to get latest counter values.
Clear	Count the value from 0.

Note: the counting value will lose if UC300 loses the power.

4.3.3 Digital Output Settings

UC300 supports 2 digital outputs to control the devices.

Interface Name: DO_1

Enable:

When Power is Restored, DO: Return to Previous Working State

Status: Closed

Interface Name: DO_2

Enable:

When Power is Restored, DO: Turn to Normally Closed

Status: Open

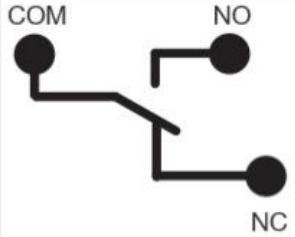
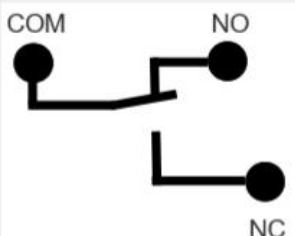
Parameters	Description
Enable	Enable the digital output to control the device and upload changed status.
When Power is Restored, DO	After the device power is restored, the DO status will return to normally closed or normally open according to this parameter.
Fetch	Click to get the current output status.
Switch	Click to change the DO status.

4.3.4 RS485 Settings

UC300 has one RS485 port for Modbus RTU device connection.

1. Connect RS485 device to RS485 port.
2. Go to **"General -> RS485"** to enable RS485 and configure serial port settings. Serial port

settings should be the **same** as the RS485 terminal devices.

Enable	<input checked="" type="checkbox"/>
Stop Bit	1 bits
Data Bit	8 bits
Parity	None
Baud Rate	9600
Execution Interval (ms)	50
Max Resp Time (ms)	500
Max Retry Times	3
Modbus RS485 bridge LoRaWAN	<input checked="" type="checkbox"/>
Port	0

Parameters	Description
Enable	Allow the device to collect RS485 data and upload the data.
Stop Bit	1 bit/2 bit are available.
Data Bit	8 bit is available.
Parity	None, Odd and Even are available.
Baud Rate	1200/2400/4800/9600/19200/38400/57600/115200 are available.
Execution Interval (ms)	The execution interval between each Modbus channel command.
Max Resp Time (ms)	The maximum response time that the UC300 waits for the reply to the command. If it does not get a response after the max response time, it is determined that the command has timed out.
Max Retry Time (ms)	Set the maximum retry times after device fails to read data from RS485 terminal devices.
Modbus RS485 bridge LoRaWAN (LoRaWAN® Version Only)	If this mode is enabled, the device will transmit Modbus RTU commands from network server to RS485 terminal devices transparently and send Modbus reply originally back to the network server. Port: Select from 2-84, 86-223.

3. Click  to add Modbus channels, then save configurations.

Channel Settings Fetch All

Channel ID	Name	Slave ID	Address	Quantity	Type	Byte Order	Sign	Value	
1	1	1	0	1	Input Register(INT16)	AB	<input type="checkbox"/>		✓ Fetch
2	test	255	535	2	Coil		<input checked="" type="checkbox"/>		✓ Fetch

Save Up to 16 channels

Parameters	Description
Channel ID	Select the channel ID you want to configure from 16 channels.
Name	Customize the name to identify every Modbus channel.
Slave ID	Set Modbus slave ID of terminal device.
Address	The starting address for reading.
Quantity	Set read how many digits from starting address. For LoRaWAN [®] version, it fixes to 1; for cellular version, it can be set as 1 to 4.
Type	Select data type of Modbus channels.
Byte Order	Set the Modbus data reading order if you configure the type as Input register or holding register. INT32/Float: ABCD, CDBA, BADC, DCBA INT16: AB, BA
Sign	The tick indicates that the value has a plus or minus sign.
Fetch	After click, UC300 will send Modbus read command to test if it can read correct values. Example: as this setting, the device will send command: 01 03 00 00 00 01 84 0A

Channel Settings

Channel ID	Name	Slave ID	Address	Quantity	Type	Byte Order	Sign	Value	
1	temperature	1	0	1	Holding Register(INT16)	AB	<input type="checkbox"/>		✓ Fetch

4. Click "Fetch" to check if UC300 can read correct data from terminal devices.

4	C	1	0	1	Input Register(INT16)	AB	<input type="checkbox"/>	21	✓ Fetch
---	---	---	---	---	-----------------------	----	--------------------------	----	---------

Note: Do not click "Fetch" frequently since response time to reply is differ for every terminal device.

4.3.5 RS232 Settings

UC300 has one RS232 interface for transparent communication. Usually it will use different tunnels from other data interfaces to communicate with server.

Enable	<input checked="" type="checkbox"/>
Baud Rate	9600
Stop Bit	1 bits
Data Bit	8 bits
Parity	None
Packet Length (byte)	256
Serial Frame Interval (ms)	100
Port	86

Protocol	TCP
Keep Alive Interval(s)	60
Packet Length (byte)	256
Serial Frame Interval (ms)	100
Reconnection Interval(s)	10
Register String	
Destination IP Address	
Server Address	Server Port
	Status

Parameters	Description
Baud Rate	1200/2400/4800/9600/19200/38400/57600/115200 are available.
Data Bit	8 bit is available.
Stop Bit	1 bit/2 bit are available.
Parity	None, Odd and Oven are available.
Packet Length (byte)	When the device receives RS232 data up to this length, it will fragment it as a single packet and send to network server.
Serial Frame	The interval that the device sends out real serial data stored in the buffer

Interval (ms)	area to public network. The range is 10-65535 milliseconds. Note: data will be sent out when real serial data size reaches the preset packet size, even though it's within the serial frame interval.
LoRaWAN Version	
Port	Send or receive RS232 data from this port, this port should different from the Application port. Range: 2-84, 86-223.
Cellular Version	
Protocol	Select "TCP" or "UDP" protocol.
Keep Alive Interval (s)	For TCP connection, the device will send heartbeat packet regularly to keep alive. Default: 60s, Range: 60-7200 s
Reconnect Interval (s)	After connection failure, the device will reconnect to the TCP server after the preset interval. Default:10 s, Range: 10-60 s.
Register String	After TCP/UDP connection established, the device will send the register string to identify the device. The max length is 32 characters.
Server Address	Fill in the TCP or UDP server address (IP/domain name).
Server Port	Fill in the TCP or UDP server port. Range: 1-65535. Note: The server address and port should not exactly the same as the TCP/UDP settings on "Application Mode".
Status	Show the connection status between the device and the TCP server.

4.3.6 Analog/PT100 Settings

UC300 has two 4-20mA analog inputs, two 0-10V analog inputs and two PT100 inputs for analog device connection. After wirings, you can click "Fetch" to check if the value is correct.

PT100 Note:

- 1) The temperature unit in the reporting package is fixed as °C.
- 2) Please modify the command IF condition threshold settings if you change the temperature unit.

Interface Name	? 4-20mA_1
Enable	<input checked="" type="checkbox"/>
Osh	<input type="text" value="20.00"/>
Osl	<input type="text" value="4.00"/>
Unit	<input type="text" value="mA"/>
Status	<input type="text" value=""/> <input checked="" type="checkbox"/> <input type="button" value="Fetch"/>

Interface Name	? 0-10V_1
Enable	<input checked="" type="checkbox"/>
Osh	<input type="text" value="10.00"/>
Osl	<input type="text" value="0.00"/>
Unit	<input type="text" value="V"/>
Status	<input type="text" value="0.00V"/> <input checked="" type="checkbox"/> <input type="button" value="Fetch"/>

Interface Name	PT100_1
Enable	<input checked="" type="checkbox"/>
Unit	<input type="text" value="°C"/>
Status	<input type="text" value=""/> <input checked="" type="checkbox"/> <input type="button" value="Fetch"/>

4.4 IF-THEN Command

UC300 supports configuring locally IF-THEN commands to do some actions automatically even without network connection. One device can be added 16 commands at most.

1. Go to "Command" page, click "Edit" to add commands.

Settings >

ID	Configuration	Edit	Delete
1	If pt100(pt100_2) is above 35.00 continued for 0s. then do_1 will be normally open in 0s and it will last for 0s .		
2			
3			
4			
5			

Configuration for command NO.2

If

Is continued for

Set lockout time

2. Set a IF condition based on the terminal device data or UC300 device status.

Condition	Description
Time	Set the time condition. The device time will be synced once after joining/registering to network, you can also sync the time manually on "Status" page.
Digital Input	When UC300 device detects the DI as a specific status. Is continued for: the DI changed status should last for some time. Set lockout time: after the lockout time, UC300 will detect if DI status matches the condition. 0 means this IF condition will only be detected once.

Counter	When pulse counter reaches a specific value. This only works when DI works as counter mode.
Channel/4-20m A/0-10V/PT100	When the value reaches any threshold. Is continued for: the analog value should last for some time. Set lockout time: after the lockout time, UC300 device will detect if analog value matches the condition. 0 means this IF condition will only be detected once. Note: for UC300 cellular version, if this Modbus channel quantity is more than 1, this condition will only judge the first value.
Received a message	When UC300 device receive a specific message from server.
The Device Restarts	Reboot the device.
Received a D2D control command	This only works with UC300 LoRaWAN® version and the LoRa D2D feature is enabled. See details on chapter 4.5 .
The signal strength is weak	When UC300 cellular signal is lower than 10 asu, this only works with UC300 cellular version.

3. Set THEN action according to your request. You can add at most 3 actions in one command.

Action	Description
Send a custom message	Send a custom message to the server.
Output Trigger	DO can be set to normally open/normally closed/change status. Delay Time: this action will trigger after a specific time; Duration: the output status will last for a specific time, 0 means permanent.
Restart the Device	Reboot the device.
Send a D2D control command	This only works with UC300 LoRaWAN® version and the LoRa D2D feature is enabled. See details on chapter 4.5 .
Send a Modbus command via RS485 interface	This only works with UC300 LoRaWAN® version and the LoRa D2D feature is enabled. See details on chapter 4.5 .
Send a device status message	This only works with UC300 cellular version and the SMS Report feature is enabled.

via SMS

4.5 LoRa D2D Settings (LoRaWAN Version Only)

LoRa D2D protocol is developed by Milesight and used for setting up transmission among Milesight devices without gateway. When the LoRa D2D setting is enabled, UC300 can work as a LoRa D2D controller to send control commands to other devices or work as a LoRa D2D agent to receive commands to trigger the DO or RS485 devices.

1. Go to **"General -> Basic"** page, enable LoRa D2D feature, define a unique LoRa D2D key which is the same as LoRa D2D controller or agent devices. (Default LoRa D2D Key: 5572404C696E6B4C6F52613230313823)

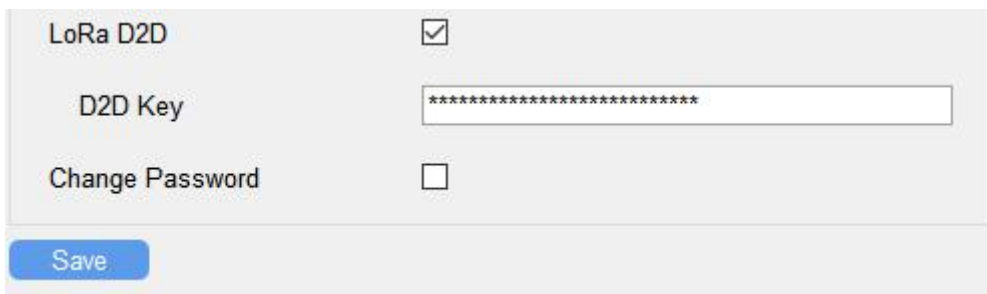

LoRa D2D	<input checked="" type="checkbox"/>
D2D Key	*****
Change Password	<input type="checkbox"/>

Save

2. Go to **"LoRaWAN Settings -> Basic"** to configure the RX2 datarate and RX2 frequency. When UC300 works as LoRa D2D controller, it will send commands as RX2 settings.

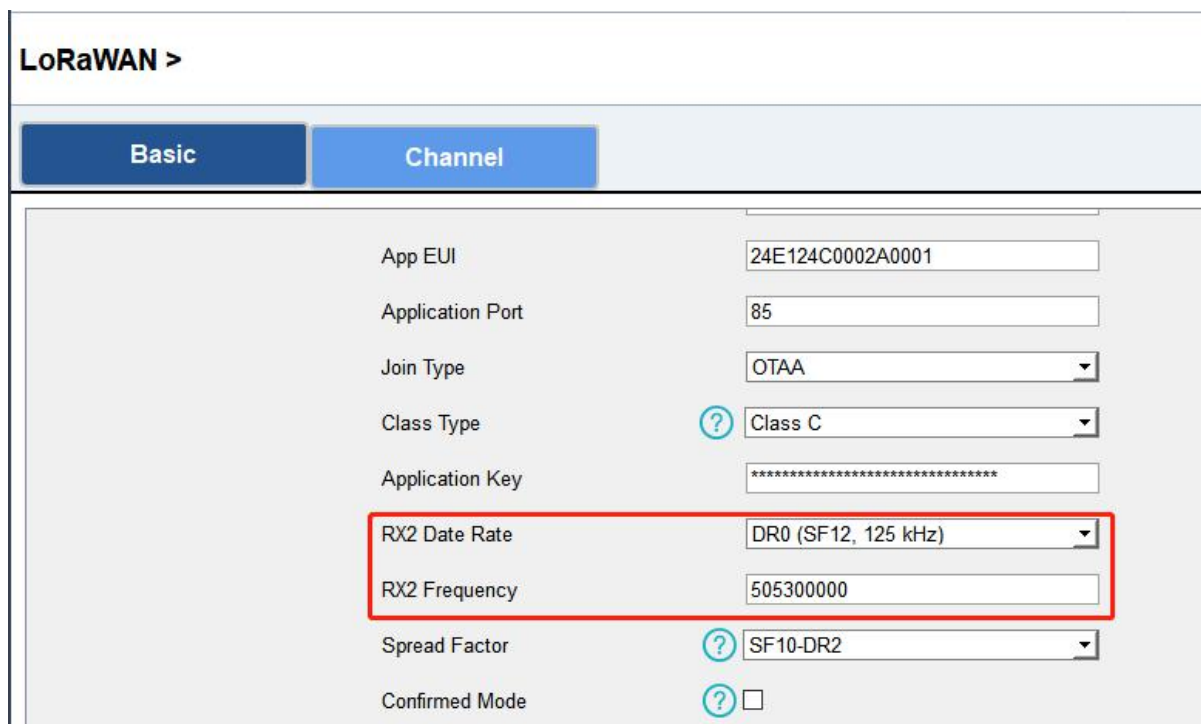

LoRaWAN >

Basic Channel

App EUI	24E124C0002A0001
Application Port	85
Join Type	OTAA
Class Type	Class C
Application Key	*****
RX2 Date Rate	DR0 (SF12, 125 kHz)
RX2 Frequency	505300000
Spread Factor	SF10-DR2
Confirmed Mode	<input type="checkbox"/>

3. Go to **"Command"** page to set corresponding operations.

When DI triggers, UC300 can work as LoRa D2D controller to send control command to control

the LoRa D2D agent device. The command should be a 2-byte hexadecimal number.

Configuration for command NO.1

If Digital Input

DI 1 + ×

goes active (rising edge-triggered)

Is continued for 0 s

Set lockout time ?

Then Send a D2D control command +

Content is 0001

When UC300 receives a LoRa D2D command, it can work as a LoRa D2D agent to trigger the DO or send Modbus command to RS485 terminal devices.

Configuration for command NO.1

If Received a D2D control command

Containing f001

Then DO 1 +

Will be normally open

Delay Time 0 s Duration 0 s

Configuration for command NO.1

If Received a D2D control command ▼

Containing f001

Then Send a Modbus command via the RS485 interfac ▼ (+)

Content is Only hexadecimal numbers are allowed

Note: When this feature is enabled and the command is triggered, the device will not send data to LoRaWAN® network server.

4.6 Maintenance

4.6.1 Upgrade

UC300 supports upgrade locally via ToolBox software.

1. Download firmware from www.milesight-iot.com to your PC.
2. Go to **"Maintenance -> Upgrade"**, click **"Browse"** to import firmware and upgrade the device.

You can also click **"Up to Date"** to search for the latest firmware of the device and upgrade.

Note: Any operation on ToolBox is not allowed during upgrading, otherwise the upgrading will be interrupted, or even the device will break down.

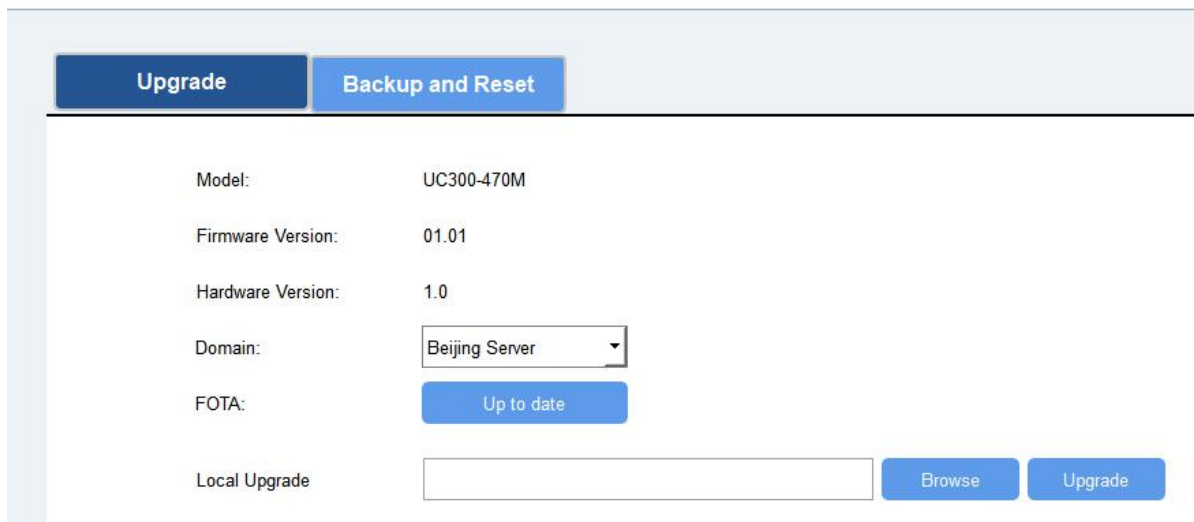
Maintenance >

The screenshot shows the 'Upgrade' tab selected in the 'Maintenance >' section. The page displays the following information and controls:

- Model:** UC300-470M
- Firmware Version:** 01.01
- Hardware Version:** 1.0
- Domain:** Beijing Server (dropdown menu)
- FOTA:** Up to date (button)
- Local Upgrade:** An empty text input field, a 'Browse' button, and an 'Upgrade' button.

4.6.2 Backup

UC300 devices support configuration backup for easy and quick device configuration in bulk.

Backup is allowed only for devices with the same model and LoRa frequency band.

1. Go to **"Maintenance -> Backup and Reset"**, click "Export" to save current configuration as json format backup file.
2. Click "Browse" to select backup file, then click "Import" to import the configurations.

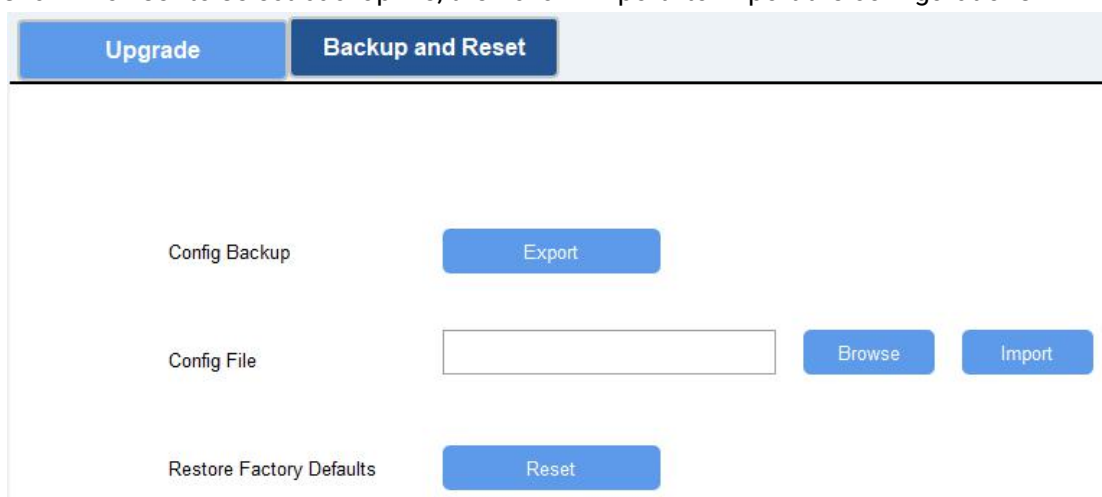

The screenshot shows the 'Backup and Reset' tab selected in the 'Maintenance >' section. The page displays the following information and controls:

- Config Backup:** Export (button)
- Config File:** An empty text input field, a 'Browse' button, and an 'Import' button.
- Restore Factory Defaults:** Reset (button)

4.6.3 Reset to Factory Default

Please select one of following methods to reset device:

Via Hardware: Open the case of UC300, hold on the reset button for more than 10 s until SYS LED blinks.

Via ToolBox Software: Go to **"Maintenance -> Backup and Reset"** to click "Reset".

Upgrade Backup and Reset

Config Backup	<input type="button" value="Export"/>		
Config File	<input type="text"/>	<input type="button" value="Browse"/>	<input type="button" value="Import"/>
Restore Factory Defaults	<input type="button" value="Reset"/>		

5. Device Payload

For UC300 LoRaWAN® version, please refer to the ***UC300 LoRaWAN Communication Protocol***;
For UC300 cellular version, please refer to the ***UC300 Cellular Communication Protocol***; for
decoders of Milesight IoT products please click [here](#).

-END-