



# Temperature Sensor

TS201

User Guide

# Contents

<b>Chapter 1. Preface</b> .....	<b>4</b>
<b>Chapter 2. Product Introduction</b> .....	<b>6</b>
Overview.....	6
Features.....	6
<b>Chapter 3. Hardware Introduction</b> .....	<b>7</b>
Packing List.....	7
Hardware Overview.....	7
Power Button and LED Patterns.....	7
Dimensions(mm).....	8
<b>Chapter 4. Quick Start</b> .....	<b>10</b>
Power On.....	10
Access the Sensor via NFC.....	10
Configure the Network Setting.....	11
<b>Chapter 5. Operation Guide</b> .....	<b>13</b>
LoRaWAN <sup>®</sup> Settings.....	13
Time Synchronization.....	15
General Settings.....	17
Calibration Settings.....	19
Threshold Settings.....	20
Milesight D2D Settings.....	22
Sensor Data Transmission Settings.....	22
Milesight D2D Controller.....	23
Maintenance.....	25
Upgrade.....	25
Backup and Restore.....	26
Reset to Factory Default.....	28
<b>Chapter 6. Installation</b> .....	<b>30</b>

Device Installation.....	30
Thermal Buffer Bottle (Alternative).....	30
<b>Chapter 7. Battery Replacing.....</b>	<b>32</b>
<b>Chapter 8. Uplink and Downlink.....</b>	<b>33</b>
Overview.....	33
Uplink Data.....	33
Basic Information.....	33
Periodic Report.....	34
Alarm Report.....	35
Historical Data.....	37
Downlink Command.....	38
Device Configuration Command.....	38
Device Configuration Enquiry.....	44
Historical Data Enquiry.....	47
<b>Chapter 9. Services.....</b>	<b>50</b>

# Chapter 1. Preface

## Copyright Statement

This guide may not be reproduced in any form or by any means to create any derivative such as translation, transformation, or adaptation without the prior written permission of Xiamen Milesight IoT Co., Ltd (Hereinafter referred to as Milesight).

*Milesight* reserves the right to change this guide and the specifications without prior notice. The latest specifications and user documentation for all Milesight products are available on our official website <http://www.milesight.com>

## Safety Instruction

These instructions are intended to ensure that user can use the product correctly to avoid danger or property loss. Milesight will not shoulder responsibility for any loss or damage resulting from not following the instructions of this operating guide.



### **CAUTION:**

Injury or equipment damage may be caused if any of these cautions are neglected.

- The device must not be disassembled or remodeled in any way.
- To ensure the security of your device, please change the device password during the initial configuration. The default password is 123456.
- The device is not intended to be used as a reference sensor, and Milesight will not should responsibility for any damage which may result from inaccurate readings.
- Do not place the device close to objects with naked flames.
- Do not place the device where the temperature is below/above the operating range.
- Make sure electronic components do not drop out of the enclosure while opening.
- When installing the battery, please install it accurately, and do not install the inverse or wrong model.
- The device must never be subjected to shocks or impacts.

## Revision History

Release Date	Version	Description
May 30, 2024	V1.0	Initial version
Aug. 17, 2024	V1.1	Add DS18B20 probe ID report and enquiry command.
April 29, 2025	V2.0	Update based on hardware v2.x: Add external button and support TH Version.

# Chapter 2. Product Introduction

## Overview

Milesight TS201 is a compact temperature and humidity sensor. It is equipped with high-precision sensors and an IP67 waterproof design, making it applicable for accurate temperature data detection in various harsh environments. With the low power consumption technology, TS201 can maintain a long operational life with its internal battery. Combining with Milesight LoRaWAN<sup>®</sup> gateway and Milesight Development Platform solution, users can manage all sensor data remotely and visually.

TS201 is widely used for temperature and humidity monitoring applications like food processing, cold chain storage of food or medicine, etc.

## Features

- Equipped with a DS18B20 temperature probe or a TH (temperature - humidity) probe
- Detachable probe design for self-calibration
- IP67 waterproof with specialized battery compartment design , making it suitable for harsh environment
- Flexible design for various mounting options
- EN12830 certified for cold-chain applications
- Store 4,000 historical records locally and support retransmission to prevent data loss
- Equipped with NFC for quick and easy configuration
- Function effectively with standard LoRaWAN<sup>®</sup> gateways and network servers
- Compatible with Milesight Development Platform
- Supports Milesight D2D protocol for ultra-low latency and direct control without gateways
- Support Firmware Update Over the Air (FUOTA) feature

# Chapter 3. Hardware Introduction

## Packing List



1 × TS201 Device



1 × Temperature (Humidity) Probe

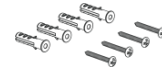

4 × Wall Screw Mounting Kits



1 × Quick Guide



1 × Warranty Card



1 × Glass Bead Thermal Buffer Bottle Kit (Optional)



### Note:

If any of the above items is missing or damaged, please contact your sales representative.

## Hardware Overview

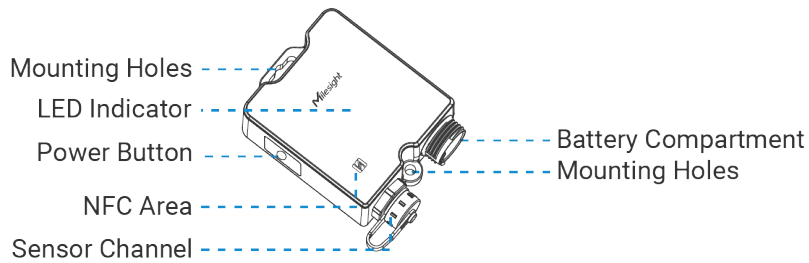

## Power Button and LED Patterns

Function	Action	LED Indicator
Power On	Press and hold the button for more than 3 seconds.	Off → On
Power Off		On → Off

Function	Action	LED Indicator
Network Status	Quick press the power button once	De-activated: Red light on Activated: Green light on
Probe Connection Detection	Connect the temperature (humidity) probe while the device is off, then power it on after connection	Failure: Red light stays on for 3s Success: Green light stays on for 3s
Data Collection and Reporting	Quick press the power button twice	LoRaWAN <sup>®</sup> De-activated: Red light blinks twice LoRaWAN <sup>®</sup> Activated: Green light blinks twice
Threshold Alarm	Collected data exceeds the set threshold	Red light blinks Slowly
Reset to Factory Default	Create a short circuit with probe 5 and 3 for 10s	Green light blinks quickly

### Dimensions(mm)

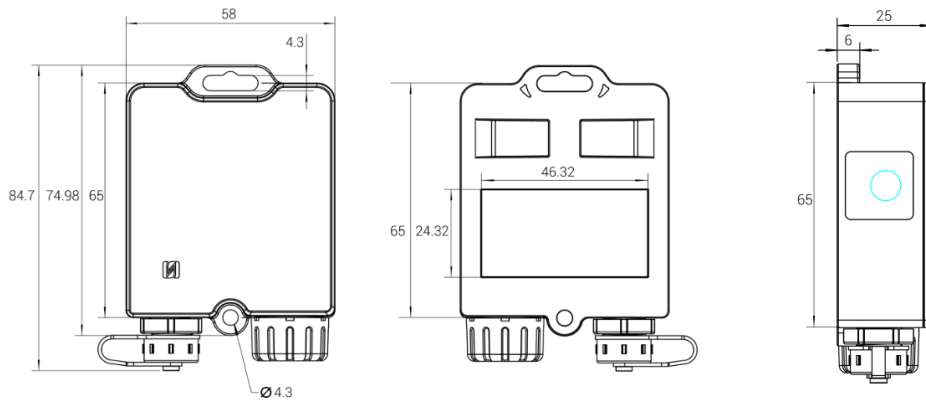

### Probe:

Temperature Version

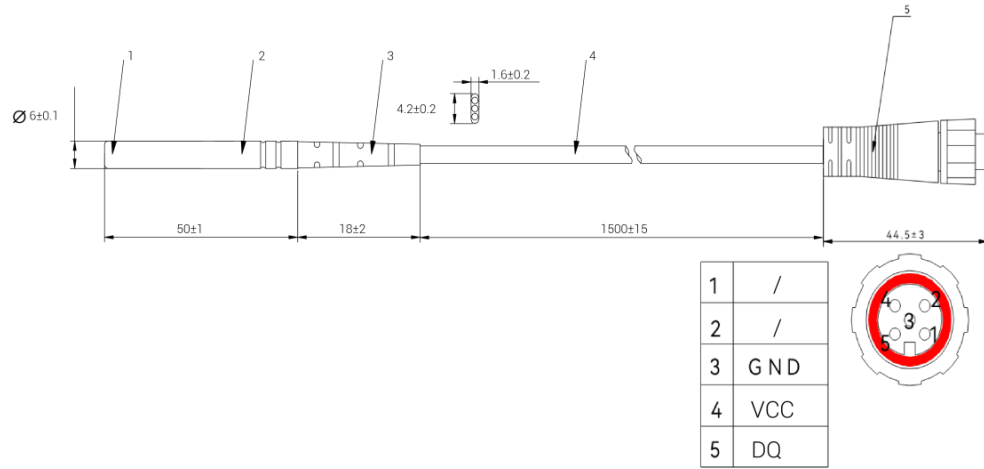

TH Version

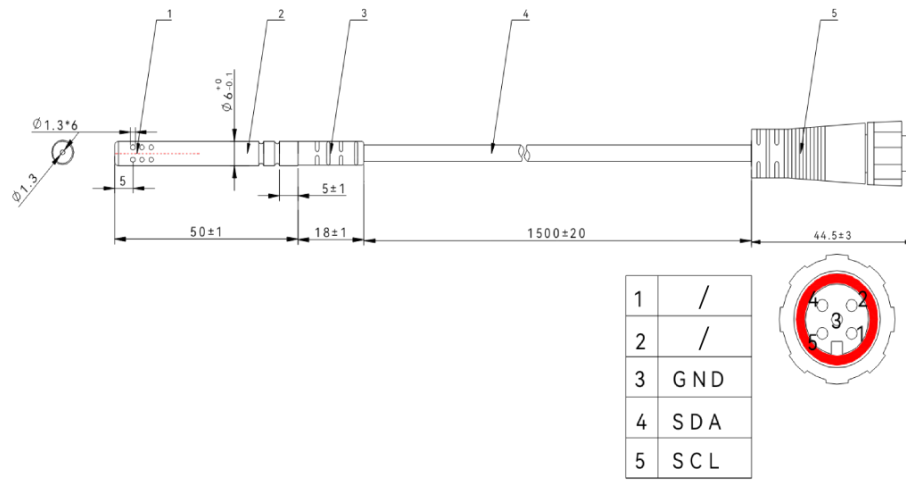



**Note:**

- Ensure the location of smartphone NFC area and it's recommended to take off phone case.
- If the smart phone fails to read/write configurations via NFC, keep the phone away and back to try again.
- The default device password is 123456. Please change a new password for security.



## Configure the Network Setting

1. Go to **Network** settings page, select the join type as OTAA or ABP as required.

**Note:**

OTAA mode is required if you connect device to Milesight IoT Cloud or Milesight Development Platform.

2. Select supported frequency the same as LoRaWAN<sup>®</sup> gateway.

**Note:**

Set the channel index as 8-15 for US915 or AU915 if using default settings of Milesight gateways.

Device Network

LoRaWAN

\* Support Frequency

US915

Enable Channel Index ⓘ

8-15



Index	Frequency/MHz ⓘ
0 - 15	902.3 - 905.3
16 - 31	905.5 - 908.5
32 - 47	908.7 - 911.7
48 - 63	911.9 - 914.9
64 - 71	903 - 914.2



3. Keep other settings by default and click **Write** to save the settings.

# Chapter 5. Operation Guide

## LoRaWAN<sup>®</sup> Settings

This chapter describes the LoRaWAN<sup>®</sup> network settings of device.

Parameter	Description
Device EUI	Unique ID of the device which can be found on the device.  <b>Note:</b> please contact sales for device EUI list if you have many units.
App EUI	The default App EUI (join EUI) is 24E124C0002A0001.
Application Port	The port used for sending and receiving data, the default port is 85.
LoRaWAN <sup>®</sup> Version	V1.0.2 and V1.0.3 are available.
Work Mode	It's fixed as Class A.
Confirmed Mode	If the device does not receive ACK packet from network server, it will resend data once.
Join Type	OTAA and ABP mode are available.  <b>Note:</b> It's necessary to select OTAA mode if connecting device to Milesight Development Platform.
Application Key	Appkey for OTAA mode, default value: "Device EUI" + "Device EUI" (since Q4 of 2025). Example: 24e124123456789024e1241234567890

Parameter	Description
	<div data-bbox="511 289 1416 625" style="background-color: #e6f2ff; padding: 10px;">  <b>Note:</b> <ul style="list-style-type: none"> <li>The default value of earlier devices is 5572404C696E6B4C6F52613230313823.</li> <li>Please contact sales before purchase if you require random App Keys.</li> </ul> </div>
Network Session Key	Nwkskey for ABP mode, the default is 5572404C696E6B4C6F52613230313823.
Application Session Key	Appskey for ABP mode, the default is 5572404C696E6B4C6F52613230313823.
Device Address	DevAddr for ABP mode, default is the 5 <sup>th</sup> to 12 <sup>th</sup> digits of SN.
Rejoin Mode	<p>Reporting interval ≤ 35 mins: the device will send a specific number of Link-CheckReq MAC packets to the network server every reporting interval or every double reporting interval to validate connectivity; If there is no response, the device will re-join the network.</p> <p>Reporting interval &gt; 35 mins: the device will send a specific number of Link-CheckReq MAC packets to the network server every reporting interval to validate connectivity; If there is no response, the device will re-join the network.</p> <div data-bbox="511 1354 1416 1640" style="background-color: #e6f2ff; padding: 10px;">  <b>Note:</b> <ol style="list-style-type: none"> <li>1. Only OTAA mode supports rejoin mode.</li> <li>2. The actual sending number is <b>Set the number of packets sent</b> +1.</li> </ol> </div>
Supported Frequency	<p>Enable or disable the frequency to send uplinks. If frequency is one of CN470/AU915/US915, enter the index of the channel to enable in the input box, making them separated by commas.</p> <p><b>Examples:</b></p>

Parameter	Description
	1, 40: Enabling Channel 1 and Channel 40 1-40: Enabling Channel 1 to Channel 40 1-40, 60: Enabling Channel 1 to Channel 40 and Channel 60 All: Enabling all channels Null: Indicate that all channels are disabled
ADR Mode	Enable or disable network server to adjust Spreading Factor, Bandwidth and Tx Power to optimize data rates, airtime and energy consumption in the network.
Spreading Factor	If ADR mode is disabled, the device will send uplink data following this SF parameter. The higher the spreading factor, the longer the transmission distance, the slower the transmission speed and the more the consumption.
Tx Power	Tx power (transmit power) refers to the strength of the outgoing signal transmitted by the device. This is defined by LoRa alliance.
RX2 Data Rate	RX2 data rate to receive downlinks or send D2D commands.
RX2 Frequency	RX2 frequency to receive downlinks or send D2D commands. Unit: Hz

## Time Synchronization

This section describes how to sync the time of the device.

### Sync via ToolBox App

After reading the device via Milesight ToolBox App, sync the device time with time zone from the smart phone.

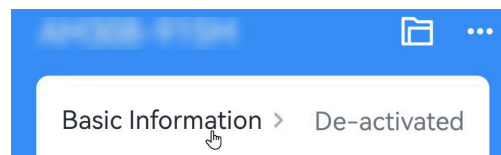

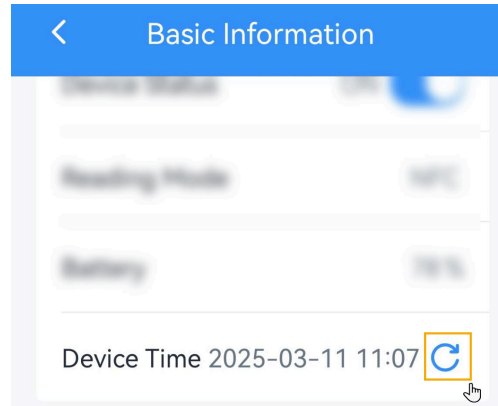

### Sync via Network Server

This requires to ensure the LoRaWAN<sup>®</sup> network server supports device time synchronization feature. Example: Milesight gateway embedded NS.

1. Set the LoRaWAN<sup>®</sup> version of the device to V1.0.3.
2. Connect the device to the network server. After joining the network, the device will send a DeviceTimeReq MAC command to enquire the time from network server.



#### Note:

- This only supports to get the time but not time zone. The time zone can be configured by ToolBox App or downlink command.
- The device will send the DeviceTimeReq command every 5 days since the last sync.

## General Settings

Reporting Interval(min)

Temperature Unit



---

Button Lock ⓘ

Data Storage ⓘ

Data Retransmission ⓘ

Change Password

Parameter	Description
Reporting Interval	Reporting interval of transmitting data to the network server. Range: 1~1440min; Default: 10mins
Temperature Unit	<p>Change the temperature unit displayed on the ToolBox.</p> <div style="background-color: #e6f2ff; padding: 10px; border-radius: 5px;"> <p> <b>Note:</b></p> <ol style="list-style-type: none"> <li>1. The temperature unit in the reporting package is fixed as Celsius(°C).</li> <li>2. Please modify the threshold settings if the unit is changed.</li> </ol> </div>
Button Lock	Enable to lock the power button feature: Turn Off, Collect and Report.
Data Storage	Disable or enable to store data locally. The stored data can be exported as CSV format file and saved to smartphone via ToolBox.

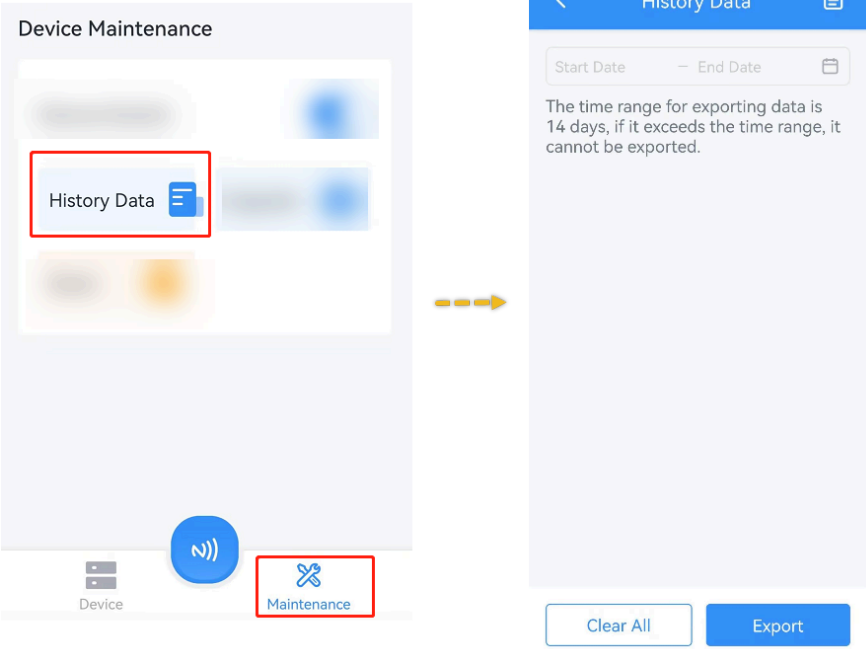
Parameter	Description
	 <p><b>Note:</b></p> <ol style="list-style-type: none"> <li>1. It is necessary to <a href="#">sync the time</a> to ensure the data is stored in correct time.</li> <li>2. The device will still store the data even the network status is de-activated.</li> <li>3. ToolBox App can only export the last 14 days' data at most.</li> </ol>
Data Retransmission	<p>Disable or enable data retransmission. When the device detects the network status is de-activated via <a href="#">Rejoin Mode</a>, the device will record a data lost time point and re-transmit the lost data after device re-connects to the network.</p>

Parameter	Description
	<p> <b>Note:</b></p> <ol style="list-style-type: none"> <li>1. This setting only takes effect when <a href="#">Data Storage</a> is enabled.</li> <li>2. If the device is rebooted or re-power when data retransmission is not completed, the device will re-send all retransmission data again after device is reconnected to the network.</li> <li>3. If the network is disconnected again during data retransmission, it will only send the latest disconnected data.</li> <li>4. The default report data retransmission interval is 600s, this can be changed via downlink command.</li> <li>5. The reported format of retransmission data will include timestamps and is different from periodic report data.</li> <li>6. This setting will increase the uplink frequencies and shorten the battery life.</li> </ol>
Change Password	Change the password for ToolBox App to write this device.

## Calibration Settings

### Temperature Calibration

Set the calibration value, the device will add calibration value to the current temperature value, then display and report the final value.

Temperature

Current Value(°C) <b>17.6</b>	Final Value(°C) <b>27.6</b>
----------------------------------	--------------------------------

Calibration Value(°C)

### Humidity Calibration

Set the calibration value, the device will add calibration value to the current humidity value and report the final value.

Humidity

Current Value(%)	Final Value(%)
<b>19.5</b>	<b>37.5</b>

Calibration Value(%)

## Threshold Settings

The device supports threshold alarms and shift threshold (change) alarms.

Temperature

Over / °C

Below / °C

---

Temperature Shift Threshold ⓘ

Temperature change greater than / °C

---

Humidity

Humidity Shift Threshold ⓘ

Collecting Interval(min)

10

Alarm Reporting Times

1

Alarm Dismiss Report ⓘ



Parameters	Description
Temperature	<p>When the temperature is over or below the threshold value, the device will report an alarm packet.</p> <div style="border: 1px solid #ccc; background-color: #e6f2ff; padding: 5px; margin-top: 10px;">  <b>Note:</b> when you change the temperature unit, please re-configure the threshold.         </div>
Temperature Shift (Change) Threshold	When this function is enabled, the device will report an alarm packet when the absolute value of the difference between the two collected values exceeds the set threshold.
Humidity	When the humidity is over or below the threshold value, the device will report alarm packets.
Humidity Shift(Change) Threshold	When this function is enabled, the device will report an alarm packet if the absolute difference between two consecutive readings exceeds the set threshold.
Collecting Interval	Set the interval of collecting data, the default interval is 1 min.
Alarm Reporting Times	Set the times of threshold alarm report, the default is 1.
Alarm Dismiss Report	After it is enabled, when the collected value changes from exceeding the threshold range to not exceeding the threshold range, an alarm dismiss packet will be reported.

## Milesight D2D Settings

Milesight D2D protocol is developed by Milesight and used for setting up transmission among Milesight devices without gateway.

### Sensor Data Transmission Settings

TS201 supports sending temperature and humidity sensor data to other Milesight devices directly.

1. Configure the RX2 datarate and RX2 frequency.



**Note:**

It is suggested to change the default values if there are many LoRaWAN<sup>®</sup> devices around.

Device
Network

LoRaWAN    D2D

---

Spreading Factor ⓘ

SF12-DR0

TXPower

TXPower0-16 dBm

---

RX2 Data Rate ⓘ

DR0 (SF12, 125 kHz)

RX2 Frequency ⓘ

869525000

2. Enable Milesight D2D feature and define a unique D2D key that is the same as Milesight D2D agent devices. (Default D2D key: 5572404C696E6B4C6F52613230313823)

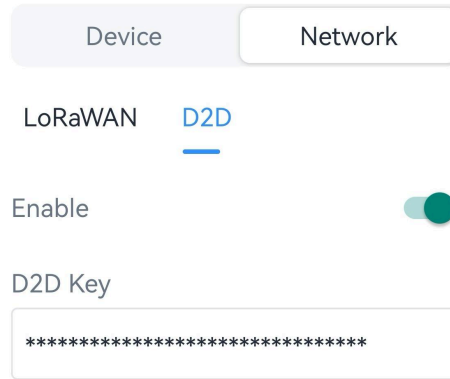

3. Enable **D2D Data Transmission Settings** and configure the settings.

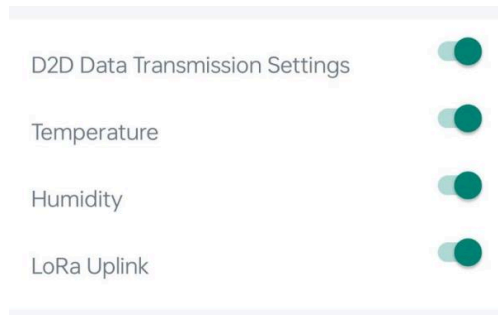

Parameters	Description
Temperature/Humidity	Enable to send temperature or humidity data periodically to Milesight devices that support Milesight D2D Receiving Settings.
LoRa Uplink	If disabled, the device will not send the temperature and humidity periodic packets to gateway.

### Milesight D2D Controller

TS201 supports working as a Milesight D2D controller device to send commands to trigger Milesight D2D agent devices.

1. Configure the RX2 datarate and RX2 frequency.



**Note:**

It is suggested to change the default values if there are many LoRaWAN<sup>®</sup> devices around.

Device
Network

LoRaWAN
D2D

---

Spreading Factor ⓘ

SF12-DR0
▼

TXPower

TXPower0-16 dBm
▼

---

RX2 Data Rate ⓘ

DR0 (SF12, 125 kHz)
▼

RX2 Frequency ⓘ

869525000

2. Enable and configure the threshold alarm settings.
3. Enable **D2D Controller Settings**, and define a unique D2D key that is the same as that of the D2D agent devices. (Default D2D Key: 5572404C696E6B4C6F52613230313823)
4. Enable one of statuses and configure 2-byte hexadecimal Milesight D2D command.

**Note:**

If you enable **LoRa Uplink**, a LoRaWAN<sup>®</sup> uplink packet that contains corresponding alarm status will be sent to gateway after the Milesight D2D command packet. Otherwise, the alarm packet will not send to LoRaWAN<sup>®</sup> gateway.

**Example:** When humidity threshold alarm is dismissed, the device will send a D2D command 0004 to Milesight D2D agent devices.

---

D2D Controller Settings	<input checked="" type="checkbox"/>
Temperature Threshold Triggered	<input type="checkbox"/>
Temperature Alarm Dismiss	<input type="checkbox"/>
Temperature Shift Threshold Triggered	<input type="checkbox"/>
Humidity Threshold Triggered	<input type="checkbox"/>
Humidity Alarm Dismiss	<input checked="" type="checkbox"/>
Control command	<input type="text" value="4"/>
LoRa Uplink ⓘ	<input type="checkbox"/>

---

Humidity Shift Threshold Triggered	<input type="checkbox"/>
------------------------------------	--------------------------

---

## Maintenance

### Upgrade

This chapter describes the steps to upgrade the device via ToolBox App.

1. Download firmware from Milesight official website to your smartphone.
2. Read the target device via ToolBox App, click **Upgrade** to upload the firmware file.
3. Click **Upgrade** to upgrade the device.



**Note:**

Operation on ToolBox is not supported during an upgrade.

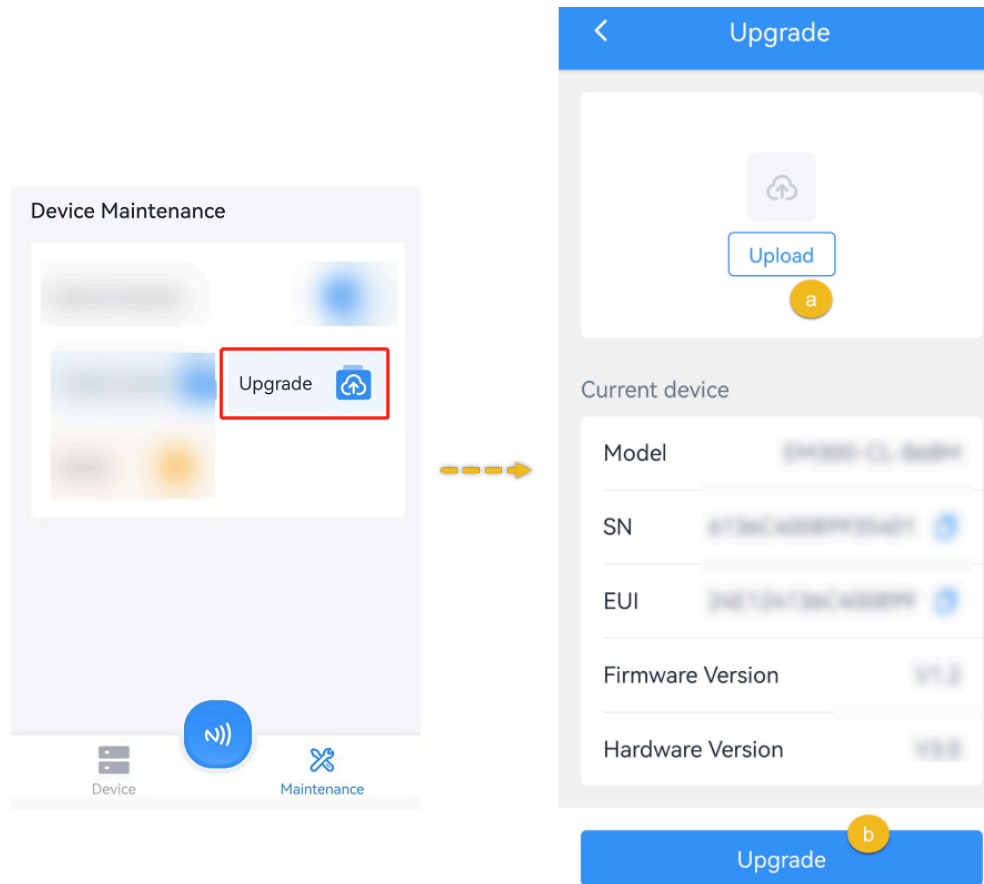

## Backup and Restore

This device supports configuration backup for easy and quick device configuration in bulks. Backup and restore is allowed only for devices with the same model and frequency band.

### Backup and Restore

1. Launch ToolBox App, attach the NFC area of smartphone to the device to read the configuration.
2. Edit the configuration as required, click **Set Template** to save current configuration as a template to the ToolBox App.

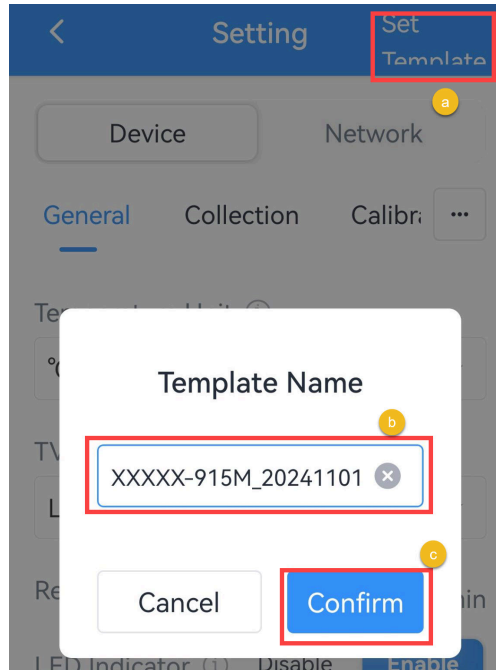

3. Go to **Device >Template** page.



4. Select and click the target template, click **Write** to import the configuration to target devices.

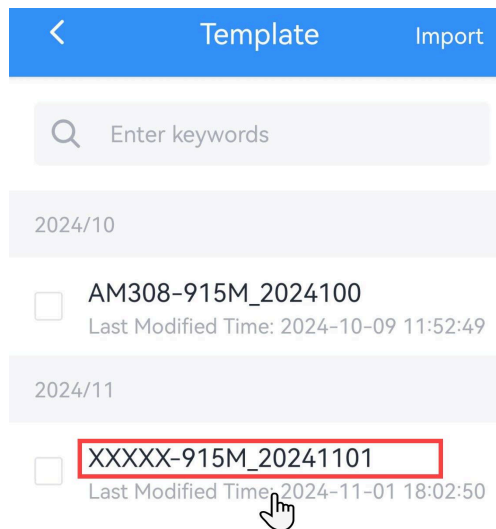

### Export and Delete Template

1. Check the box of the target template.
2. Click **Export** to export this template as JSON format file and save it to the smartphone, click **Delete** to delete this template from your Toolbox App.

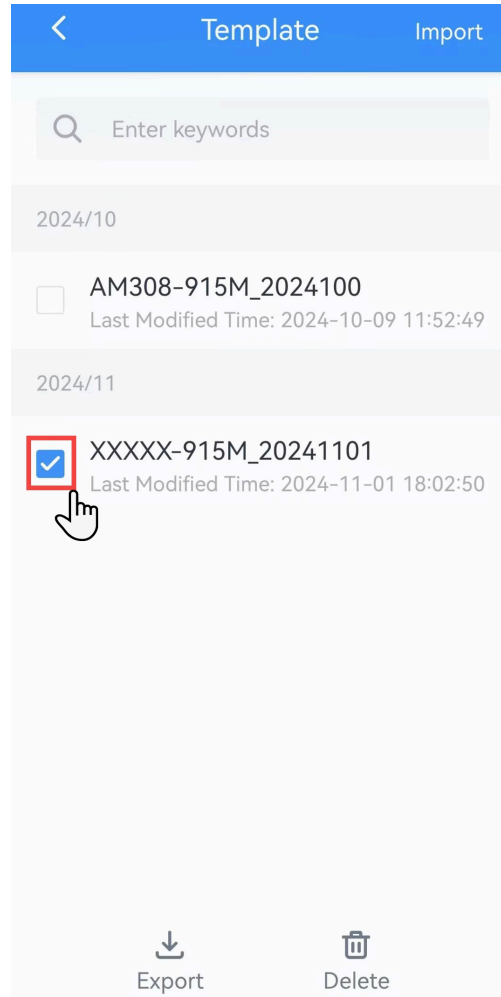

## Reset to Factory Default

**Via Hardware:** Hold on the reset button for more than 10s until the LED indicator quickly blinks.

**Via Toolbox App:** Click **Reset** and attach the smartphone to device to reset the device.

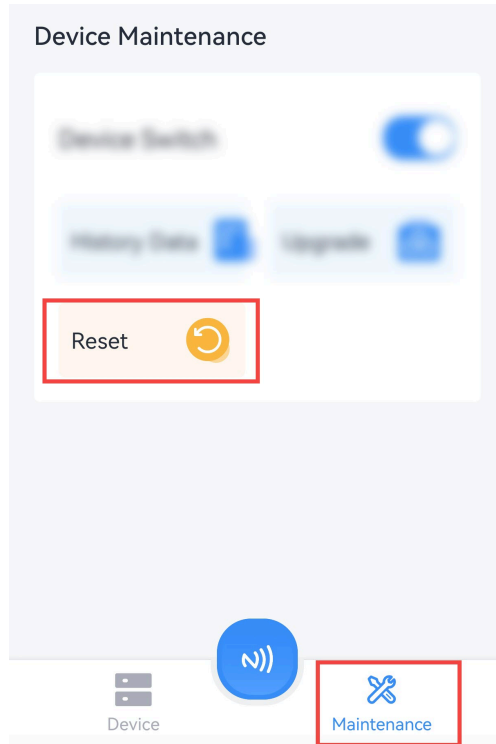

# Chapter 6. Installation

## Device Installation

### Wall Screw Mounting

1. Fix the wall plugs to a flat surface according to the device mounting holes, then secure the device to the wall plugs using screws.
2. Cover the screws with cover caps.

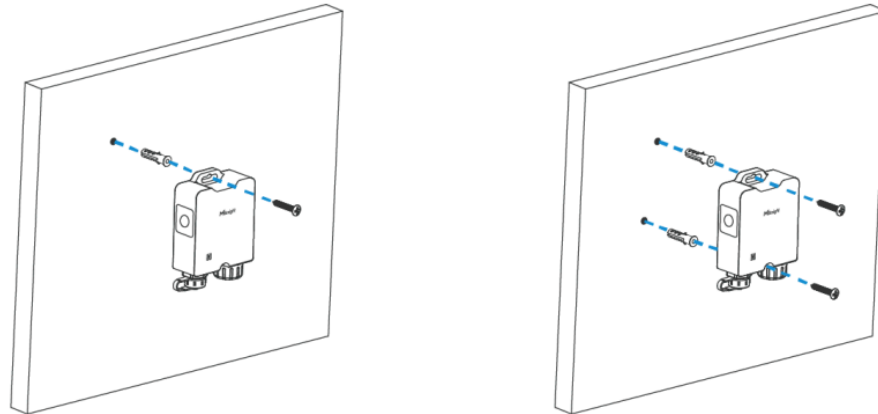

### Cable-tie Mounting

1. Pass a cable tie through the gap behind the device and wrap it to the pole.

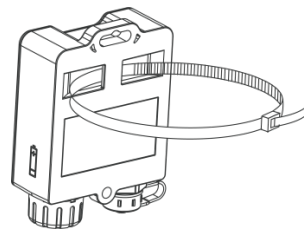

### Thermal Buffer Bottle (Alternative)

It is necessary to unplug the stopper inside the bottle cap, then restore the cap and insert the temperature probe into the bottle. When using, it can be placed to places like freezers and refrigerators to ensure more accurate temperature measurement.

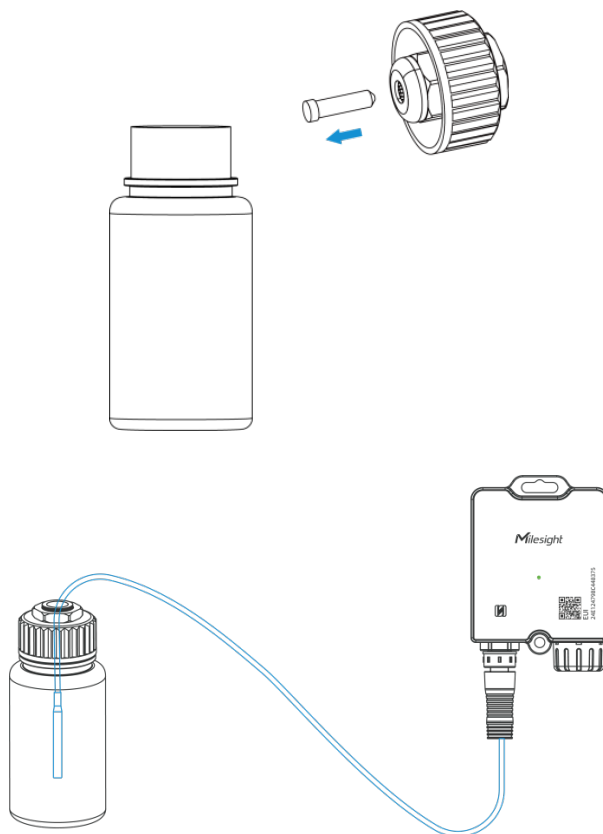

# Chapter 7. Battery Replacing

## Steps:

1. Insert the battery and tighten the battery compartment cover.

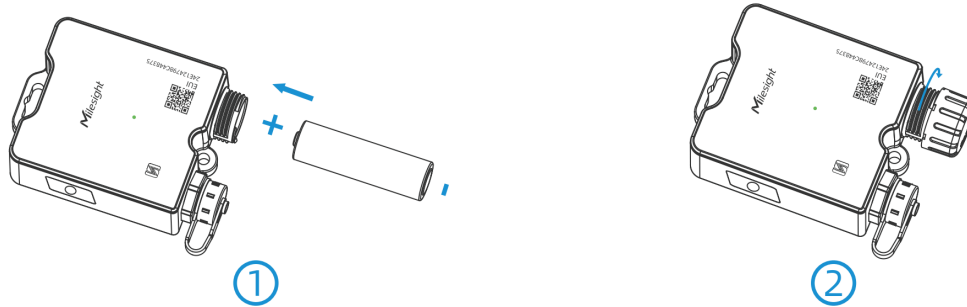

2. Connect the temperature (or humidity) probe.
3. Press and hold the power button for 3s until the indicator light turns on.

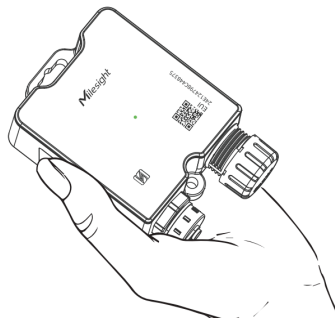

### Note:

- The device can only be powered by Li-SoCl<sub>2</sub> battery. The alkaline battery is not supported.
- Ensure the replacing battery is newest; otherwise it may shorten the battery life or cause inaccurate power calculation.
- The battery should be removed from the device if it is not used for an extended period.

# Chapter 8. Uplink and Downlink

## Overview

All messages are based on following format (HEX), the Data field should follow little-endian:

Channel1	Type1	Data1	Channel2	Type2	Data2	Channel3	...
1 Byte	1 Byte	N Bytes	1 Byte	1 Byte	N Bytes	1 Byte	...

For decoder examples please find files on <https://github.com/Milesight-IoT/SensorDecoders>.

## Uplink Data

### Basic Information

Item	Channel	Type	Byte	Description
Power On	ff	0b	1	Device is on
Protocol Version	ff	01	1	Example: 01=V1
Hardware Version	ff	09	2	Example: 03 10 = V3.1
Software Version	ff	0a	2	Example: 03 01 = V3.1
Device Type	ff	0f	1	00: Class A, 01: Class B, 02: Class C, 03: Class C to B
Serial Number	ff	16	8	16 digits
TSL Version	ff	ff	2	Example: 01 00=>V1.0
Reset Report	ff	fe	1	ff, report after reset to factory default
Probe ID	ff	a0	9	Temperature Version: 11+DS18B20 Probe ID TH Version: 1200000000+Probe ID  <b>Note:</b> When probe ID is reported as all "F", it means acquisition failure.

**Example:**

1. The device will report a basic information packet whenever joining the network.

f0bff ff0101 ffff0101 fffeff ff166809e08056200001 ff090100 ff0a0102 ff0f00 ffa0112883c2b50f0000043		
Channel	Type	Value
ff	0b	ff
ff	01	01=V1
ff	ff	TSL Version: 0101=V1.1
ff	fe	ff
ff	16	Serial Number: 6809e08056200001
ff	09	Hardware version: 0100=V1.0
ff	0a	Software version: 0102=V1.2
ff	0f	00 = Class A
ff	a0	DS18B20 Probe ID: 284fa8b50f00000d

2. The device will report a probe ID packet when the probe is removed or changed.

ffa011284fa8b50f00000d		
Channel	Type	Value
ff	a0	DS18B20 Probe ID: 284fa8b50f00000d

**Periodic Report**

The device supports the sensor data according to reporting interval.

Item	Channel	Type	Byte	Description
Battery Level	01	75	1	UINT8, Unit: %
Temperature	03	67	2	INT16*0.1, Unit: °C, Resolution: 0.1°C
Relative Humidity	04	68	1	UINT8*0.5, Unit: %RH

**Example:**

## 1. Temperature version.

017564 03671101		
Channel	Type	Value
01	75	Battery Level: 64 => 100%
03	67	Temperature: 1101 => 0111 => $273 \times 0.1 = 27.3^{\circ}\text{C}$

## 2. TH version.

017564 03671101 046850		
Channel	Type	Value
01	75	Battery Level: 64 => 100%
03	67	Temperature: 1101 => 0111 => $273 \times 0.1 = 27.3^{\circ}\text{C}$
04	68	Relative Humidity: $50 = 80 \times 0.5 = 40\% \text{RH}$

## Alarm Report

The device supports to report below types of alarm report packets.

Item	Channel	Type	Byte	Description
Temperature Ab-normal Report	b3	67	1	00 - Abnormal collection report 01 - Temperature overrange report
Humidity Ab-normal Report	b4	68	1	00 - Abnormal collection report 01 - Humidity overrange report
Temperature Threshold Alarm	83	67	3	<b>Byte 1-2:</b> Temperature, $\text{INT}16 \times 0.1$ , Unit: $^{\circ}\text{C}$ <b>Byte 3:</b> 00 -Alarm dismiss, 01 -Alarm
Temperature Shift Threshold (Change) Alarm	93	67	5	<b>Byte 1-2:</b> Temperature, $\text{INT}16 \times 0.1$ , Unit: $^{\circ}\text{C}$ <b>Byte 3-4:</b> Temperature_change, $\text{INT}16 \times 0.1$ , Unit: $^{\circ}\text{C}$ <b>Byte 5:</b> 02

Item	Channel	Type	Byte	Description
Humidity Threshold Alarm	84	68	2	<b>Byte 1:</b> Relative Humidity, $UINT8*0.5$ , Unit: %RH <b>Byte 2:</b> 00 -Alarm dismiss, 01 -Alarm
Humidity Shift Threshold(Change) Alarm	94	68	3	<b>Byte 1:</b> Relative Humidity, $UINT8*0.5$ , Unit: %RH <b>Byte 2:</b> Relative Humidity_change, $UINT8*0.5$ , Unit: %RH <b>Byte 3:</b> 02

**Example:**

1. Temperature abnormal alarm: report when the temperature is overrange.

b367 01		
Channel	Type	Value
b3	67	01 => Temperature overrange

2. Temperature and humidity threshold alarm: report when threshold alarm is enabled.

8367 340101 8468 4e01		
Channel	Type	Value
83	67	34 01 => 01 34 => $308*0.1 = 30.8^{\circ}C$ 01 => Temperature threshold alarm
84	68	4e=> $78*0.5=39\%RH$ 01 => Relative humidity threshold alarm

3. Temperature shift threshold (change) alarm: report when shift threshold (change) alarm is enabled.

93d7 fa00 0700 02		
Channel	Type	Value
93	67	Temperature: fa 00 => 00 fa => 250*0.1= 25°C  Temperature change: 07 00 => 00 07 => 7*0.1=0.7°C  02 => Temperature change alarm

### Historical Data

The device will report retransmission data or stored data as below format.

Item	Channel	Type	Byte	Description
Historical Data	20	ce	9	<p><b>Byte 1-4:</b> Data time stamp, UINT32, Unit: s</p> <p><b>Byte 5:</b></p> <p>01: Temperature sensor</p> <p>02: TH sensor</p> <p><b>Byte 6-7:</b> Temperature, INT16*0.1, Unit: °C</p> <p><b>Byte 8:</b> Relative Humidity, UINT8*0.5, Unit: %RH</p> <p><b>Byte 9:</b></p> <p>Bit3~Bit0: Abnormal Type</p> <ul style="list-style-type: none"> <li>• 0001: Periodic report</li> <li>• 0010: Temperature Alarm report</li> <li>• 0011: Temperature Alarm dismiss report</li> <li>• 0100: Humidity Alarm report</li> <li>• 0101: Humidity Alarm dismiss report</li> <li>• 0110: Collect and report immediately</li> </ul> <p>Bit5~Bit4:</p>

Item	Channel	Type	Byte	Description
				<ul style="list-style-type: none"> <li>• 00: Normal</li> <li>• 01: Humidity Collection abnormal</li> <li>• 10: Humidity Overrange report</li> </ul> Bit7~Bit6: <ul style="list-style-type: none"> <li>• 00:Normal</li> <li>• 01: Temperature Collection abnormal</li> <li>• 10: Temperature Overrange report</li> </ul>

**Example:**

20ce 0d 75 5b 63 02 bdff 2e 01			
Channel	Type	Time Stamp	Value
20	ce	0d 75 5b 63 => 63 5b 75 0d=1666938125s	02: TH sensor  Temperature: bdff = ff bd => -67*0.1=-6.7°C  Humidity: 2e => 46*0.5=23%RH  01 => Normal +Periodic Report

## Downlink Command

### Device Configuration Command

This device supports downlink commands for configuration and control. The downlink application port is 85 by default.

#### General Settings

Item	Channel	Type	Byte	Description
Reboot	ff	10	1	ff
Collect Interval	ff	02	2	UINT16, Unit: s

Item	Channel	Type	Byte	Description
Report Interval	ff	8e	3	<b>Byte 1:</b> 00 <b>Byte 2-3:</b> UINT16, Unit: minute
Data Storage	ff	68	1	00: Disable, 01: Enable
Data Retransmission	f9	0d	3	<b>Byte 1:</b> 01-enable; 00-disable <b>Byte 2-3:</b> interval time, Unit:s,Range: 30~1200s, default: 600s
UTC Time Zone	ff	bd	2	INT16/60
Temperature Unit	ff	eb	1	00-°C, 01-°F  <b>Note:</b> the reported unit is fixed as °C.
Button Lock	f9	69	1	00-Disable button lock 01-Enable Turn Off lock 02-Enable Collect and Report lock 03-Enable both lock

**Example:**

1. Set report interval as 20 minutes.

ff8e001400		
Channel	Type	Value
ff	8e	1400=>0014=20minutes

2. Set time zone as UTC-4.

ffbd10ff		
Channel	Type	Value
ff	bd	10 ff => ff 10 = -240/60=-4

3. Set data retransmission interval as 100s.

f90d 01 6400		
Channel	Type	Value
f9	0d	01 => enable Data Retransmission 6400 => 00 64 => 100s

### Enquiry Probe ID

Item	Channel	Type	Byte	Description
Enquiry Probe ID	f9	31	1	00
ACK Packet Resend Times	f9	32	3	<p><b>Byte 1-2:</b> 0000</p> <p><b>Byte 3:</b> Resend Times, Range:0 ~ 10, Default: 1</p> <p> <b>Note:</b> If a periodic packet is combined with a probe ID packet, the ACK packet resend times will be determined according to this downlink command; however, if a periodic packet is not combined with a probe ID packet, the ACK packet will be resent only once.</p>

#### Example:

Get Probe ID.

f931 00		
Channel	Type	Value
f9	31	00 => Get Probe ID

### Calibration Settings

Channel	Type	Byte	Description
ff	ea	3	<p><b>Byte 1:</b></p> <p>80-Temperature enable 00-Temperature disable</p> <p>81-Humudity enable 01-Humudity disable</p> <p><b>Byte 2-3:</b></p> <p>Temperature calibration value, INT16*0.1, Unit: °C, Range: -200~1000 (or Humidity calibration value, INT16*0.5, Unit: %RH, Range: -100~100)</p>

#### Example:

Enable temperature calibration and set the calibration value.

ffea 80 6400		
Channel	Type	Value
ff	ea	<p>80 =&gt; enable temperature calibration</p> <p>6400 =&gt; 00 64 =&gt; 100*0.1 = 10°C</p>

### Alarm Settings

Item	Channel	Type	Byte	Description
Alarm Reporting Times	ff	f2	2	Range: 1~1000

Item	Channel	Type	Byte	Description
Alarm Dismiss Report	ff	f5	1	01-enable; 00-disable
Threshold Alarm	f9	0b	7	<p><b>Byte 1:</b> 01-Temperature, 03-Humidity</p> <p><b>Byte 2:</b> 01 - below; 02 - over; 03 - within; 04 - below or over</p> <p><b>Byte 3-4:</b> Max. Temperature, INT16*0.1, Unit: °C (or Max. Humidity, UINT16*0.5, Unit: %RH)</p> <p><b>Byte 5-6:</b> Min. Temperature, INT16*0.1, Unit: °C (or Min. Humidity, UINT16*0.5, Unit: %RH)</p> <p><b>Byte 7:</b> 01-enable; 00-disable</p>
Shift Threshold(Change) Alarm	f9	0c	4	<p><b>Byte 1:</b> 02-Temperature, 04-Humidity</p> <p><b>Byte 2-3:</b> Max. Temperature, INT16*0.1, Unit: °C, range: 0.1 ~ 100 (or Max. Humidity, UINT8*0.5, Unit: %RH)</p> <p><b>Byte 4:</b> 01-enable; 00-disable</p>
LED Threshold Alarm Indicator	f9	6a	1	01-enable; 00-disable

**Example:**

Set a temperature threshold alarm as above 37°C.

f90b 01 02 7201 0000 01		
Channel	Type	Value
f9	0b	01 => set threshold alarm

f90b 01 02 7201 0000 01		
Channel	Type	Value
		02 => above 72 01=> 01 72 => 370*0.1=37°C 01 => enable threshold alarm

## D2D Settings

Item	Channel	Type	Byte	Description
D2D Sensor Data Transmission Setting	f9	63	4	<p><b>Byte 1:</b> 01-enable, 00-disable</p> <p><b>Byte 2:</b> 01-enable LoRa Uplink, 00-disable LoRa Uplink</p> <p><b>Byte 3:</b></p> <p>00-Temperature and humidity disable</p> <p>01-Temperature enable</p> <p>02-Humidity enable</p> <p>03-Temperature and humidity disable</p> <p><b>Byte 4:</b> 00</p>
Milesight D2D Controller	f9	66	1	01-enable; 00-disable
D2D Key	ff	35	8	The first 16 digits of D2D key, and the last 16 digits are fixed as 0.
D2D Controller Settings	ff	96	8	<p>First 16 digits, last 16 digits are fixed as 0</p> <p><b>Byte 1:</b></p> <p>01-Temperature Threshold Triggered</p> <p>02-Temperature Alarm Dismiss</p> <p>03-Temperature Shift Threshold Triggered</p>

Item	Channel	Type	Byte	Description
				04-Humidity Threshold Triggered 05-Humidity Alarm Dismiss 06-Humidity Shift Threshold Triggered <b>Byte 2:</b> 01-enable, 00-disable <b>Byte 3:</b> 01-enable LoRa Uplink, 00-disable LoRa Uplink <b>Byte 4-5:</b> D2D control command <b>Byte 6-8:</b> 000000

**Example:**

1. Set D2D Key as 12345678123456780000000000000000.

ff35 1234567812345678		
Channel	Type	Value
ff	35	1234567812345678

2. When temperature reaches the threshold, send D2D command 0001.

ff96 010101 0100 000000		
Channel	Type	Value
ff	96	01=Temperature Threshold Triggered. 01=enable, 01=enable LoRa Uplink, D2D Command: 0100=>0001

### Device Configuration Enquiry

The device supports enquiring the device configuration via f96f command. The device will send the replies with the same format as downlink commands.

Item	Channel	Type	Byte	Command
Temperature Unit	f9	6f	1	01
Button Lock	f9	6f	1	02
Milesight D2D Data Transmission	f9	6f	1	03
Milesight D2D Controller	f9	6f	1	04
D2D Controller: Temperature Alarm	f9	6f	1	05
D2D Controller: Temperature Alarm Dismiss	f9	6f	1	06
D2D Controller: Temperature Shift Alarm Dismiss	f9	6f	1	07
D2D Controller: Humidity Threshold Triggered	f9	6f	1	08
D2D Controller: Humidity Alarm Dismiss	f9	6f	1	09
D2D Controller: Humidity Shift Threshold Triggered	f9	6f	1	0a
Temperature Calibration	f9	6f	1	0b
Humidity Calibration	f9	6f	1	0c
Temperature Threshold	f9	6f	1	0d
Temperature Shift Threshold	f9	6f	1	0e
Humidity Threshold	f9	6f	1	0f
Humidity Shift Threshold	f9	6f	1	10
LED Threshold Alarm Indicator	f9	6f	1	11
Collecting Interval	f9	6f	1	12
Reporting Interval	f9	6f	1	13
Alarm Dismiss Report	f9	6f	1	14

Item	Channel	Type	Byte	Command
Alarm Reporting Times	f9	6f	1	15
Data Retransmission	f9	6f	1	16
Data Storage	f9	6f	1	17
Data Retrievalability	f9	6f	1	18
ACK Packet Resend Times	f9	6f	1	19

**Example:**

1. Query the current humidity threshold setting.

f9 6f 0f		
Channel	Type	Description
f9	6f	0f => Humidity threshold

Reply:

f9 0b 03 02 1e00 0000 01		
Channel	Type	Value
f9	0b	03=>Humidity 02=>over 1e00=> 001e=>30*0.5=15% 01=>enable Threshold Alarm

2. Query the current report interval.

f9 6f 13		
Channel	Type	Description
f9	6f	0f => Humidity threshold

Reply:

ff 8e 00 0100		
Channel	Type	Value
f9	8e	0100=>0001=1 min

## Historical Data Enquiry

The device supports data retrievability feature to send downlink command to enquire the historical data stored in the device. Before that, ensure the device time is correct and data storage feature was enabled to store data.

### Command Format:

Item	Channel	Type	Byte	Description
Enquire Data in Time Point	fd	6b	4	Unix timestamp, Unit: s
Enquire Data in Time Range	fd	6c	8	Byte 1-4: Start timestamp, Unit: s Byte 5-8: End timestamp, Unit: s
Stop Query Data Report	fd	6d	1	ff
Data Retrieval Interval	ff	6a	3	Byte 1: 01 Byte 2-3: UINT16, Unit: s, Range: 30~1200, Default: 60

### Reply Format:

Item	Channel	Type	Byte	Description
Enquiry Result	fc	6b/6c	1	00: Enquiry success. The device will report the historical data according to data retrievability interval. 01: Time point or time range invalid

Item	Channel	Type	Byte	Description
				02: No data in this time or time range

**Note:**

1. Use [Unix Timestamp Converter](#) to calculate the time.
2. The device only uploads no more than 300 data records per range enquiry.
3. When enquiring the data in time point, it will upload the data which is closest to the search point within the reporting interval range. For example, if the device's reporting interval is 10 minutes and users send command to search for 17:00's data, if the device find there is data stored in 17:00, it will upload this data; if not, it will search for data between 16:50 to 17:10 and upload the data which is closest to 17:00.

**Example:**

Enquire the historical data in a time range.

fd6c 64735b63 7c885b63		
Channel	Type	Value
fd	6c	Start time: 64 73 5b 63 => 63 5b 73 64 = 1666937700s End time: 7c 88 5b 63 => 63 5b 88 7c = 1666943100s

Reply:

fc6c00		
Channel	Type	Value
fc	6c	00: Enquiry success

20ce 0d 75 5b 63 02 bfff 2e 01			
Channel	Type	Time Stamp	Value
20	ce	0d 75 5b 63 => 63 5b 75 0d=1666938125s	02: TH sensor Temperature: bfff = ff bd => -67*0.1=-6.7°C

20ce 0d 75 5b 63 02 bfff 2e 01			
Channel	Type	Time Stamp	Value
			Humidity: 2e => $46 \times 0.5 = 23\%RH$ 01 => Normal +Periodic Report

## Chapter 9. Services

Milesight provides customers with timely and comprehensive technical support services. End-users can contact your local dealer to obtain technical support. Distributors and resellers can contact directly with Milesight for technical support.

Technical Support Mailbox: [iot.support@milesight.com](mailto:iot.support@milesight.com)

Online Support Portal: <https://support.milesight-iot.com>

Resource Download Center: <https://www.milesight.com/iot/resources/download-center/>

### **MILESIGHT CHINA**

TEL: +86-592-5085280

FAX: +86-592-5023065

Add: Building C09, Software Park Phase III, Xiamen 361024, Fujian, China