

# IoT Controller

Featuring LoRaWAN®

**UC300**

User Guide



## Safety Precautions

Milesight will not shoulder responsibility for any loss or damage resulting from not following the instructions of this operating guide.

- ❖ The device must not be remodeled in any way.
- ❖ Do not place the device close to objects with naked flames.
- ❖ Do not place the device where the temperature is below/above the operating range.
- ❖ Power off the device when installing or wirings.
- ❖ Make sure electronic components do not drop out of the enclosure while opening.
- ❖ The device must never be subjected to shocks or impacts.

## Declaration of Conformity

UC300 is in conformity with the essential requirements and other relevant provisions of the CE, FCC, and RoHS.



Copyright © 2011-2025 Milesight. All rights reserved.

All information in this guide is protected by copyright law. Whereby, no organization or individual shall copy or reproduce the whole or part of this user guide by any means without written authorization from Xiamen Milesight IoT Co., Ltd.

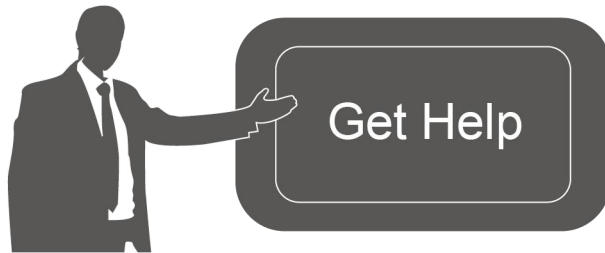

For assistance, please contact

Milesight technical support:

Email: [iot.support@milesight.com](mailto:iot.support@milesight.com)

Tel: 86-592-5085280

Fax: 86-592-5023065

Address: Building C09, Software Park III,  
Xiamen 361024, China

## Revision History

Date	Doc Version	Description
Mar. 17, 2022	V 1.0	Initial version
June 30, 2023	V 2.0	Update based on hardware V2.x

# Contents

1. Product Introduction .....	4
1.1 Overview .....	4
1.2 Features .....	4
2. Hardware Introduction .....	4
2.1 Packing List .....	4
2.2 Hardware Overview .....	5
2.3 Wiring Examples .....	5
2.4 LED Indicators .....	7
2.5 Reset Button .....	7
2.6 Dimensions (mm) .....	8
3. Hardware Installation .....	8
3.1 Antenna Installation .....	8
3.2 Device Installation .....	8
3.3.1 Wall Mounting .....	8
3.3.2 DIN Rail Mounting .....	9
4. Operation Guide .....	10
4.1 Log in the ToolBox .....	10
4.2 LoRaWAN Settings .....	11
4.3 Data Interface Settings .....	15
4.3.1 Basic Settings .....	15
4.3.2 Digital Input/Pulse Counter .....	15
4.3.3 Digital Output .....	17
4.3.4 RS485 .....	17
4.3.5 RS232 .....	20
4.3.6 Analog Input/PT100 .....	21
4.4 IF-THEN Command .....	22
4.5 Milesight D2D Settings .....	24
4.6 Data Storage .....	27
4.7 Data Retransmission .....	29
4.8 Maintenance .....	30
4.8.1 Upgrade .....	30
4.8.2 Backup .....	31
4.8.3 Reset to Factory Default .....	31
5. Device Payload .....	32

## 1. Product Introduction

### 1.1 Overview





UC300 is an IoT controller used for remote control and data acquisition from multiple sensors. It contains different I/O interfaces such as analog inputs, digital inputs, relay outputs, serial ports and so on, which support remote device data transmission and control via LoRaWAN<sup>®</sup>. Besides, UC300 supports multiple trigger conditions and actions which works autonomously even when the network drops.

### 1.2 Features

- Easy to connect with diverse wired sensors through DI/DO/AI/PT100/RS232/RS485 interfaces
- Multiple triggering conditions and actions
- Embedded watchdog for work stability
- Industrial metal case design with wide operating temperature range
- Compliant with standard LoRaWAN<sup>®</sup> gateways and network servers
- Quick and easy management with Milesight IoT Cloud solution

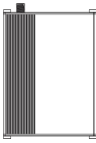
## 2. Hardware Introduction

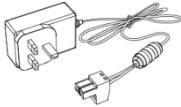
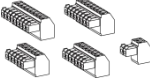
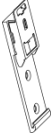
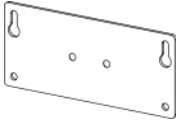
### 2.1 Packing List

			
1 x	1 x	1 x	5 x
UC300 Device	LoRaWAN <sup>®</sup> Antenna	Power Adapter	Terminal Blocks
			
1 x DIN Rail Mounting Clip	1 x Wall Mounting Bracket	4 x Wall Mounting Kits	4 x Fixing Screws



1 ×  
Quick Start Guide

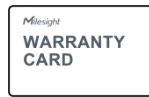

1 × Warranty  
Card



If any of the above items is missing or damaged, please contact your sales representative.

## 2.2 Hardware Overview

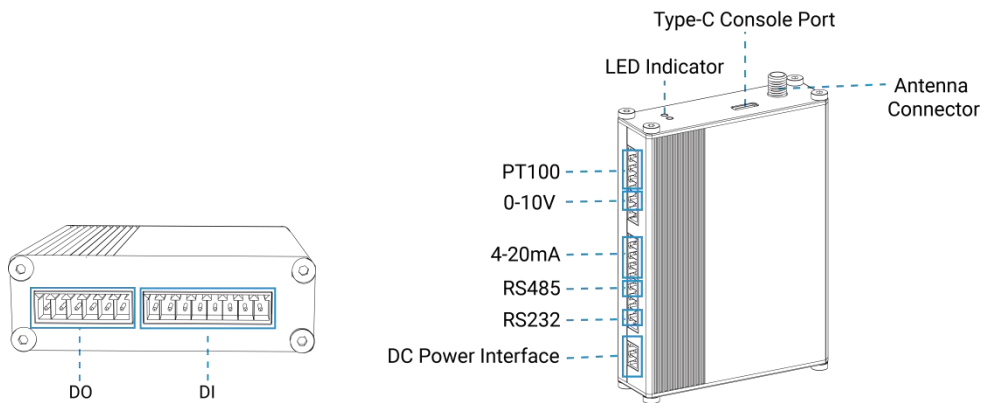

## 2.3 Wiring Examples

### (1) Digital input wiring:

Dry Contact:

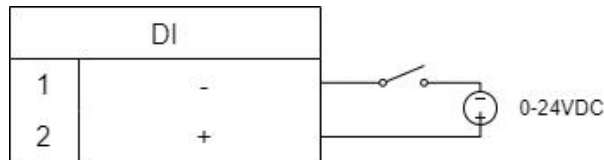

Wet Contact:

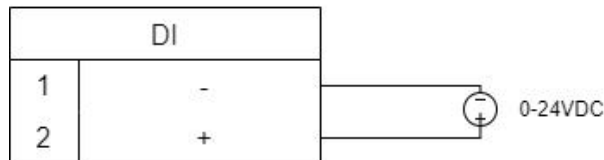

### (2) Relay output wiring:

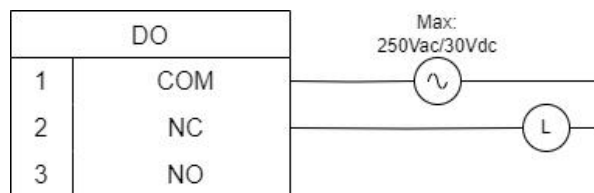

### (3) 4-20mA wiring:

3-Wire:

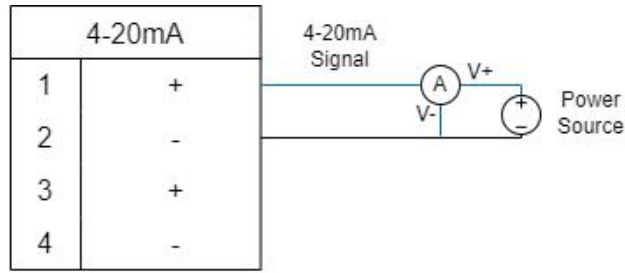

2-Wire:

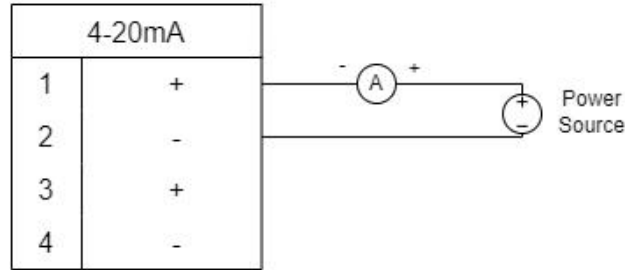

(4) 0-10V wiring:

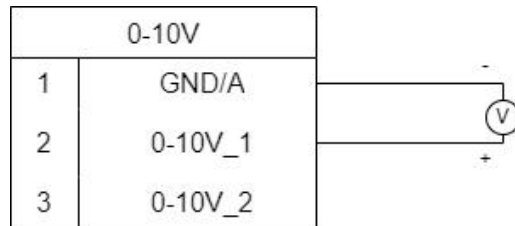

(5) PT100 wiring:

3-Wire:

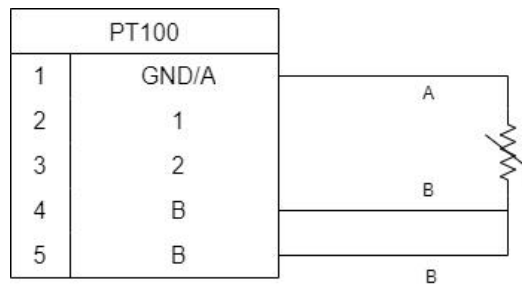

2-Wire:

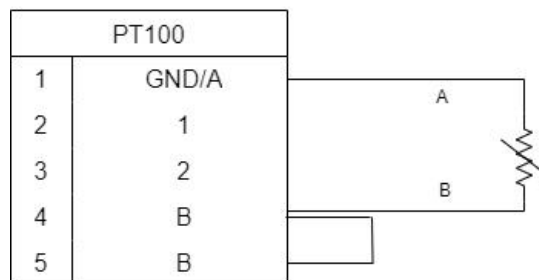

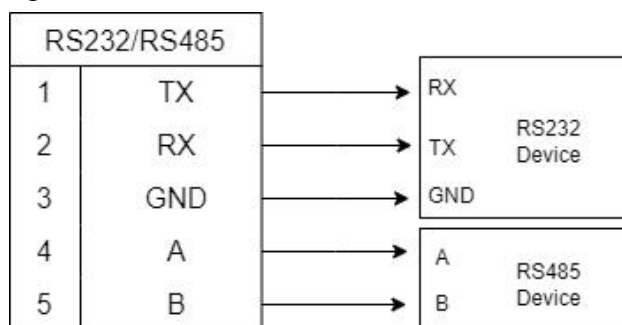
**(6) RS232/RS485 wiring:****RS485 Terminal Resistor<sup>1</sup>:**

DIP Switch	Description
1 on 2 off 3 off	Add 120 $\Omega$ resistor between A and B
1 off 2 on 3 off	Add pull-down resistor on B
1 off 2 off 3 on	Add pull-up resistor on A

**2.4 LED Indicators**

LED	Indication	Status	Description
SYS	System Status	Static On	System works
		Slowly Blinks	Fail to acquire data from data interfaces
		Static On	System error
ACT	Network Status	Off	Not join to network
		Blinks as Requests	Send join network requests
		Blinks Twice $\rightarrow$ Static On	Succeed to join to network
		Blinks Once	Succeed to send uplinks
		Blinks Twice	Fail to send uplinks
		Blinks Twice	Receive downlinks

**2.5 Reset Button**

There is a reset button inside the device.

Function	Description	
	SYS LED	Action
Reset	Static Green	Press and hold the reset button for more than 10 seconds.
	Static Green $\rightarrow$ Rapidly Blinking	Release the button and wait.
	Off $\rightarrow$ Static Green	The device resets to factory default.

<sup>1</sup> Add resistors to avoid data-corrupting reflections if RS485 data rate is high or cable length is long.

## 2.6 Dimensions (mm)

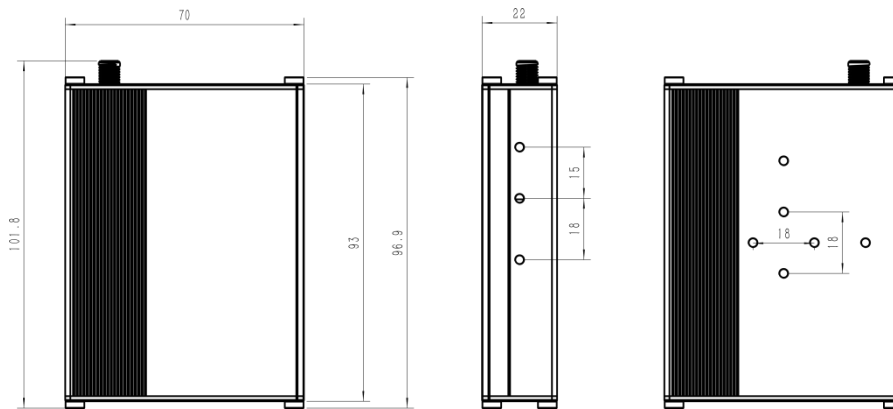

## 3. Hardware Installation

### 3.1 Antenna Installation

Rotate the antenna into the antenna connector accordingly.

The external antenna should be installed vertically always on a site with a good signal.

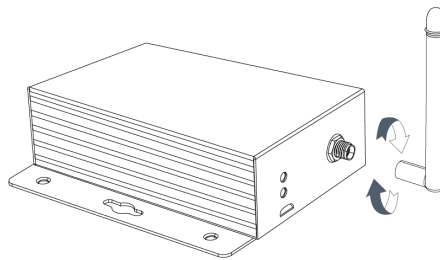

### 3.2 Device Installation

UC300 device can be placed on a desktop or mounted to a wall or a DIN rail.

#### 3.3.1 Wall Mounting

1. Fix the wall mounting bracket to the device with 2 screws.

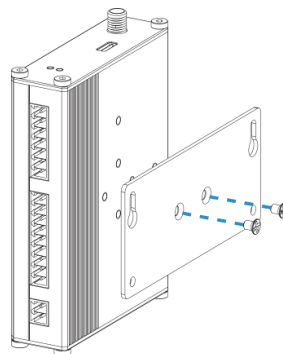

2. Drill 4 holes on the wall according to the bracket, then fix the wall plugs into the wall.
3. Fix the device to the wall plugs with screws. When installation, it's suggested to fix the two

screws on the top at first.

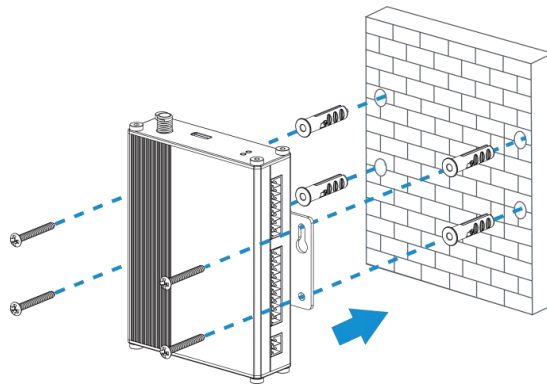

### 3.3.2 DIN Rail Mounting

1. Fix the mounting clip to the device with 3 screws.

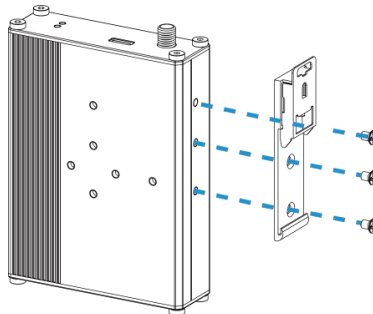

You can also try below installation methods:

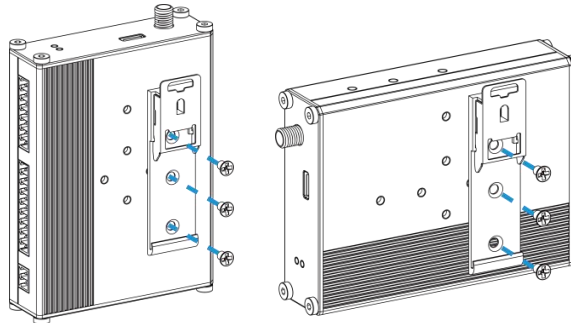

2. Hang the device to the DIN rail. The width of DIN rail is 3.5cm.

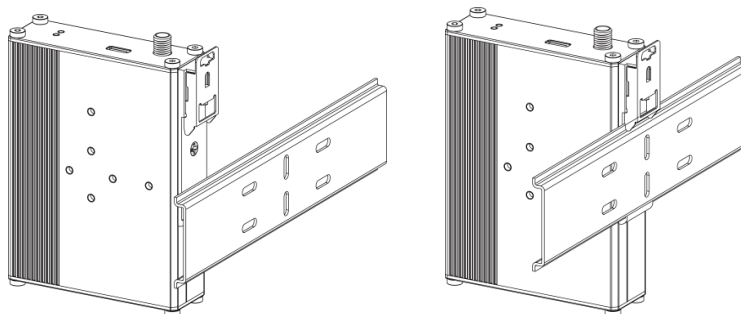

## 4. Operation Guide

### 4.1 Log in the ToolBox

1. Download ToolBox software from Milesight IoT website.
2. Power on the UC300 device, then connect it to computer via type-C port.

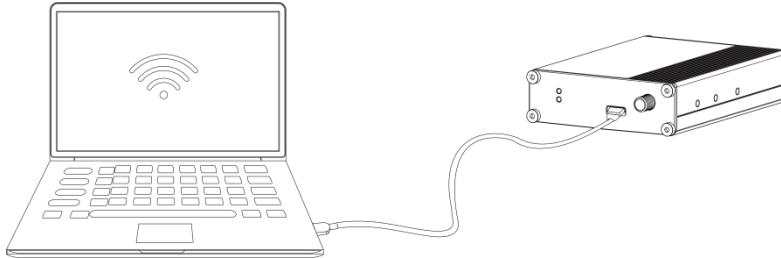

3. Open the ToolBox and select type as **General**, then click password to log in ToolBox. (Default password: **123456**)

A screenshot of a software dialog box titled "ToolBox Settings". The dialog has a blue header bar with a close button (X) on the right. The main area contains several configuration options, each with a label and a control element:

- Type: A dropdown menu showing "General".
- Serial port: A dropdown menu showing "COM4".
- Login password: A text input field.
- Baud rate: A dropdown menu showing "115200".
- Data bits: A dropdown menu showing "8".
- Parity bits: A dropdown menu showing "None".
- Stop bits: A dropdown menu showing "1".

At the bottom of the dialog, there are two buttons: "Save" and "Cancel".

4. After logging in the ToolBox, you can change device settings.

**Status >**

Model:	UC300-470M
Serial Number:	6445B43411300001
Device EUI:	24e124445b434113
Firmware Version:	01.01-a8
Hardware Version:	1.0
Join Status:	Activate
RSSI/SNR:	-116/-22
Channel Mask:	000000000000000000ff00
Uplink Frame-counter:	7
Downlink Frame-counter:	0
Device Time:	2022-03-17 09:47:19 <a href="#">Sync</a>

## 4.2 LoRaWAN Settings

LoRaWAN settings is used for configuring the transmission parameters in LoRaWAN® network.

### Basic LoRaWAN Settings:

Go to **LoRaWAN Settings > Basic** to configure join type, App EUI, App Key and other information. You can also keep all settings by default.

Device EUI	<input type="text" value="24E124445D112669"/>
App EUI	<input type="text" value="24E124C0002A0001"/>
Application Port	<input type="text" value="85"/>
Join Type	<input type="text" value="OTAA"/>
LoRaWAN Version	<input type="text" value="V1.0.2"/>
Class Type	<input type="text" value="Class C"/>
Application Key	<input type="text" value="*****"/>
RX2 Data Rate	<input type="text" value="DR0 (SF12, 125 kHz)"/>
RX2 Frequency	<input type="text" value="505300000"/>
Spread Factor	<input type="text" value="SF12-DR0"/>
Confirmed Mode	<input type="checkbox"/>
Rejoin Mode	<input checked="" type="checkbox"/>
Set the number of packets sent	<input type="text" value="32"/> packets
TXPower	<input type="text" value="TXPower0-19.15 dBm"/>

Parameters	Description
Device EUI	Unique ID of the device on the label.
App EUI	Default App EUI is 24E124C0002A0001.
Application Port	The port used for sending and receiving data (RS232 data excluded), default port is 85.
Join Type	OTAA and ABP modes are available.
LoRaWAN Version	V1.0.2, V1.0.3 are available.
Class Type	It's fixed as Class C.
Application Key	Appkey for OTAA mode, default value: "Device EUI" + "Device EUI" (since Q4 of 2025). Example: 24e124123456789024e1241234567890 <b>Note:</b> The default value of earlier devices is 5572404C696E6B4C6F52613230313823.
Device Address	DevAddr for ABP mode, default is the 5 <sup>th</sup> to 12 <sup>th</sup> digits of SN.
Network Session Key	Nwkskey for ABP mode, default is 5572404C696E6B4C6F52613230313823.
Application Session Key	Appskey for ABP mode, default is 5572404C696E6B4C6F52613230313823.
RX2 Data Rate	RX2 data rate to receive downlinks.

RX2 Frequency	RX2 frequency to receive downlinks. Unit: Hz
Spread Factor	If ADR is disabled, the device will send data via this spread factor.
Confirmed Mode	If the device does not receive ACK packet from network server, it will resend data once.
Rejoin Mode	Reporting interval $\leq$ 30 mins: the device will send a specific number of LinkCheckReq MAC packets to the network server with periodic or threshold uplinks everytime more than 25~35 mins passes to validate connectivity; If there is no response, the device will re-join the network. Reporting interval $>$ 30 mins: the device will send a specific number of LinkCheckReq MAC packets to the network server every reporting interval to validate connectivity; If there is no response, the device will re-join the network.
Set the number of packets sent	When rejoin mode is enabled, set the number of LinkCheckReq packets sent. <b>Note:</b> the actual sending number is <b>Set the number of packet sent + 1</b> .
ADR Mode	Allow network server to adjust datarate of the device.
Tx Power	Transmit power of device.

**Note:**

- 1) Please contact sales for device EUI list if there are many units.
- 2) Please contact sales if you need random App keys before purchasing.
- 3) Select OTAA mode if you use Milesight IoT Cloud to manage devices.
- 4) Only OTAA mode supports rejoin mode.

**LoRaWAN Frequency Settings:**

Go to **LoRaWAN Settings > Channel** to select supported frequency and select channels to send uplinks. Make sure the channels match the LoRaWAN® gateway.

**Note:** When Single-Channel Mode is enabled, only one channel can be selected to send uplinks and the ADR will not work. Please enable Single-Channel Mode if you connect device to DS7610.

Basic
Channel

Supported Frequency : EU868    Single-Channel Mode:

<input type="checkbox"/>	Index	Frequency/MHz	Min Datarate	Max Datarate
<input checked="" type="checkbox"/>	0	<input style="width: 80%;" type="text" value="868.1"/>	<span style="border: 1px solid #ccc; padding: 2px;">5-SF7BW125</span>	<span style="border: 1px solid #ccc; padding: 2px;">0-SF12BW125</span>
<input checked="" type="checkbox"/>	1	<input style="width: 80%;" type="text" value="868.3"/>	<span style="border: 1px solid #ccc; padding: 2px;">5-SF7BW125</span>	<span style="border: 1px solid #ccc; padding: 2px;">0-SF12BW125</span>
<input checked="" type="checkbox"/>	2	<input style="width: 80%;" type="text" value="868.5"/>	<span style="border: 1px solid #ccc; padding: 2px;">5-SF7BW125</span>	<span style="border: 1px solid #ccc; padding: 2px;">0-SF12BW125</span>
<input type="checkbox"/>	3	<input style="width: 80%;" type="text" value="0"/>	<span style="border: 1px solid #ccc; padding: 2px;">5-SF7BW125</span>	<span style="border: 1px solid #ccc; padding: 2px;">0-SF12BW125</span>
<input type="checkbox"/>	4	<input style="width: 80%;" type="text" value="0"/>	<span style="border: 1px solid #ccc; padding: 2px;">5-SF7BW125</span>	<span style="border: 1px solid #ccc; padding: 2px;">0-SF12BW125</span>
<input type="checkbox"/>	5	<input style="width: 80%;" type="text" value="0"/>	<span style="border: 1px solid #ccc; padding: 2px;">5-SF7BW125</span>	<span style="border: 1px solid #ccc; padding: 2px;">0-SF12BW125</span>
<input type="checkbox"/>	6	<input style="width: 80%;" type="text" value="0"/>	<span style="border: 1px solid #ccc; padding: 2px;">0-SF12BW125</span>	<span style="border: 1px solid #ccc; padding: 2px;">5-SF7BW125</span>
<input type="checkbox"/>	7	<input style="width: 80%;" type="text" value="0"/>	<span style="border: 1px solid #ccc; padding: 2px;">0-SF12BW125</span>	<span style="border: 1px solid #ccc; padding: 2px;">5-SF7BW125</span>

Save

If frequency is one of CN470/AU915/US915, you can enter the index of the channel that you want to enable in the input box, making them separated by commas.

**Examples:**

1, 40: Enabling Channel 1 and Channel 40

1-40: Enabling Channel 1 to Channel 40

1-40, 60: Enabling Channel 1 to Channel 40 and Channel 60

All: Enabling all channels

Null: Indicates that all channels are disabled

Basic
Channel

Supported Frequency : US915

Single-Channel Mode:     ? Enabled Channel Index:



Channel Index	Frequency/MHz	Channel Spacing/MHz	BW/kHz
0 - 15	902.3 - 905.3	0.2	125
16 - 31	905.5 - 908.5	0.2	125
32 - 47	908.7 - 911.7	0.2	125
48 - 63	911.9 - 914.9	0.2	125
64 - 71	903.0 - 914.2	1.6	500

**Note:**  
 64 channels numbered 0 to 63 utilizing LoRa 125 kHz BW starting at 902.3 MHz and incrementing linearly by 0.2 MHz to 914.9  
 8 channels numbered 64 to 71 utilizing LoRa 500 kHz BW starting at 903.0 MHz and incrementing linearly by 1.6 MHz to 914.2

Save

## 4.3 Data Interface Settings

### 4.3.1 Basic Settings

Device ID	<input type="text" value="6445D11266900001"/>
Reporting Interval(min)	<input type="text" value="1"/>
Data Storage	<input checked="" type="checkbox"/> 
Data Retransmission	<input checked="" type="checkbox"/> 
D2D Key	<input type="text" value="*****"/>
Change Password	<input type="checkbox"/>



Parameters	Description
Device ID	Show the SN of the device.
Reporting Interval	Reporting interval of transmitting data to network server.Default: 20mins, range: 1~1080 mins <b>Note:</b> RS232 transmission will not follow the reporting interval.
Data Storage	Disable or enable reporting data storage locally. (see section <a href="#">4.6</a> to export data)
Data Retransmission	Disable or enable data retransmission. (see section <a href="#">4.7</a> )
D2D Key	Set a unique key the same as the setting in Milesight D2D controller or agent device. The D2D Key is 5572404C696E 6B4C6F52613230313823.
Change Password	Change the password to login Toolbox.

### 4.3.2 Digital Input/Pulse Counter

UC300 supports 4 digital inputs and every input can work as either digital input mode to detect high/low level or pulse counter to record counting values. When working as digital input, UC300 will upload the data according to reporting interval or when status changes.



Interface Name	DI_1
Enable	<input checked="" type="checkbox"/>
Interface Type	Digital Input
Status	<input type="text"/>  <span>Fetch</span>

Interface Name	DI_2
Enable	<input checked="" type="checkbox"/>
Interface Type	Counter
Digital Filter	 <input checked="" type="checkbox"/>
Counter Values	<input type="text"/>  <span>Refresh</span> <span>Start</span> <span>Clear</span>

Interface Name	DI_1
Enable	<input checked="" type="checkbox"/>
Interface Type	Digital Input
Status	<input type="text"/>  <span>Fetch</span>

Interface Name	DI_2
Enable	<input checked="" type="checkbox"/>
Interface Type	Counter
Digital Filter	 <input checked="" type="checkbox"/>
Counter Values	<input type="text"/>  <span>Refresh</span> <span>Start</span> <span>Clear</span>
Modify the count values	<input type="text"/>

Parameters	Description
Enable	Enable digital input to detect status and upload the data.
<b>Digital Input</b>	
Fetch	Click to get the current input status.
<b>Counter</b>	
Digital Filter	It's recommended to enable when pulse period is greater than 250 us.
Start/Stop	Click to start/stop counting. <b>Note that UC300 will send non-changeable counting values if you do not click Start.</b>
Refresh	Refresh to get latest counter values.
Clear	Count the value from 0.
Modify the	Set the initial counting value.



Enable	<input checked="" type="checkbox"/>
Stop Bit	1 bits
Data Bit	8 bits
Parity	None
Baud Rate	9600
Execution Interval (ms)	50
Max Resp Time (ms)	500
Max Retry Times	3
Modbus RS485 bridge LoRaWAN	<input checked="" type="checkbox"/>
Port	0

Parameters	Description
Enable	Allow the device to collect RS485 data and upload the data.
Stop Bit	1 bit/2 bit are available.
Data Bit	8 bit is available.
Parity	None, Odd and Even are available.
Baud Rate	1200/2400/4800/9600/14400/19200/38400/57600/115200 are available.
Execution Interval (ms)	The execution interval between each Modbus channel command.
Max Resp Time (ms)	The maximum response time that the UC300 waits for the reply to the command. If it does not get a response after the max response time, it is determined that the command has timed out.
Max Retry Times	Set the maximum retry times after device fails to read data from RS485 terminal devices.
Modbus RS485 bridge LoRaWAN	If this mode is enabled, the device will transmit Modbus RTU commands from network server to RS485 terminal devices transparently and send Modbus reply originally back to the network server. <b>Port:</b> Select from 2-84, 86-223.
Pass-through Mode	Select pass-through mode when <b>Modbus RS485 bridge LoRaWAN</b> is enabled. <b>Active Pass-through:</b> network server can send any type of command to

RS485 device and RS485 device can only react according to server commands.

**Two-way Pass-through:** not only can network server send any type of command to RS485 device, but also RS485 device supports transmitting the data to the network server actively.

**Note:** When **Two-way Pass-through** is enabled, Modbus channels can't be used and corresponding IF-THEN command will not work.

3. Click  to add Modbus channels, then save configurations.

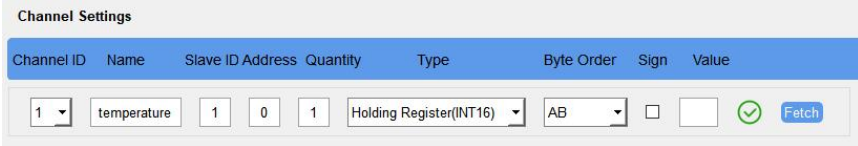
Parameters	Description
Channel ID	Select the channel ID you want to configure from 32 channels.
Name	Customize the name to identify every Modbus channel.
Slave ID	Set Modbus slave ID of terminal device.
Address	The starting address for reading.
Quantity	Set read how many digits from starting address. It fixes as 1.
Type	Select data type of Modbus channels.
Byte Order	Set the Modbus data reading order if you configure the type as Input register or holding register. This will affect the uplink order and for details refer to <b>UC300 LoRaWAN® Communication Protocol</b> . INT32/Float: ABCD, CDBA, BADC, DCBA INT16: AB, BA
Sign	The tick indicates that the value has a plus or minus sign.
Fetch	After click, UC300 will send Modbus read command to test if it can read correct values. <b>Example:</b> the device will send command as below setting: 01 03 00 00 00 01 84 0A 
Fetch All	Click to fetch all configured channels.

4. Click **Fetch** to check if UC300 can read correct data from terminal devices.

4 C 1 0 1 Input Register(INT16) AB 21 Fetch

**Note:** Do not click **Fetch** frequently since response time to reply is differ for every terminal device.

#### 4.3.5 RS232

UC300 has one RS232 interface for transparent communication. Usually it will use different tunnels from other data interfaces to communicate with server.

Enable	<input checked="" type="checkbox"/>
Baud Rate	9600
Stop Bit	1 bits
Data Bit	8 bits
Parity	None
Packet Length (byte)	256
Serial Frame Interval (ms)	100
Port	86

Parameters	Description
Baud Rate	1200/2400/4800/9600/14400/19200/38400/57600/115200 are available.
Data Bit	8 bit is available.
Stop Bit	1 bit/2 bit are available.
Parity	None, Odd and Oven are available.
Packet Length (byte)	When the device receives RS232 data up to this length, it will fragment it as a single packet and send to network server.
Serial Frame Interval (ms)	The interval that the device sends out real serial data stored in the buffer area to public network. The range is 10-65535 milliseconds. <b>Note:</b> data will be sent out when real serial data size reaches the preset packet size, even though it's within the serial frame interval.
Port	Send or receive RS232 data from this port, this port should different from the Application port. <b>Range:</b> 2-84, 86-223.

### 4.3.6 Analog Input

UC300 has two 4-20mA analog inputs and two 0-10V analog inputs for analog device connection.

After wirings, you can click **Fetch** to check if the value is correct.

Interface Name	<span>?</span> 4-20mA_1
Enable	<input checked="" type="checkbox"/>
Osh	<input type="text" value="20.00"/>
Osl	<input type="text" value="4.00"/>
Unit	<input type="text" value="mA"/>
Status	<input type="text" value=""/> <span>✓</span> <span>Fetch</span>

Interface Name	<span>?</span> 0-10V_1
Enable	<input checked="" type="checkbox"/>
Osh	<input type="text" value="10.00"/>
Osl	<input type="text" value="0.00"/>
Unit	<input type="text" value="V"/>
Status	<input type="text" value="0.00V"/> <span>✓</span> <span>Fetch</span>

**Note:** analog input scaling formula

$$Ov = [(Osh - Osl) * (Iv - Isl) / (Ish - Isl)] + Osl$$

This can also be rewritten as:

$$Ov = [(Osh - Osl)/(Ish - Isl)/(Ish - Isl)] + Osl$$

The variables are pertinent to the scaling formula:

Ov = scaled output value

Iv = analog input value

Osh = high limit of the scale for the scaled output value

Osl = low limit of the scale for the scaled output value

Ish = high limit of the scale for the analog input value

Isl = low limit of the scale for the analog input value

For example, a analog wind sensor can us 4-20mA to point to 0-32 m/s, the corresponding variables are: Osh=32 m/s, osl=0 m/s, Ish=20mA, Isl=4mA.

When it measures 6mA, the real wind speed is  $Ov = [(32 - 0) * (6 - 4) / (20 - 4)] + 0 = 4$  m/s.

### 4.3.7 PT100

UC300 has two PT100 inputs for analog device connection. After wirings, you can click **Fetch** to check if the value is correct.

**Note:**

- 1) The temperature unit in the reporting package is fixed as °C.
- 2) Please modify the command IF condition threshold settings if you change the temperature unit.

Interface Name	PT100_1
Enable	<input checked="" type="checkbox"/>
Unit	°C
Status	<input type="text"/> <input checked="" type="checkbox"/> <a href="#">Fetch</a>

## 4.4 IF-THEN Command

UC300 supports configuring locally IF-THEN commands to do some actions automatically even without network connection. One device can be added 16 commands at most.

1. Go to **Command** page, click **Edit** to add commands.

**Settings >**

ID	Configuration	Edit	Delete
1	If pt100(pt100_2) is above 35.00 continued for 0s. then do_1 will be normally open in 0s and it will last for 0s .		
2			
3			

[Save](#)

### Configuration for command NO.2

**If**

Is continued for

Set lockout time

2. Set a IF condition based on the terminal device data or UC300 device status. Users can add at most 2 conditions in one command.

Condition	Description
Time	Set the time condition. You can sync the time manually on <b>Status</b> page.
Digital Input	When UC300 device detects the DI as a specific status. <b>Is continued for:</b> the DI changed status should last for some time. <b>Set lockout time:</b> after the lockout time, UC300 will detect if DI status matches the condition. 0 means this IF condition will only be detected once.
Counter	When pulse counter reaches a specific value. This only works when DI works as counter mode.
Channel/4-20mA/0-10V/PT100	When the value reaches any threshold. <b>Is continued for:</b> the analog value should last for some time. <b>Set lockout time:</b> after the lockout time, UC300 device will detect if analog value matches the condition. 0 means this IF condition will only be detected once.
Received a message	When UC300 device receive a HEX format specific message from server.
The Device Restarts	When the device restarts.
Received a D2D control command	When the device works as a D2D agent device to receive a D2D control command. See details on <a href="#">chapter 4.5</a> .

3. Set THEN action according to your request. Users can add at most 3 actions in one command.

Action	Description						
Send a custom message	<p>Send a custom message to the server. Users can add variables on the message.</p> <p><b>Example:</b> PT100=\$T1</p> <p>The message will replace the "\$T1" as real temperature value. Corresponding variable names are shown as below:</p> <table border="1"> <thead> <tr> <th>Data Interface</th> <th>Variable Name</th> </tr> </thead> <tbody> <tr> <td>DI 1/2/3/4</td> <td>\$DI1, \$DI2, \$DI3, \$DI4</td> </tr> <tr> <td>Counter 1/2/3/4</td> <td>\$C1, \$C2, \$C3, \$C4</td> </tr> </tbody> </table>	Data Interface	Variable Name	DI 1/2/3/4	\$DI1, \$DI2, \$DI3, \$DI4	Counter 1/2/3/4	\$C1, \$C2, \$C3, \$C4
Data Interface	Variable Name						
DI 1/2/3/4	\$DI1, \$DI2, \$DI3, \$DI4						
Counter 1/2/3/4	\$C1, \$C2, \$C3, \$C4						

	DO 1/2	\$DO1, \$DO2
	4-20mA 1/2	\$A1, \$A2
	0-10V 1/2	\$V1, \$V2
	PT100 1/2	\$T1, \$T2
	RS485 Channel 1/2...32	\$R01, \$R02, \$R03, .....\$R31, \$R32
Output Trigger	DO can be set to normally open/normally closed/change status. <b>Delay Time:</b> this action will trigger after a specific time; <b>Duration:</b> the output status will last for a specific time, 0 means permanent.	
Restart the Device	Reboot the device.	
Send a D2D control command	The device works as a D2D controller device to send a D2D control command. See details on <a href="#">chapter 4.5</a> .	
Send a Modbus command via RS485 interface	This only works when UC300 works as D2D agent device. See details on <a href="#">chapter 4.5</a> .	

4. After setting all commands, click **Save**.

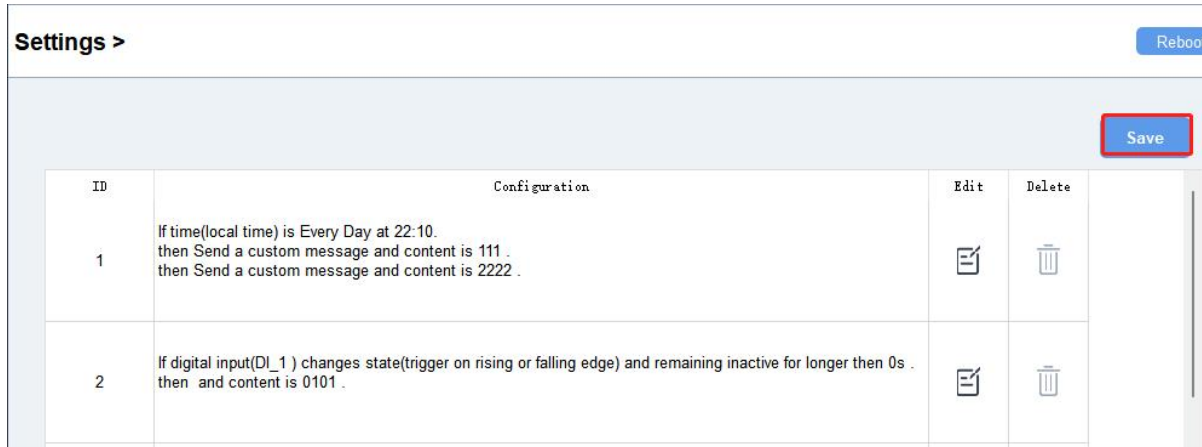

## 4.5 Milesight D2D Settings

Milesight D2D protocol is developed by Milesight and used for setting up transmission among Milesight devices without gateway. When the D2D setting is enabled, UC300 can work as a Milesight D2D controller to send control commands to other devices or work as a Milesight D2D agent to receive commands to trigger the DO or RS485 devices.

1. Go to **General > Basic** page to define a unique D2D key which is the same as D2D controller or agent devices. (Default D2D Key: 5572404C696E6B4C6F52613230313823)

The screenshot shows the 'Basic' configuration tab with the following fields:

Device ID	6445D1126690001
Reporting Interval(min)	10
Data Storage	<input type="checkbox"/>
D2D Key	*****
Change Password	<input type="checkbox"/>

2. Go to **LoRaWAN Settings > Basic** to configure the RX2 datarate and RX2 frequency. When UC300 works as Milesight D2D controller, it will send commands as RX2 settings.

The screenshot shows the 'Channel' configuration tab with the following fields:

Device EUI	24E124445D112669
App EUI	24E124C0002A0001
Application Port	85
Join Type	OTAA
LoRaWAN Version	V1.0.2
Class Type	Class C
Application Key	*****
RX2 Data Rate	DR0 (SF12, 125 kHz)
RX2 Frequency	505300000

3. Go to **Command** page to set corresponding operations.

When DI triggers, UC300 can work as D2D controller to send control command to control the D2D agent device. The command should be a 2-byte hexadecimal number.

**Configuration for command NO.1**

**If** Digital Input

DI 1 (+) (-)

goes active (rising edge-triggered)

Is continued for 0 s

Set lockout time (?)

**Then** Send a D2D control command (+)

**Content is** 0001

When UC300 receives a D2D command, it can work as a D2D agent to trigger the DO, restart the device or send Modbus command to RS485 terminal devices.

**Configuration for command NO.1**

**If** Received a D2D control command

**Containing** f001

**Then** DO 1 (+)

Will be normally open

Delay Time 0 s      Duration 0 s

**Configuration for command NO.1**

**If**

**Containing**

**Then**

**Content is**

## 4.6 Data Storage

UC300 supports storing 1,000 data records locally and export data via ToolBox. The device will record the data according to reporting interval even not joining to network.

1. Go to **Status** page to click **Sync** to sync the device time.

**Status >**

Model:	UC300-470M
Serial Number:	6445D11266900001
Device EUI:	24e124445d112669
Firmware Version:	01.01-a2
Hardware Version:	2.0
Join Status:	De-Activate
RSSI/SNR:	-110/0
Channel Mask:	00000000000000000000100
Uplink Frame-counter:	0
Downlink Frame-counter:	0
Device Time:	1970-01-01 08:27:32 <input type="button" value="Sync"/>

2. Go to **General > Basic** to enable data storage feature.

The screenshot shows the 'Basic' configuration tab for a Milesight device. The 'Data Storage' checkbox is checked and highlighted with a red box. Other fields include Device ID (6445D11266900001), Reporting Interval (10 min), Data Retransmission (unchecked), D2D Key (masked with asterisks), and Change Password (unchecked).

Field	Value
Device ID	6445D11266900001
Reporting Interval(min)	10
Data Storage	<input checked="" type="checkbox"/>
Data Retransmission	<input type="checkbox"/>
D2D Key	*****
Change Password	<input type="checkbox"/>

3. Go to **Maintenance > Backup and Reset**, click **Export** to select the data time period and click **Save** to export data.

The screenshot shows the 'Maintenance > Backup and Reset' section. The 'Export Historical Data' button is highlighted with a red box. A modal dialog box titled 'ToolBox\_v7' is open, showing 'Start' and 'End' date and time pickers. The 'Start' date is 2023/6/13 21:24 and the 'End' date is 2023/6/20 21:24. The 'Save' button in the dialog is also highlighted with a red box.

Option	Action
Config Backup	Export
Config File	Browse / Import
Export Historical Data	Export
Historical data clearing	Clear
Restore Factory Defaults	Reset

Modal Dialog: ToolBox\_v7

Field	Value
Start	2023/6/13 21:24
End	2023/6/20 21:24

4. Click **Clear** to clear all stored data inside the device if necessary.

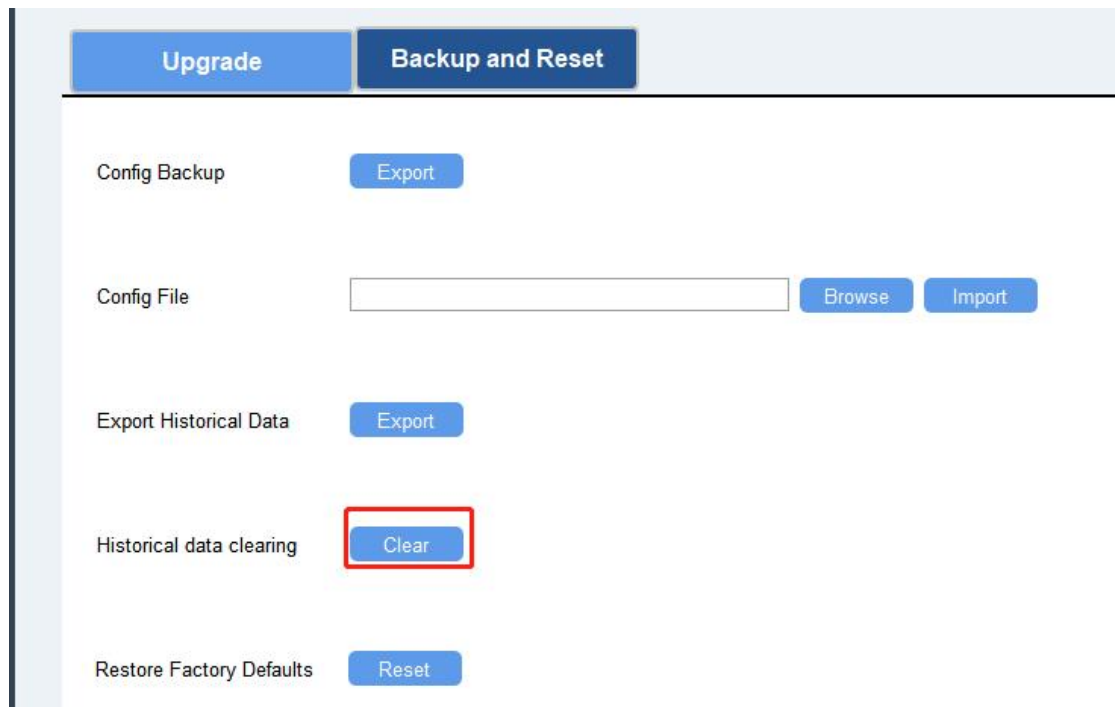

## 4.7 Data Retransmission

UC300 supports data retransmission to ensure the network server can get all data even if network is down for some times. There are two ways to get the lost data:

- Network server sends downlink commands to enquire the historical data for specifying time range, refer to **UC300 LoRaWAN<sup>®</sup> Communication Protocol**.
- When network is down if no response from LinkCheckReq MAC packets for a period of time, the device will record the network disconnected time and re-transmit the lost data after device re-connects the network.

Here are the steps for retransmission:

1. Go to **General > Basic** to enable data storage and data retransmission feature.

**General >**

Basic Digital Input Digital Output RS485

Device ID 6445D11266900001

Reporting Interval(min) 10

Data Storage  ?

Data Retransmission  ?

D2D Key \*\*\*\*\*

Change Password

Save

2. Go to **LoRaWAN Settings > Basic** to enable rejoin mode feature and set the number of packets sent. Take below as example, the device will send LinkCheckReq MAC packets to the network server regularly to check if the network is disconnected; if there is no response for 8+1 times, the join status will change to de-active and the device will record a data lost time point(the time to join the network).

Rejoin Mode  ?

Set the number of packets sent 8 packets

3. After the network connected back, the device will send the lost data from the point in time when the data was lost according to the data re-transmission reporting interval.

**Note:**

- 1) If the device is reboot or re-powered during data retransmission, the device will re-send interrupted retransmission data again after device is reconnected back to the network.
- 2) If the network is disconnected again during data retransmission, it will only send the latest disconnection data.
- 3) UC300 supports to send downlink commands to enquire the historical data for specifying time range, refer to **UC300 LoRaWAN<sup>®</sup> Communication Protocol**.

## 4.8 Maintenance

### 4.8.1 Upgrade

1. Download firmware from Milesight website to your PC.
2. Go to **Maintenance > Upgrade**, click **Browse** to import firmware and upgrade the device.

**Note:** Any operation on ToolBox is not allowed during upgrading, otherwise the upgrading will be interrupted, or even the device will break down.

Model:	UC300-470M
Firmware Version:	01.01
Hardware Version:	2.0
Domain:	Beijing Server
FOTA:	<button>Up to date</button>
Local Upgrade	<input type="text"/> <button>Browse</button> <button>Upgrade</button>

### 4.8.2 Backup

UC300 devices support configuration backup for easy and quick device configuration in bulk. Backup is allowed only for devices with the same model and LoRaWAN® frequency band.

1. Go to **Maintenance > Backup and Reset**, click **Export** to save current configuration as json format backup file.
2. Click **Browse** to select backup file, then click **Import** to import the configurations.

Config Backup	<button>Export</button>
Config File	<input type="text"/> <button>Browse</button> <button>Import</button>
Restore Factory Defaults	<button>Reset</button>

### 4.8.3 Reset to Factory Default

Please select one of following methods to reset device:

**Via Hardware:** Open the case of UC300, hold on the reset button for more than 10s until SYS LED blinks.

**Via ToolBox Software:** Go to **Maintenance > Backup and Reset** to click **Reset**.

Upgrade	Backup and Reset
Config Backup	<input type="button" value="Export"/>
Config File	<input type="text"/> <input type="button" value="Browse"/> <input type="button" value="Import"/>
Restore Factory Defaults	<input type="button" value="Reset"/>

## 5. Device Payload

Please refer to the **UC300 LoRaWAN<sup>®</sup> Communication Protocol**; for decoders of Milesight IoT products please click [here](#).

-END-