



VS125

AI Stereo Vision People Counter

User Guide

Contents

Chapter 1. Preface	4
Chapter 2. Product Introduction	7
Overview.....	7
Packing List.....	8
Hardware Components.....	9
Power Supply.....	11
Wiring Diagram.....	12
Chapter 3. Installation	13
Installation Reference.....	13
Recommended Installation Scenarios.....	13
Detection Area Reference.....	13
Install an SIM Card (Cellular Version Only).....	17
Install the Device.....	18
Troubleshoot an Abnormal Preview after Installation.....	22
Chapter 4. Web Configuration	24
Access the Device.....	24
Check the Dashboard.....	31
Configure Rules	34
Configure Basic Counting Functions.....	34
Configure Attribute Recognition Functions.....	53
Configure Digital Output Triggering.....	65
Configure Digital Input.....	68
Configure Heat Map.....	70
Stitch Multiple Devices.....	71
Configure Communication Parameters.....	81
Configure Network Parameters.....	82
Add Data Recipients.....	91

Configure BACnet Parameters (PoE Version Only).....	96
Configure MQTT API Parameters (Cellular Version Only).....	99
Generate Reports.....	102
Configure Image Parameters.....	105
Configure Occlusion Alarm Settings.....	107
Configure Depth Sensing Calibration.....	108
Configure Video Validation.....	111
Configure System Parameters.....	114
Configure Device Parameters.....	114
Configure User Parameters.....	114
Configure Time Parameters.....	118
Configure Remote Management Parameters.....	119
Configure System Maintenance Parameters.....	121
Chapter 5. Uplink Data and Downlink Commands.....	124
Uplink Data.....	124
Uplink Data Examples for Real-Time Reporting.....	124
Uplink Data Example for Periodic Reporting.....	132
Uplink Data Examples for Alarm Reporting.....	138
MQTT API Commands.....	141
Chapter 6. Services.....	151

Chapter 1. Preface

Copyright Statement

This guide may not be reproduced in any form or by any means to create any derivative such as translation, transformation, or adaptation without the prior written permission of Xiamen Milesight IoT Co., Ltd (Hereinafter referred to as Milesight).

Milesight reserves the right to change this guide and the specifications without prior notice. The latest specifications and user documentation for all Milesight products are available on our official website <http://www.milesight.com>.

Safety Instruction

Milesight will not shoulder responsibility for any loss or damage resulting from not following the instructions of this operating guide.



Warning:

Serious injury or death may be caused if any of these warnings is neglected.

- Ensure that the device is installed by a qualified personnel in strict compliance with local electrical safety regulations.
- To avoid fire and electric shock, keep the device away from rain and moisture before installation.
- Do not touch hot surfaces.
- Make sure the power plug is firmly inserted into the socket.
- Make sure the device is firmly fixed.
- Do not disassemble or remodel the device in any way.



CAUTION:

Injury or equipment damage may be caused if any of these cautions is neglected.

- Do not operate the device outside its specified temperature range.
- Do not subject the device to shock or impact.
- Avoid operating the device in environments with laser equipment.
- Ensure adequate ventilation around the device to prevent overheating.



- Use a soft dry cloth to clean the lens. For stubborn stains, dampen the cloth with a mild detergent solution, clean the lens, and immediately dry it thoroughly.
- Do not use volatile solvents such as alcohol, benzene or thinners as they may damage the device surface.

Gender Recognition Statement

Milesight respects and embraces all dimensions of diversity, including gender identity anywhere along or beyond the spectrum of gender expression.

For technical reasons, the algorithm embedded in the device recognizes only discernible visual features for gender classification (female/male). A reliable detection of the biological sex of a person is neither possible nor intended. We fully acknowledge and respect that gender is a personal identity, and our technical output is not intended to disregard or invalidate it.

Revision History

Data	Doc Version	Description
Jul. 17, 2024	V1.0	Initial version
Sep.30, 2024	V1.1	<ol style="list-style-type: none"> 1. Add Multi-Device Stitching; 2. Add Staff Detection; 3. Add Group Counting; 4. Add Heatmap; 5. Support TCP/IP Communication for cellular version.
Jan.4, 2025	V1.2	<ol style="list-style-type: none"> 1. Add configuration of Wi-Fi passwords at login, user passwords are required to contain 4 styles. 2. Add Validation. 3. Add U-turn automatic filtering. 4. Add Record Track Start/Stop Points and show Static Track Line. 5. Add I/O Settings. 6. Add Obstacle Exclusion and Detection Mode Select. 7. Support Individual Filter of Group Counting.

Data	Doc Version	Description
		<ul style="list-style-type: none"> 8. Supports automatic replacement of device information when subscribing to a topic. 9. Add LED indicator switch and diagnostic function. 10. Modify the display style of real-time track line and preview layout. 11. Modify field of view angle. 12. Remove the HTTP access feature.
Jun. 30, 2025	V1.3	<ul style="list-style-type: none"> 1. Add View Direction Detection. 2. Add Staff Badge and Staff Epaulet. 3. Modify the display style of preview layout and Dashboard. 4. Optimize the interface for displaying the Recording Space in Validation.
Sept. 22, 2025	V1.4	Add VS125-LW Version.
Mar. 10, 2026	V1.5	<ul style="list-style-type: none"> 1. Remove all references to the VS125-LW model. This guide applies only to the VS125 model. 2. Support Digital Input. 3. Support Frame Non-overlapping in multi-device stitching. 4. Add OpenVPN communication. 5. Add Occlusion Detection. 6. Add Depth Sensing Calibration. 7. Add cooldown period for trigger reports. 8. Add Real-time Data Report. 9. Add device display information in Dashboard. 10. Support modify privacy mode in system management. 11. Support modify PLMN and DNS server manually. (VS125-Cellular Only) 12. Add EAP-TLS authentication type in 802.1x communication. (VS125-P Only) 13. Add the password for the HTTPS direct installation certificate key. (VS125-P Only) 14. Support BACnet protocol. (VS125-P Only)

Chapter 2. Product Introduction

This chapter describes basic product information.

Overview

VS125 is a professional people counting sensor that uses deep learning AI and binocular stereo vision technology. It possesses an impressive people counting accuracy of up to 99.8% and maintains reliable performance even in low-light environments and total darkness. Besides, it supports attributes recognition including gender, children and staff. It features a privacy-by-design architecture and complies with the GDPR.

VS125 supports cellular and PoE interfaces for network access and RS485, DO and DI interfaces for external device integration. Its simple installation process makes it suitable for multiple applications such as retail stores, malls, offices, and subway stations.

The device has the following features:

- **Reliable performance:**
 - Up to 99.8% people counting accuracy with AI and stereo vision technology.
 - Maintains stable performance in diverse lighting conditions, even in pitch darkness.
- **Installation flexibility & Auto-Calibration Technology:**
 - Supports high ceiling mounting up to 6 m, providing greater deployment flexibility for various environments.
 - Supports automatic tilt correction and infrared adjustment to maintain optimal detection performance.
- **Various functions:**
 - Supports line crossing people counting, regional people counting and dwell time detection.
 - Supports attribute recognition including gender, group counting, children, staff identification to provide deeper insights.
 - Supports the heat map function for analyzing foot traffic intensity and distribution.
 - Supports multi-device stitching. Up to 16 device can be stitched to expand the coverage area.
- **Multiple interfaces:**
 - Provide multiple connectivity options (PoE, Cellular).
 - Supports RS485, DI and DO interfaces for external device integration.
 - High compatibility of data transmission with HTTP(s)/MQTT(s) protocol and API, supports customized push content methods.
- **Device management and data security:**

- Quick and simple management through the Milesight Devicehub and Milesight Development Platform.
- Customer-defined preview privacy settings. No personal information is transmitted, ensuring compliance with the GDPR.
- Supports local data storage and data retransmission for secured data collection.

Packing List

This chapter describes the packing list. You can verify the contents against the following list to ensure all items are present. If any of them is missing or damaged, you can contact your sales representative.

Universal Accessories

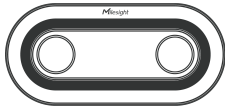

1 × VS125 Device



4 × Ceiling Mounting Kits



1 × Multi-interface Cable



1 × Warranty Card



1 × Quick Guide

Accessories Exclusively for Cellular Version

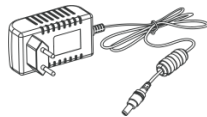

1 x Power Adapter



1 x SIM-eject Tool

Accessories Exclusively for PoE Version

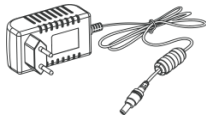

1 x Power Adapter (Optional)

The device is also compatible with multiple mounting kits and accessories that can be purchased independently. For detailed information about them, refer to [Accessories for Milesight People Counters](#).

Hardware Components

Main Components

The following figure shows the main components of the device.

Cellular Version:

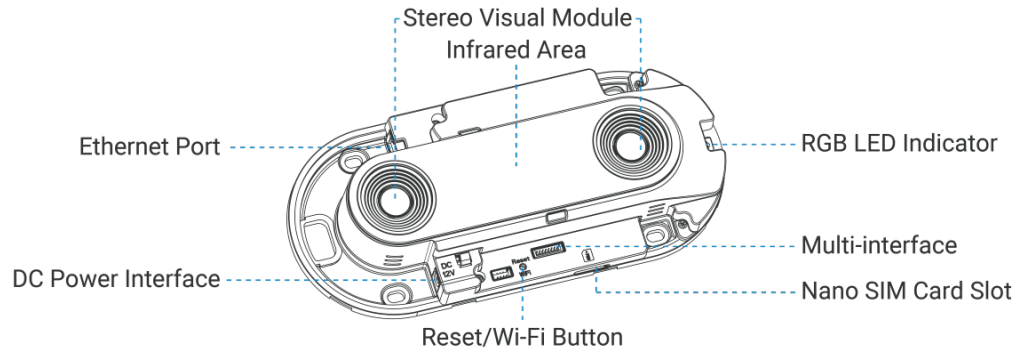

PoE Version:

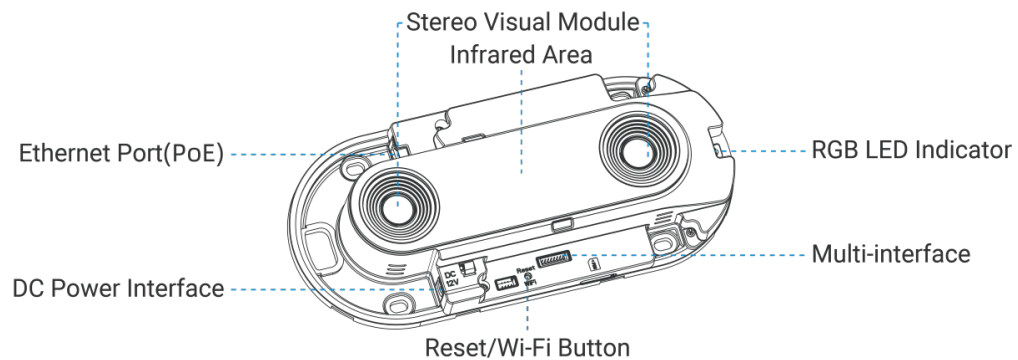

For the description of each component, refer to the following table:

Name	Description
Ethernet Port	Provides data communication and multi-device stitching capability. When Power over Ethernet (PoE) is supported, the same port can also power the device.
DC Power Interface	Provides a power input for the device by connecting to an external DC power adapter.
Stereo Visual Module	It is a dual-camera module that captures and processes stereoscopic images.

Name	Description
Infrared Area	Provides night vision capability by emitting invisible infrared light to illuminate the scene.
RGB LED Indicator	Provides visual status indications through a multi-color LED.
Multi-interface	Provides physical connection points for external devices.
Nano SIM Card Slot	Slot for inserting a Nano-SIM card to establish a cellular network connection.
Reset/Wi-Fi Button	Dual-function button for resetting the device and activating the Wi-Fi pairing mode.

Power Button and LED Indicators

The device has a power button and an LED indicator for Wi-Fi enabling/disabling and reset functions. For the functions of the power button and the corresponding LED indicator status, refer to the following table.

Function	Action	LED Indicator
Enable/Disable Wi-Fi	Long press the power button for 3 seconds.	Enable/Disable: The blue light blinks for 3 seconds. Wi-Fi enabled: The blue light is on. Wi-Fi disabled: The green light is on.
Reset the device	Long press the power button for 10 seconds.	The green light blinks until the reset process is completed.
Module or algorithm detection error	/	The red light is on.

Dimensions

The following figure shows the device dimensions (unit: mm)

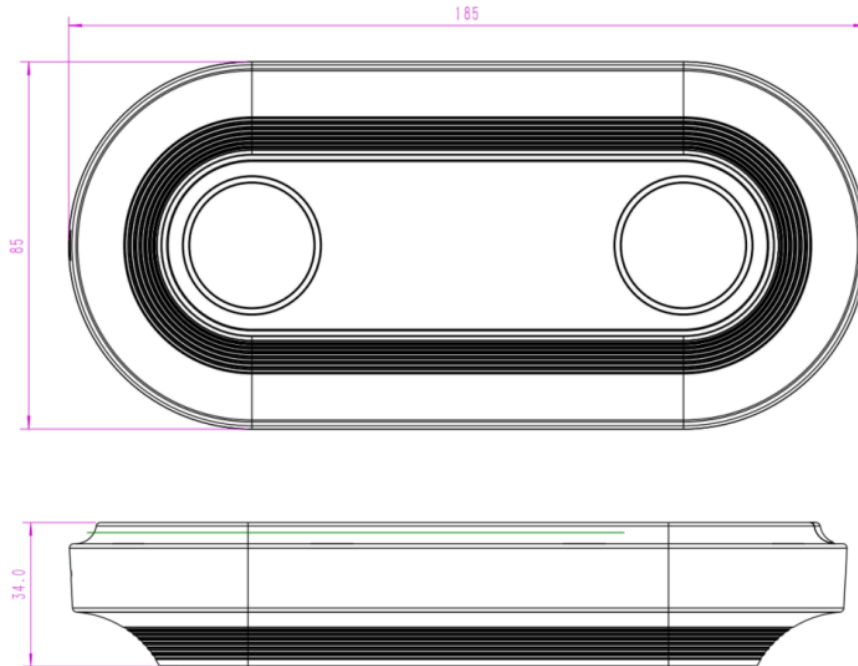

Power Supply

The device can be powered by a DC power adapter (12V, 1A).



The device can be powered by a PoE switch (802.3af compliant). This applies to the PoE version only. The length of the Ethernet cable crystal head must be less than 40 mm.



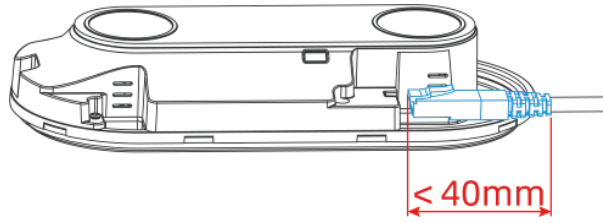

Wiring Diagram

This following figure shows the wiring diagram.

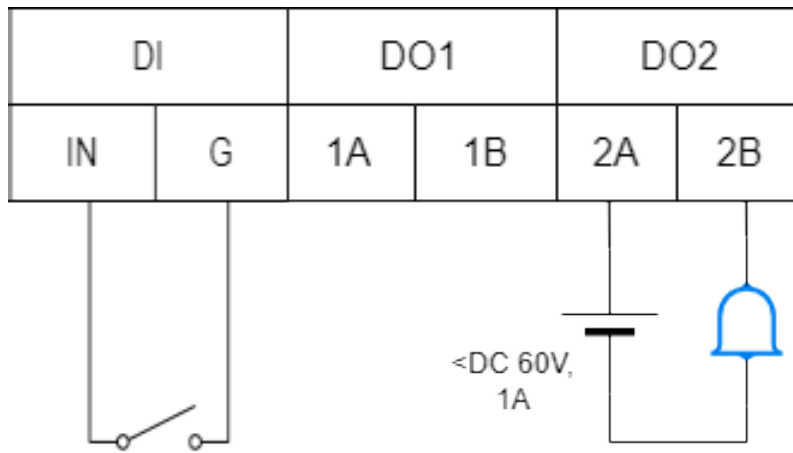

DI: By default, two connected contacts = low level, two disconnected contacts = high level.

DO: Loads up to 1A@60V DC.

Chapter 3. Installation

Installation Reference

This section describes the recommended installation scenarios, the factors affecting accuracy and the detection area.

Recommended Installation Scenarios

The following table lists application scenarios recommended and not recommended of the device. The device applies for many scenarios. The table lists only typical application examples. For scenarios not listed, contact Milesight for details.

Recommendation	Installation Scenario	Example
Recommended	Various public spaces and their entrances/exits	Shopping malls, retail stores
	Areas where space utilization needs to be optimized	Offices, libraries
	Areas requiring personnel scheduling and management	Train stations, airports
Not Recommended	Locations where the device may be exposed to rain	Parks
	Private areas	Bathrooms

Detection Area Reference

The following table describes detection area calculation related parameters.

One device Unit

Table 1. Parameter Definition

Parameters	Description	Value
H	Installation height	2.2 - 6 m If attribute identification is required, refer to the following table for the installation height requirements:

Parameters	Description	Value	
		Attribute Identification	Installation height
		Children&Adult Differentiation	2.2 - 4m
		Gender Recognition	2.2 - 4m
		Staff Detection	2.2 - 4m
		Group Counting	2.2 - 6 m
		View Direction Detection	2.2 - 4m
h	Target height	Example 1.7 m	
α	Horizontal field of view angle	101°	
β	Vertical field of view angle	70°	
x	Detection range length	$2 \times \tan(\alpha/2) \times (H-h+0.05)^*$	
y	Detection range width	$2 \times \tan(\beta/2) \times (H-h+0.05)^*$	

* The "+0.05" in the formula accounts for the device's mounting offset from the ceiling surface.

The detection area depends on the device's field of view angle, installation height, and target height. The following figure uses the horizontal field of view angle, an installation height of 3 meters, and a target height of 1.75 meters as an example for illustration.

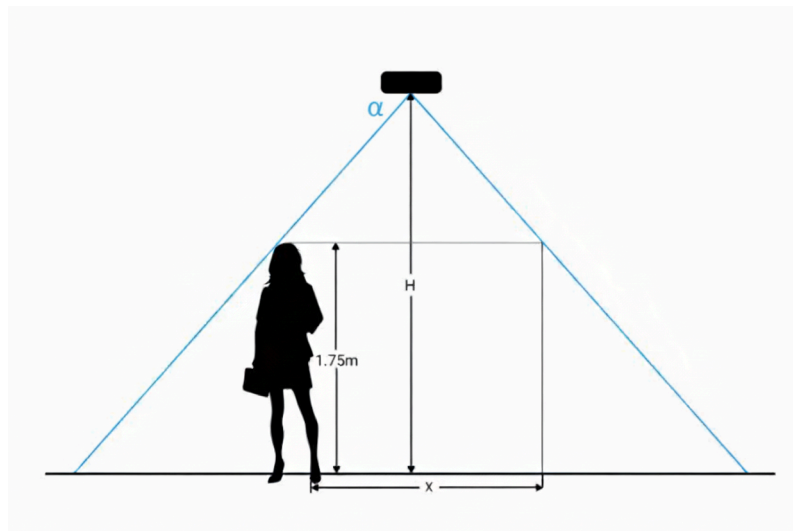

Example: For a 1.75 m target height, the detection area for each installation height is as follows:

Table 2. Detection Area

Installation Height	Detection Area
2.2 m	$1.21 \times 0.7 \text{ m}^2$
2.5 m	$1.94 \times 1.12 \text{ m}^2$
3.0 m	$3.16 \times 1.82 \text{ m}^2$
3.5 m	$4.37 \times 2.52 \text{ m}^2$
4.0 m	$5.58 \times 3.22 \text{ m}^2$
4.5 m	$6.80 \times 3.92 \text{ m}^2$
5.0 m	$8.01 \times 4.62 \text{ m}^2$
5.5 m	$9.23 \times 5.32 \text{ m}^2$
6.0 m	$10.44 \times 6.02 \text{ m}^2$

Multi device Unit

Table 3. Parameter Definition

Parameters	Description	Value
H	Installation height	2.2 - 6 m

Parameters	Description	Value												
		<p>If attribute identification is required, refer to the following table for the installation height requirements:</p> <table border="1"> <thead> <tr> <th>Attribute Identification</th> <th>Installation height</th> </tr> </thead> <tbody> <tr> <td>Children&Adult Differentiation</td> <td>2.2 - 4m</td> </tr> <tr> <td>Gender Recognition</td> <td>2.2 - 4m</td> </tr> <tr> <td>Staff Detection</td> <td>2.2 - 4m</td> </tr> <tr> <td>Group Counting</td> <td>2.2 - 6 m</td> </tr> <tr> <td>View Direction Detection</td> <td>2.2 - 4m</td> </tr> </tbody> </table>	Attribute Identification	Installation height	Children&Adult Differentiation	2.2 - 4m	Gender Recognition	2.2 - 4m	Staff Detection	2.2 - 4m	Group Counting	2.2 - 6 m	View Direction Detection	2.2 - 4m
Attribute Identification	Installation height													
Children&Adult Differentiation	2.2 - 4m													
Gender Recognition	2.2 - 4m													
Staff Detection	2.2 - 4m													
Group Counting	2.2 - 6 m													
View Direction Detection	2.2 - 4m													
h	Target height	Example 1.7 m												
α	Horizontal field of view angle of each device	101°												
β	Vertical field of view angle of each device	70°												
x	Detection range length of each devices	$x = 2 \times \tan(\alpha/2) \times (H-h+0.05)$ for each device												
y	Detection range width of each devices	$y = 2 \times \tan(\beta/2) \times (H-h+0.05)$ for each device												
a	Number of devices required along the coverage length	Coverage length \div x, Round to the nearest integer based on deployment requirements												
b	Number of devices required along the coverage width	Coverage width \div y, Round to the nearest integer based on deployment requirements												

Example: For a coverage area of 6m*3m (coverage length*coverage width) with VS125-P devices installed at 3m height (H) and 1.75m target height (h):

$x = 3.16$ m, a: Coverage length \div x = $6 \div 3.16 \approx 1.90$, a = [1.90] \approx 2 devices

$y = 1.82 \text{ m}$, b : Coverage width $\div y = 3 \div 1.82 \approx 1.65$, $b = [1.65] \approx 2$ devices

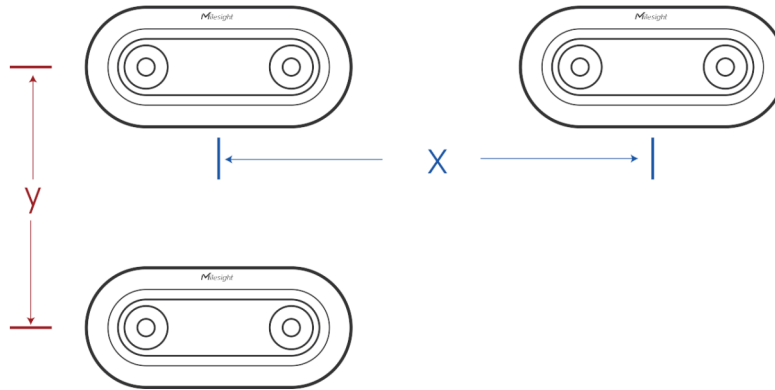

Conclusion: $2 \times 2 = 4$ devices are required for complete coverage of the $6 \text{ m} \times 3 \text{ m}$ area.

Install an SIM Card (Cellular Version Only)

This section describes how to install the SIM card, which is required for the cellular version.

Steps:

1. Remove the cover:
 - a. Place both thumbs on the infrared area.
 - b. Rest the other four fingers along the edge of the outer cover to provide support.
 - c. Using both hands, push in the direction of the arrows to remove the back cover.

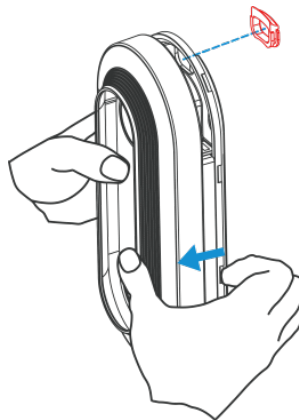

2. Use the SIM-eject tool to eject the SIM tray.

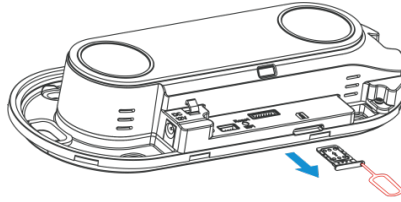

3. Place the Nano SIM card into the tray and re-insert the tray fully into the device.

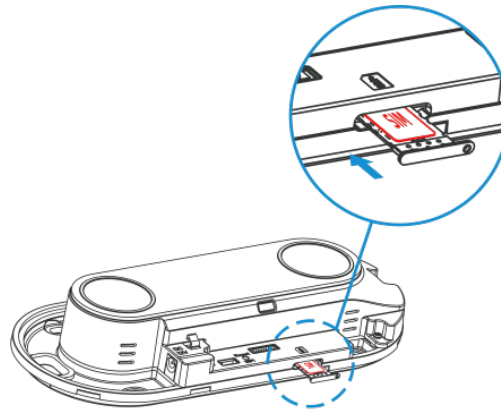

Install the Device

This section describes how to install the device to the ceiling. You can also install the device by watching the [installation video](#).

Requirements:

Area requirements:

- Areas with stable lighting and rich environmental textures (such as patterned floors or walls).
- Free from reflective surfaces (such as glass, mirrors).
- Locations with an unobstructed field of view.
- Ceiling installation above a swing door: The device should be mounted on the ceiling section above the stationary (hinge) side of the door.

Ceiling requirements: Flat ceiling, minimum thickness: 30 mm, tilt angle: $\leq 10^\circ$.

Multi-device Stitching requirements:

- Installation height: All devices must share the same height.
- Software Version: All devices must run the same software version.

- Connectivity: Supports PoE or Cellular connectivity and supports hybrid combinations.
- Stitch Method: Non-overlapping Coverage in Focus Areas or Continuous Coverage via Adjacent Installation.

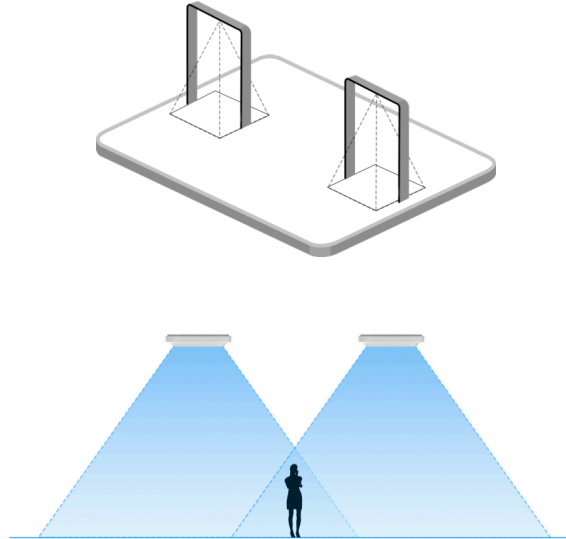

Note:

For optimal stitching, ensure that targets near the edges of both fields of view can be fully captured and detected simultaneously.

Preparations:

- Verify that the device and accessories are complete according to the [Packing List](#).
- Notify individuals and obtain consent for image collection. Inform them of opt-out rights.
- If you have purchased optional accessories, please refer to [ACCESSORIES](#) for the operating steps.

Steps:

1. Remove the cover:
 - a. Place both thumbs on the infrared area.
 - b. Rest the other four fingers along the edge of the outer cover to provide support.
 - c. Using both hands, push in the direction of the arrows to remove the back cover.

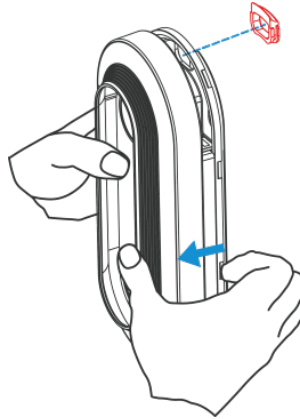

2. (Optional) To route the cables from the side of the device, remove the rubber plug.

3. Install expansion sleeves.

- a. Use a marker pen or another suitable tool to mark the drilling positions on the ceiling according to the mounting holes of the device.
- b. Drill four 4-mm holes in the ceiling according to the marked hole positions.
- c. Insert expansion sleeves into the ceiling holes.

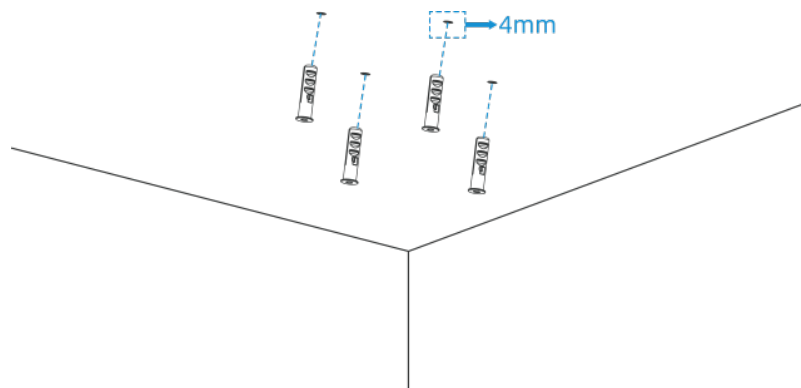

4. (Optional) To route cables through the ceiling, mark and drill a access hole at the desired location.

5. Route the cables and connect them to the device.

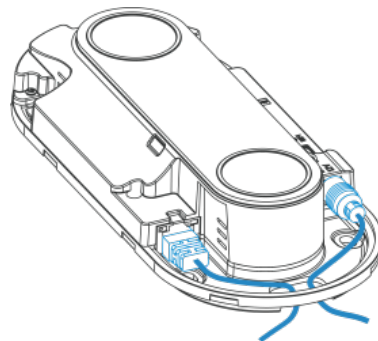

(Optional) To use the alarm I/O, the multi-interface cable must be connected to the device.

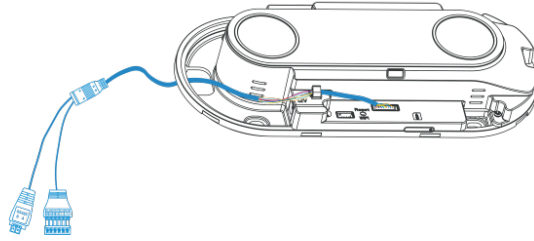

6. Secure the device to the ceiling using mounting screws.

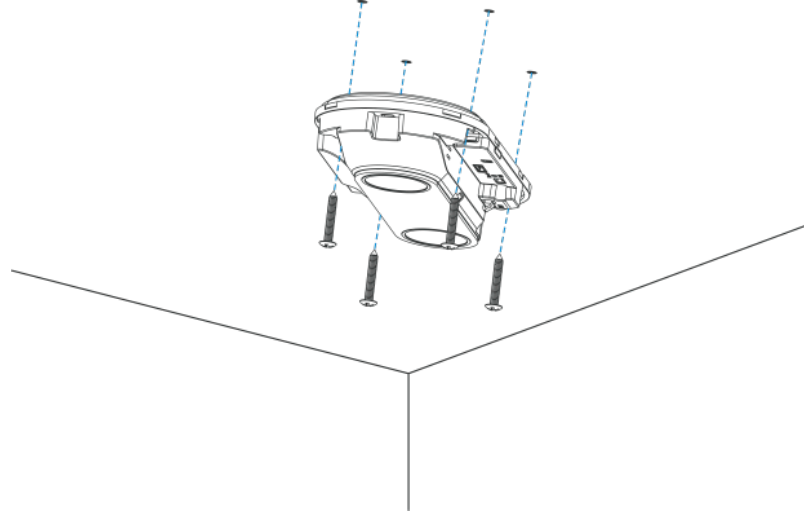

7. Remove the lens protective film.

8. Reattach the cover to the device.

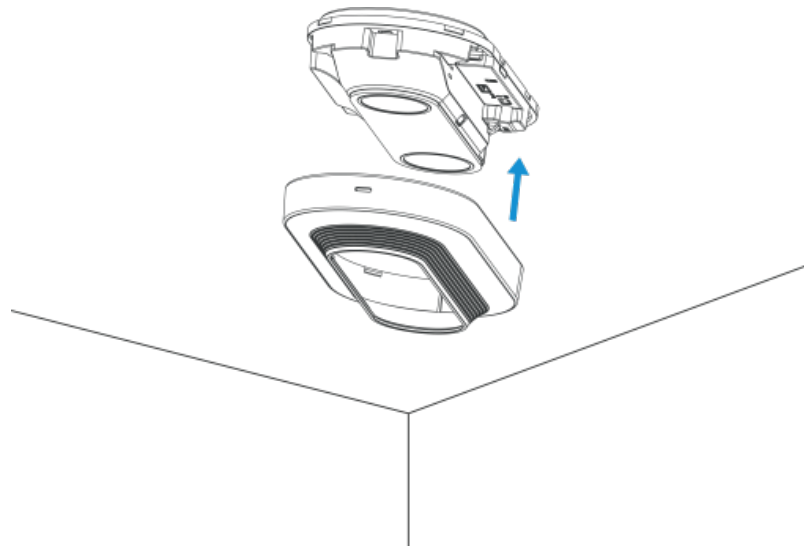

9. (Optional) For multiple device installations, repeat Steps 1 through 8.

10. [Log in to the web GUI](#) to check the preview on the **Dashboard** page.

- The display effect for a normal environment is as follows. The ground is rendered with light blue or blue spot patterns. A color gradient is applied to objects based on height, with taller objects assigned increasingly red tones.

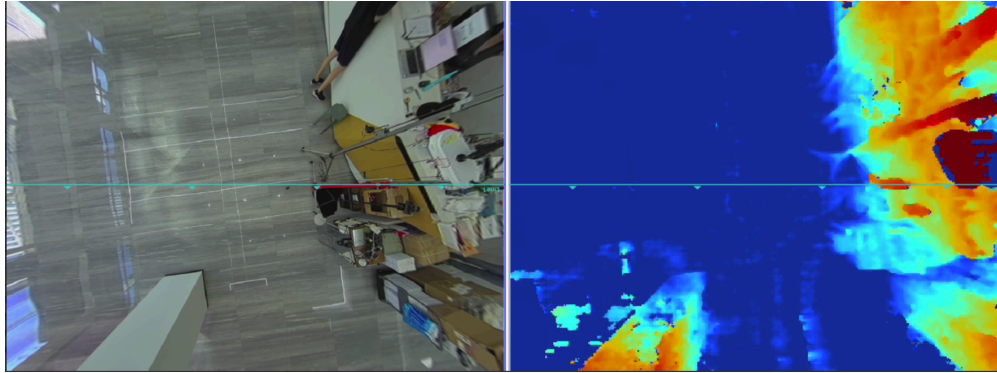

- The display effect for normal targets is as follows. The clear color gradient on detected targets indicates effective depth perception.

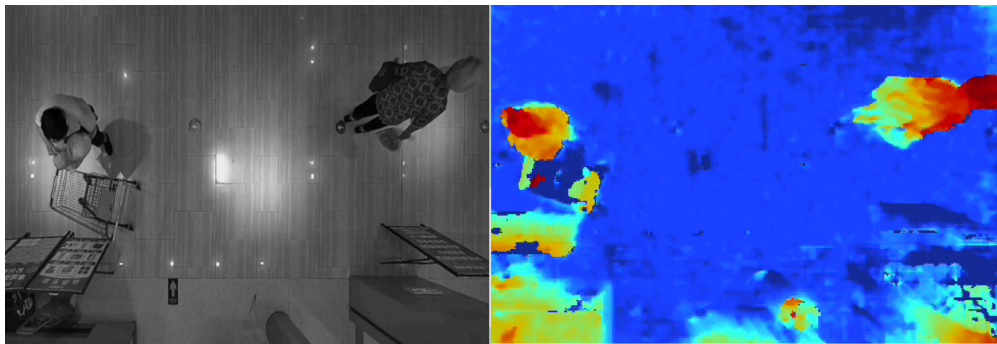

Troubleshooting:

If the preview on the **Dashboard** page is abnormal, refer to [Troubleshoot an Abnormal Preview after Installation](#) for troubleshooting.

11. (Optional) For multiple devices, verify that targets near the edges of both fields of view in adjacent devices are fully captured and detected at the same time.

Troubleshoot an Abnormal Preview after Installation

This section describes how to troubleshoot an abnormal dashboard preview after the device is installed.

Steps:

1. Verify that the lens protective film has been removed.
2. Verify that the device is installed horizontally (within $\pm 10^\circ$).

3. Identify and remove any objects (such as pendant lights, downlights) that are too close to the device or obstructing its field of view.
4. Adjust the installation height through the web GUI. For how to log in to the web, refer to [Access the Device](#).
 - a. On the **Rule** page of the web GUI, click **Detect** to use the automatically detected height value.

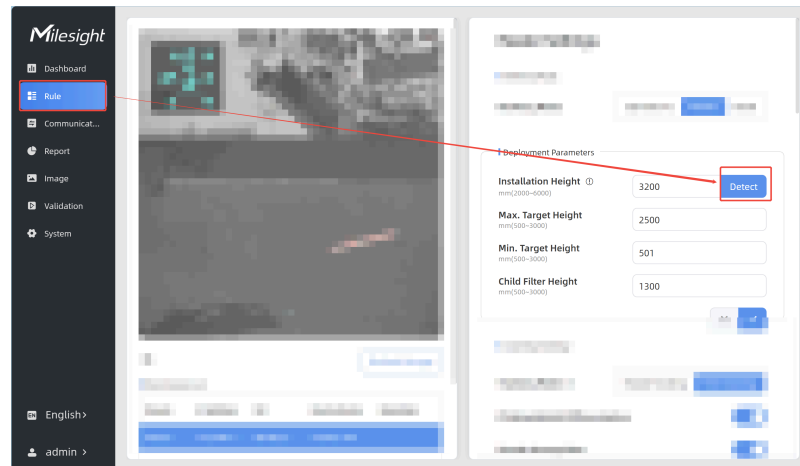

- b. Switch to the **Dashboard** page to check the preview and make the following adjustments if necessary:
 - If the depth map is predominantly blue → switch to the **Rule** page → increase the installation height by 50 mm increments (recommended).
 - If the depth map is predominantly red → switch to the **Rule** page → decrease the installation height by 50 mm increments (recommended).
5. Verify that the lens is secure and the housing is not deformed, even if no external damage is visible.
6. If the problem persists, contact your Milesight sales representative.

Chapter 4. Web Configuration

The device can be configured through the web. This section describes web configuration.

Access the Device

The device can be configured through the web GUI, which is accessible over Wi-Fi or Ethernet. This section describes how to access the device using these two methods.

Preparations: Computer and network cable

Steps:

1. Perform the following operations as needed.
 - If you access the device through the wireless network:
 - a. Enable wireless network connection on the computer.
 - b. Search for the device Wi-Fi SSID and connect it to the computer. The Wi-Fi SSID follows the format of `People Counter_xxxxxx` and is located on the physical label of the device.

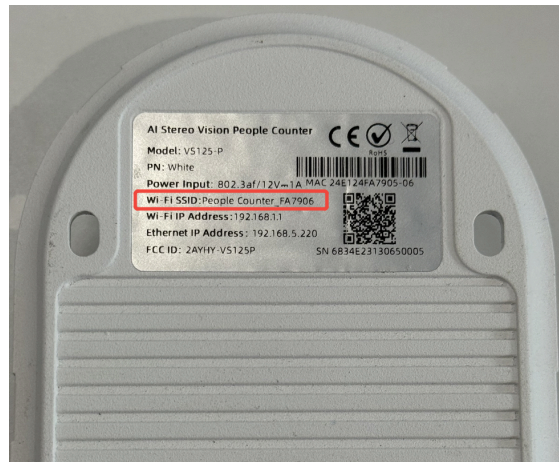



- c. Open a browser and enter Wi-Fi IP address 192.168.1.1. The **Activation** dialog box is displayed.
- If you access the device through the Ethernet port:

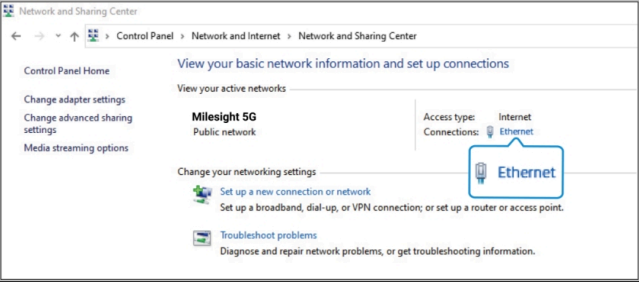

Note:

For firmware versions 1.0.5 and above, the device's IP assignment method is automatic (DHCP) by default.

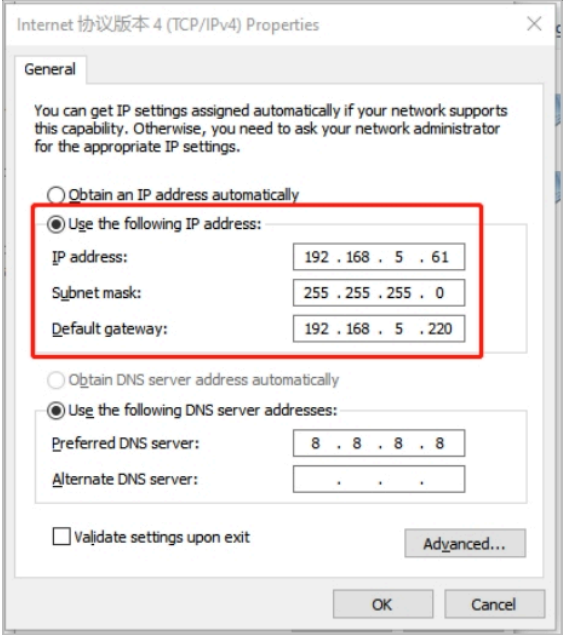
IP Assignment Method	Description
<p>Automatic (DHCP)</p>	<p>a. Connect the computer and the device to a DHCP server (such as a router or switch) using the network cable.</p> <p>b. Check the current IP address of the device using any of the following methods:</p> <ul style="list-style-type: none"> ▪ Log in to your DHCP server and view the DHCP client list. ▪ Use the Milesight VS tool to scan for devices on the local network. <p>c. Open a browser and enter the Ethernet IP address. The Activation dialog box is displayed.</p> <p>If the device does not obtain an IP address within 30 seconds after powering on, it will automatically revert to the static IP address: 192.168.5.220. You can access the device through Manual (Static IP).</p>
<p>Manual (Static IP)</p>	<p>a. Use the network cable to connect the device and the computer.</p> <p>b. Click Start → Control Panel → Network and Internet → Network and Sharing Center.</p>  <p>The screenshot shows the Windows Network and Sharing Center window. The breadcrumb path is 'Control Panel > Network and Internet > Network and Sharing Center'. Under 'View your active networks', 'Milesight 5G' is listed as a 'Public network'. Under 'View your basic network information and set up connections', the 'Access type' is 'Internet' and 'Connections' includes 'Ethernet'. A blue box highlights the 'Ethernet' connection. Under 'Change your networking settings', there are links for 'Set up a new connection or network', 'Set up a broadband, dial-up, or VPN connection; or set up a router or access point.', and 'Troubleshoot problems'.</p> <p>c. Click Ethernet → Properties and double click Internet Protocol Version 4 (TCP/IPv4). The Internet Protocol Version 4 (TCP/IPv4) Properties dialog box is displayed.</p>

IP Assignment Method	Description
	<div data-bbox="797 268 1357 898" style="border: 1px solid gray; padding: 10px; margin-bottom: 20px;">  </div> <p>d. Click Use the following IP address.</p> <p>e. In the Use the following IP address area, perform the following operations.</p> <ol style="list-style-type: none"> i. Enter an IP address (such as 192.168.5.61) that is in the same subnet as the device. <div data-bbox="813 1192 1419 1367" style="border: 1px solid gray; border-radius: 10px; padding: 10px; margin: 10px 0;"> <p> Note: This IP address must be unique and not used by any other device on the network.</p> </div> <ol style="list-style-type: none"> ii. Set Subnet mask to 255.255.255.0. iii. Set Default gateway to 192.168.5.220. <p>f. Click OK.</p> <p>g. Open a browser and enter Ethernet IP address 192.168.5.220. The Activation dialog box is displayed.</p>

2. Set the login password and click . The **Set Security Questions** dialog box is displayed.

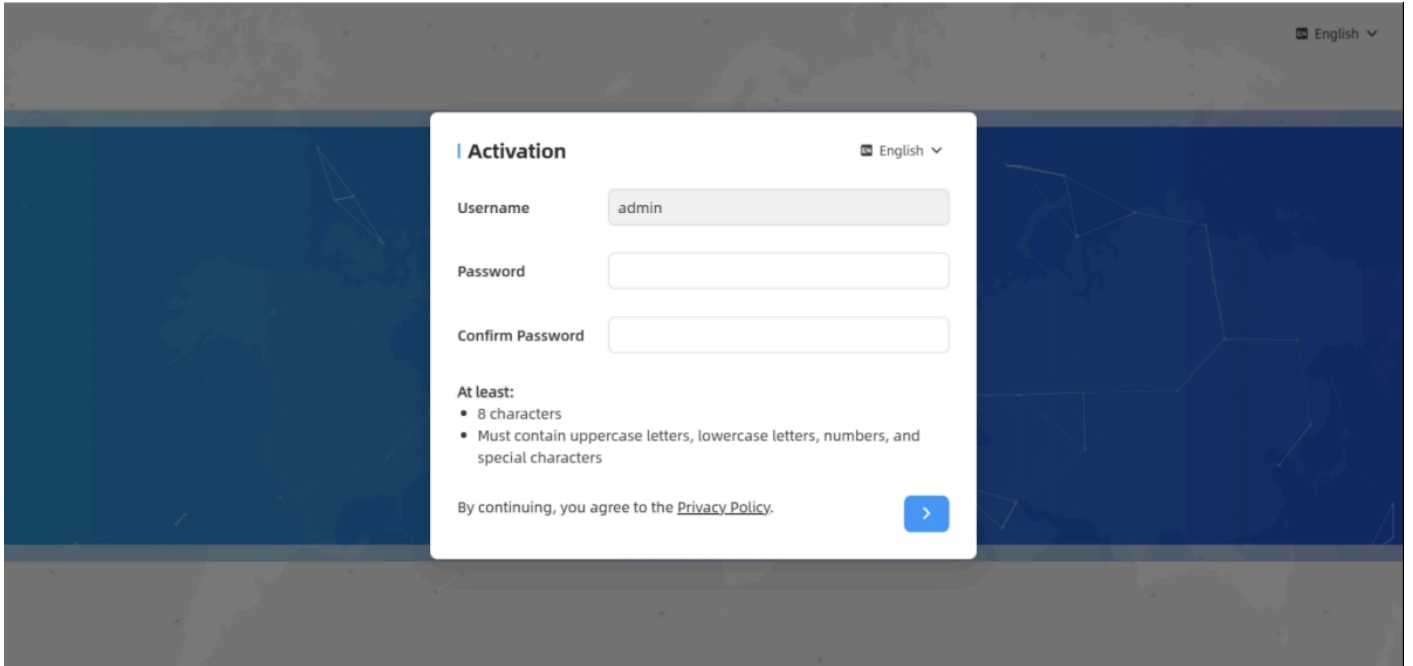

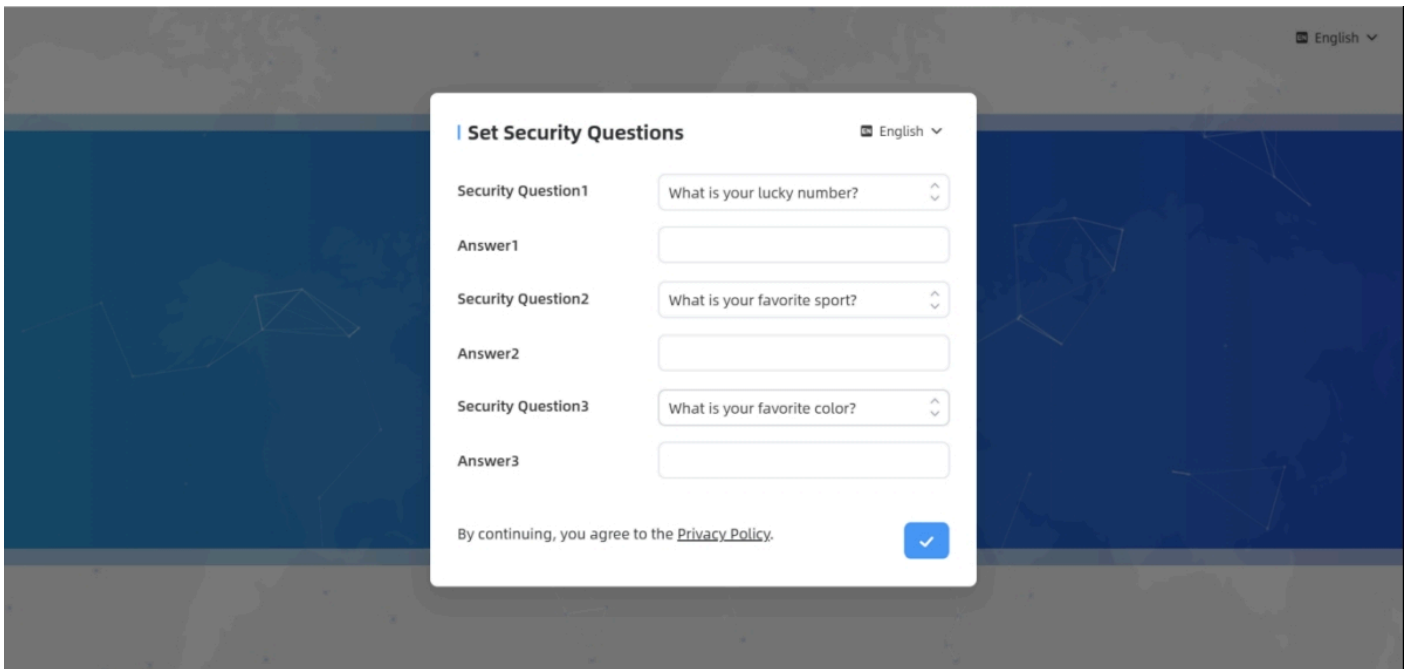

3. Set the three security questions when using the device for the first time and click . The **Privacy Settings** dialog box is displayed.

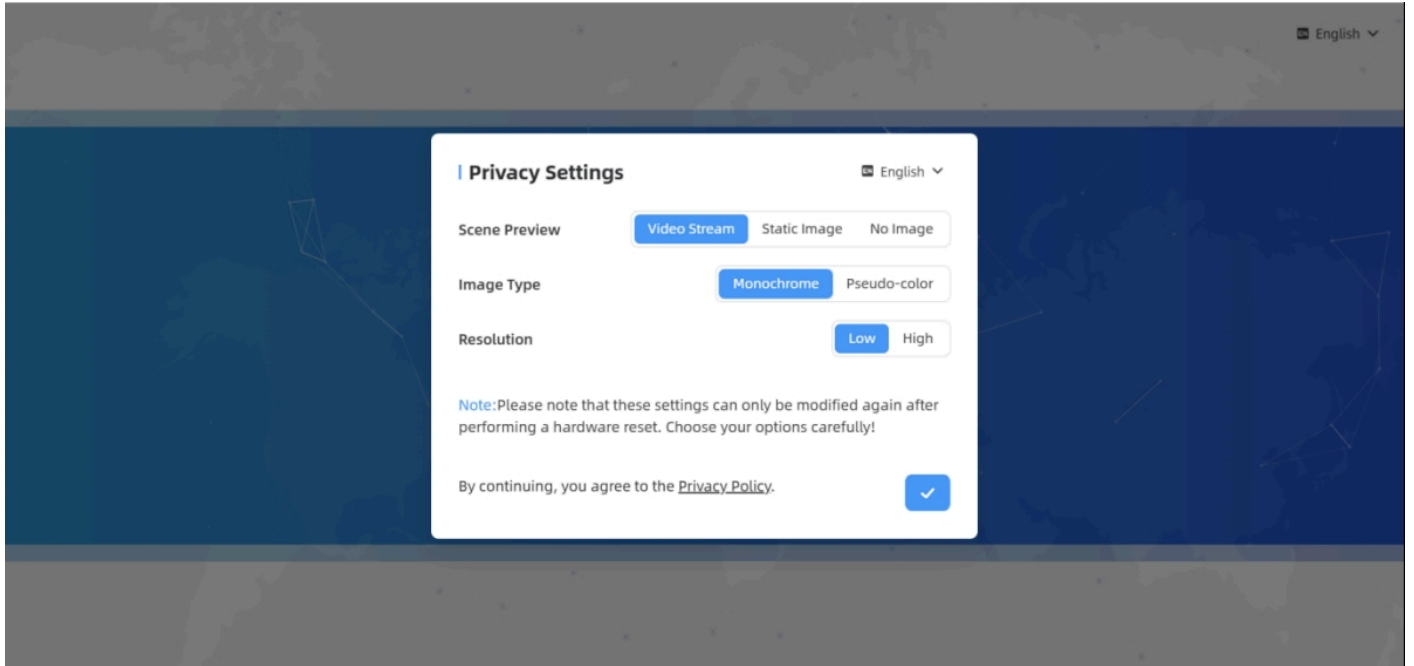

4. Configure the following parameters as needed to set the preview image on the dashboard. If you would like to switch modes in the future, please go to [Privacy Settings](#).

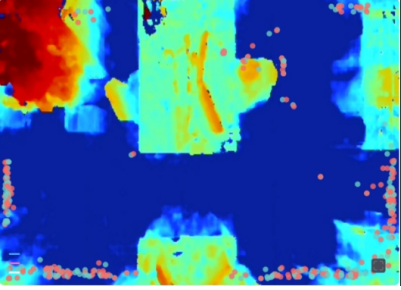

Parameters	Description
<p>Scene Preview</p>	<p>Options: Video Stream, Static Image and No Image.</p> <ul style="list-style-type: none"> - Video Stream: Live video preview of the camera's field of view. - Static Image: Still snapshot of the scene. - No Image: No image displayed.
<p>Image Type</p>	<p>Options: Monochrome or Pseudo-color.</p> <ul style="list-style-type: none"> - Monochrome: Displays the image in grayscale (black, white, and gray). <div data-bbox="805 1486 1203 1787" data-label="Image"> </div>

Parameters	Description
	<p>- Pseudo-color: Enhances image details by mapping grayscale intensities to a color spectrum.</p> 
<p>Resolution</p>	<p> Note: This parameter selection is only required for the Monochrome image type.</p> <p>Options: Low, High.</p> <p>Low: Provides a lower-quality image that uses less bandwidth, suitable for basic scene monitoring and motion detection.</p> <p>High: Provides a high-quality clear image necessary for identifying details such as facial features.</p>

5. Click  to save the configuration. The following page is displayed.

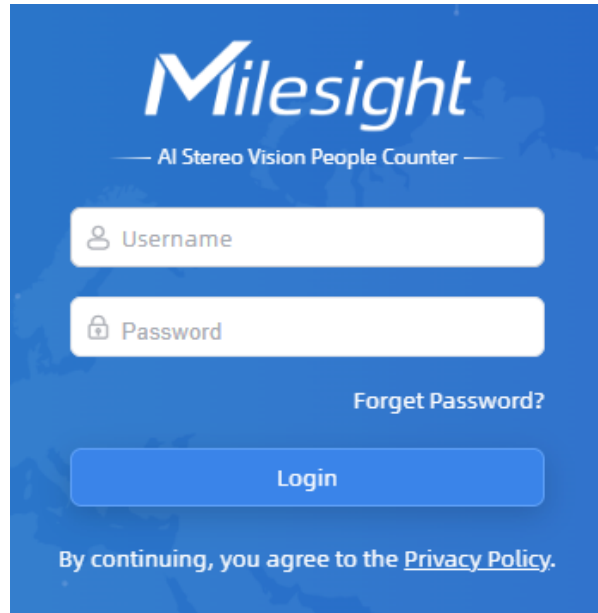

6. Enter the username (admin) and the login password. The **WLAN Settings** dialog box is displayed.

7. Set the Wi-Fi password and click  to save the configuration.

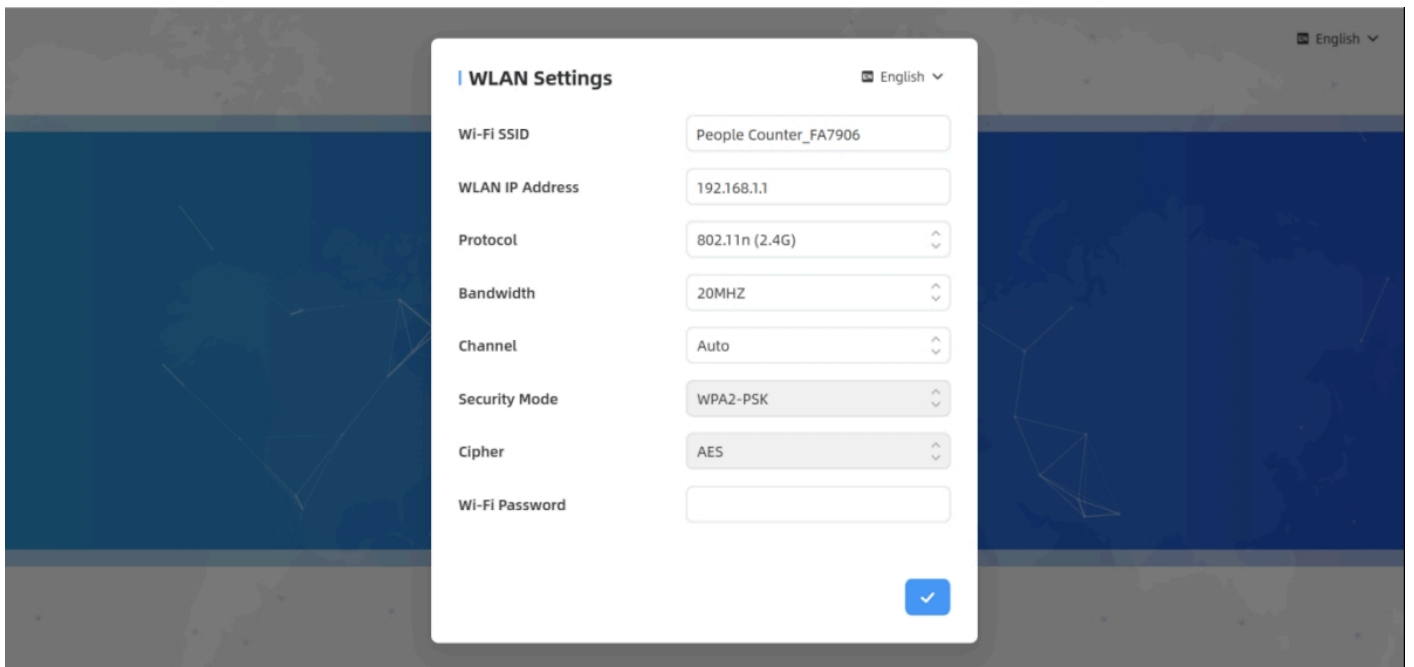

**Note:**

1. The login password and the Wi-Fi password must be 8 to 63 characters long and contain numbers, lowercase letters, uppercase letters and special characters. If the password is entered incorrectly five times, the account is locked for 10 minutes.
2. It is recommended that users regularly update the passwords to enhance device security and prevent unauthorized access.
3. You can click **Forget Password?** in the login page to reset the password by answering three security questions when you forget the password if you set the security questions in advance.

Check the Dashboard



Upon configuration of both basic counting and advanced AI recolonization functions, the device provides multiple data presentation options such as the dashboard, reports and command line outputs.



The dashboard visualizes critical data in a centralized real-time layout for at-a-glance monitoring. The master device dashboard is used as an example for description in this section.

Steps:

1. In the main page, click **Dashboard** from the left navigation tree. The **Dashboard** page is displayed.
2. Check the data or perform the operations as needed. For **Dashboard** page description, refer to the following table.



NO.	Item	Description
1	Line, Region, Attention Region, Digital Input, Device Info data display area	<p>After functions Line Cross Counting, Region Monitoring and View Direction Detection are configured, the corresponding line, region and attention region data is displayed in this area.</p> <p> Hide/Show Capacity: Hides/shows the total data counting capacity.</p> <p> Children Included/Excluded: Includes/Excludes children data from statistical data.</p> <p> Staff Included/Excluded: Includes/Excludes staff data from statistical data.</p> <hr/> <p>Digital Input: Display the current DI information when Manual DI is enabled.</p> <hr/> <p>Device Info: Display the current running information.</p>
2	Preview	Real-time video display area.

NO.	Item	Description
3	Reset Count	Clears all accumulated people counting values.
4	Digital Output	Click it to output high level signals through the multi-interface when Manual DO is enabled.
5	Edit Preview Layout	<p>Click  . The Edit Preview Layout dialog box is displayed. Select the items to be displayed in the preview as needed. The items displayed here are dependent on the functions enabled.</p> <p>Real-time Track Line: Show or hide the target's track line in the preview.</p> <p>Static Track Line: Show or hide the history of the target's track line in the preview. Up to 1000 historical track records are supported. They are cleared upon page refresh.</p> <div data-bbox="597 867 1040 1150"> <p>Visual Configuration</p> <ul style="list-style-type: none"> <input checked="" type="checkbox"/> Detection Line <input checked="" type="checkbox"/> U-turn Area <input checked="" type="checkbox"/> Detection Region <input checked="" type="checkbox"/> View Direction Related Region <p>AI Result</p> <ul style="list-style-type: none"> <input checked="" type="checkbox"/> Real-time Track Line <input checked="" type="checkbox"/> Static Track Line <input checked="" type="checkbox"/> View Direction <p>Other</p> <ul style="list-style-type: none"> <input checked="" type="checkbox"/> Track Start  / Stop  Points </div> <div data-bbox="597 1182 1057 1472"> <div style="border: 1px solid #ccc; padding: 10px; margin: 10px 0;"> <p>Start Time</p> <p><input type="text" value="2026-02-24 12:01"/></p> <p>End Time</p> <p><input type="text" value="2026-02-27 02:10"/></p> <p><input type="checkbox"/> End at current time</p> <p style="text-align: right;">✕ ✓</p> </div> </div>
6	Multi-Device Frame	Switches to the multi-device preview. It will only be shown when the device's working mode is Master.
7	Master Device Frame	Switches to the master device preview. It will only be shown when the device's working mode is Master.

NO.	Item	Description
8	Refresh Image	Click it to refresh image. It will only be shown when the device's working mode is Master.
9	Stitched Devices Preview	Shows the positions of all the stitched devices. It will only be shown when the device's working mode is Master.

Configure Rules

This section describes how to configure basic counting functions and AI recognition functions and stitch multiple devices on the **Rule** page.

Configure Basic Counting Functions

To ensure proper device operation, the basic counting functions must be configured first, which include configuring deployment parameters, device strategies, line crossing counting and region monitoring. This section describes how to configure them.

Limitations: Uncontrollable Factors Affecting Accuracy

The following target-related factors may affect people counting accuracy. They are uncontrollable factors, which cannot be predicted or prevented in advance.

- **Target appearance and characteristics:**

- **Low color contrast:** Recognition challenges when targets and the floor have similar colors.
- **Shape similarity:** Non-human objects with a human-like silhouette may trigger false detections.

- **Target motion and density:**

- **High velocity:** Tracking may be inaccurate for individuals walking faster than 2.5 m/s.
- **Dense crowding:** Accuracy decreases when the distance between targets is less than 30 cm.

- **Specific scenarios:**

- **Partial occlusion:** The risk of missed detection increases with the proportion of the target obscured by other objects.
- **Simultaneous bidirectional crossing:** When two people pass through the detection line simultaneously in opposite directions and in close proximity, it may result in a missed count for both individuals.
- **ID inheritance at the FOV edge:** At the FOV edge, the simultaneous disappearance of one target and appearance of another may cause a tracking identity inheritance.

Configure Deployment Parameters

This section describes how to configure deployment parameters.

Steps:

1. In the main page, click **Rule** from the left navigation tree.

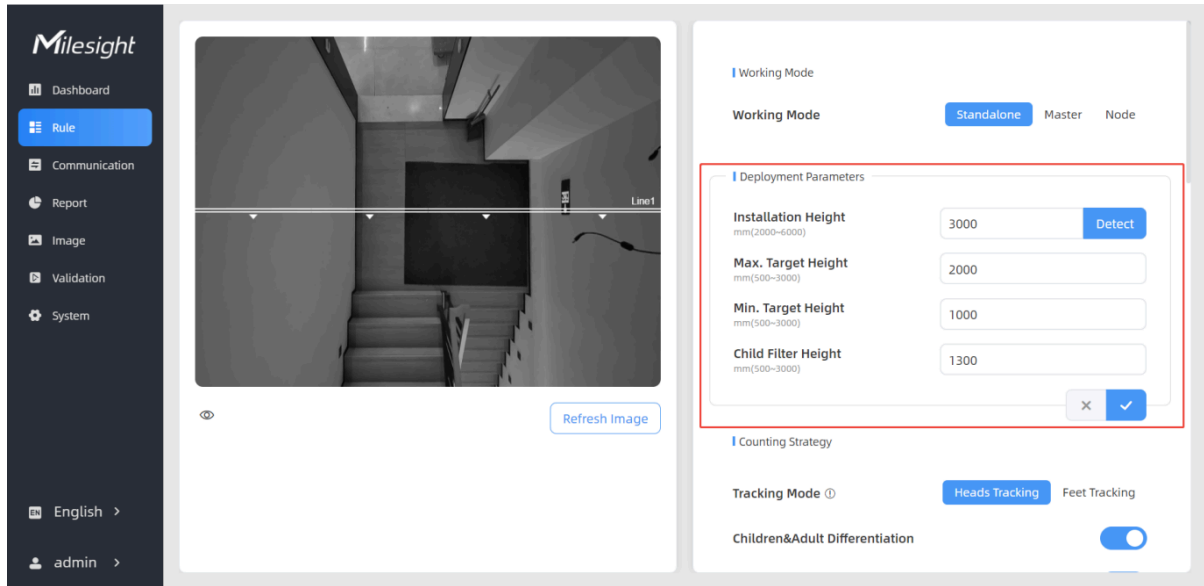

2. In the **Deployment Parameters** area on the right, configure the following parameters as needed.

Parameters	Description
Installation Height	<p>Set the device installation height manually or automatically.</p> <ul style="list-style-type: none"> ◦ To set height manually: Enter a value between 2000 and 6000 mm. <div style="border: 1px solid #ccc; padding: 10px; background-color: #e6f2ff;"> <p> Note: For optimal performance of attribute recognition functions (Gender Recognition, Child & Adult Differentiation, Staff Detection, View Direction Detection), the installation height must not exceed 4 meters.</p> </div>

Parameters	Description
	<ul style="list-style-type: none"> ◦ To set height automatically: click Detect to detect the current installation height. <div data-bbox="630 380 1417 596" style="border: 1px solid #ccc; background-color: #e6f2ff; padding: 10px; margin-top: 10px;"> <p> Note: The accuracy of automatic height detection may be compromised under low-texture ground conditions or in low-light environments such as at night.</p> </div>
Max. Target Height	Set the maximum target height. The device ignores the objects detected above this value. Range: 500-3000 mm.
Min. Target Height	Set the minimum target height. The device ignores the objects detected below this value. Range: 500-3000 mm.
Child Filter Height	This parameter is displayed only when the Children&Adult Differentiation feature is enabled. It sets the maximum child height. Range: 500-3000 mm. For configuration details, refer to Configure Children & Adult Differentiation .

3. Click  to save the configuration.

Configure Device Strategies

This section describes how to configure device strategies, which include **Working Mode**, **Tracking Mode**, **Record Track Start/Stop Points**, **Detection Algorithm Setting** and **Reset Cumulative Count on Schedule**.

Steps:

1. In the main page, click **Rule** from the navigation tree on the left.

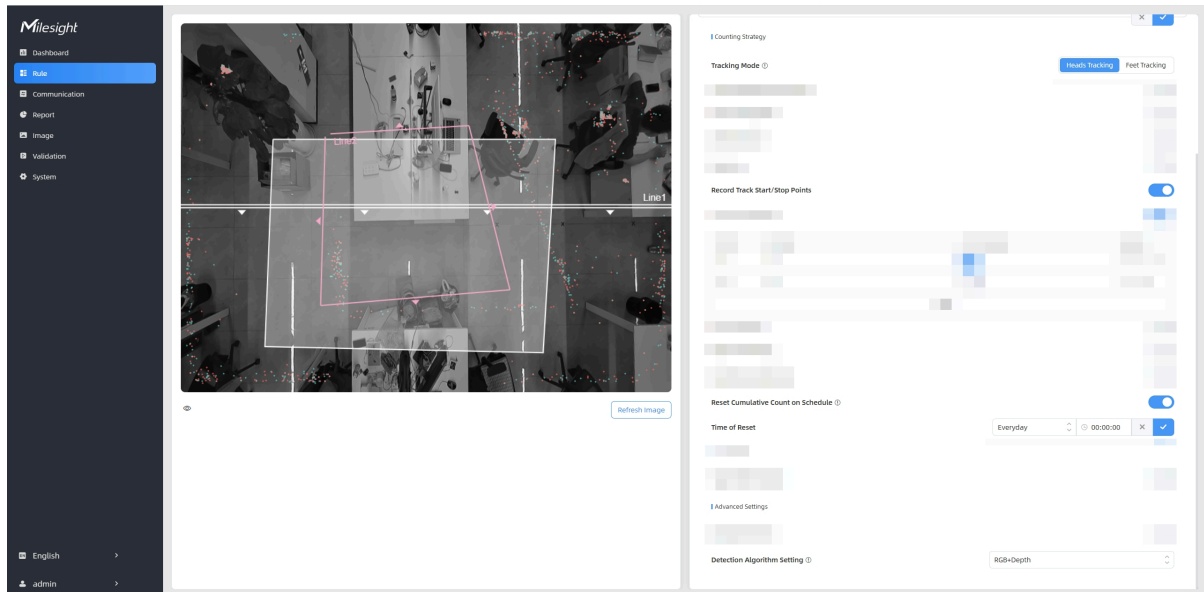

2. Configure the following parameters as needed.

Parameters	Description
<p>Working Mode</p>	<p>Options: Standalone, Master, Node.</p> <ul style="list-style-type: none"> - Standalone: The device operates independently. - Master: The master device handles all functional configuration, counting, and data transmission. This configuration is a must to stitch multiple devices. For details, refer to Stitch Multiple Devices. - Node: Its primary function is to extend the overall detection coverage. This configuration is a must to stitch multiple devices. For details, refer to Stitch Multiple Devices.
<p>Tracking Mode</p>	<p>Sets the tracking mode of counting. Options: Heads Tracking and Feet Tracking.</p> <p>Heads Tracking: When detecting the target's head and shoulders within the FOV, the device generates a trajectory line based on the movement path. This mode applies for most detection scenarios.</p>

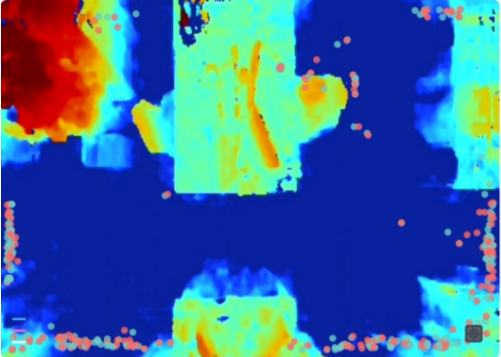
Parameters	Description
	<p>Feet Tracking: When detecting both feet of the target within the FOV, the device generates a trajectory line based on the movement path. It is rarely used in other detection scenarios.</p> <div style="border: 1px solid #ccc; background-color: #e6f2ff; padding: 10px; margin-top: 10px;"> <p> Note: Only Feet Tracking mode is supported in multi-device stitching working mode.</p> </div>
<p>Detection Algorithm Setting</p>	<p>Set the detection algorithm based on the specific application scenarios.</p> <p>RGB+Depth: Suitable for most scenarios.</p> <p>RGB: Enables advanced attribute analysis. This mode can be used to reduce false detections in environments where many inanimate objects are incorrectly identified as people. For example, warehouse entrances/exits where the carried objects may be incorrectly identified as people.</p> <p>Depth: Ideal for privacy-sensitive environments. This mode can be used to enhance detection accuracy in environments with a high density of human-like static objects. It effectively minimizes false identifications in environments like a doll shop, where mannequins and dolls are present.</p>
<p>Record Track Start/Stop Points</p>	<p>Enable this parameter to record the start and end points of person trajectories in the live view for detection line adjustment. The system can store up to 5,000 track points with green indicating the start point and red indicating the end point.</p> 

Parameters	Description
Reset Cumulative Count on Schedule	<p>1. Enable this parameter to periodically reset cumulative counts on a set schedule. Up to 5 reset schedules are supported. Cumulative counts include:</p> <ul style="list-style-type: none"> - Total In/Out counting of each detection line - Max./Avg. Dwell Time of each detection region - Total Effective Audience and Avg. Attention Time of each attention region - Digital Input Trigger Count <p>2. Set Time of Reset and click .</p>

Configure Line Crossing Counting

This section describes how to configure the line crossing counting function.

Add a Detection Line

This section describes how to draw a detection line to count the number of people entering or exiting.

Detection line drawing requirements:

The detection line should satisfy the following requirements to improve detection accuracy:

- Completely traversed by targets.
- Perpendicular to the movement direction.
- Positioned centrally within the detection area.
- Free of adjacent obstructions.
- As close to the center of the preview as possible.
- Maintain sufficient identification space on both sides.

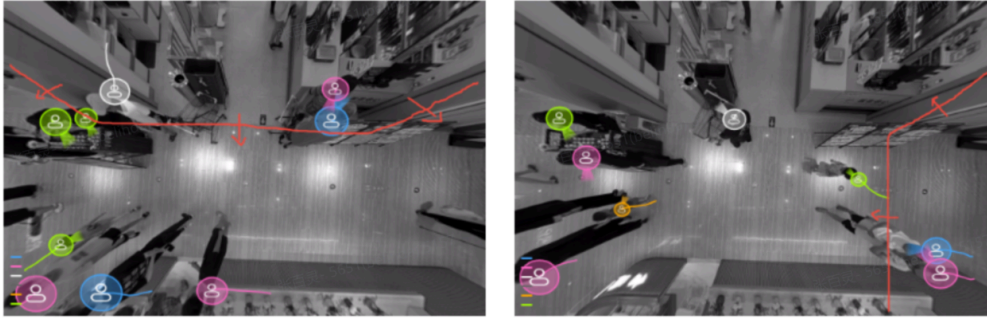

Prerequisite:

The [deployment parameters](#) and [device strategies](#) are configured.

Steps:

1. In the main page, click **Rule** from the navigation tree on the left.
2. In the **Line Cross Counting** area on the right, click **+Add**.

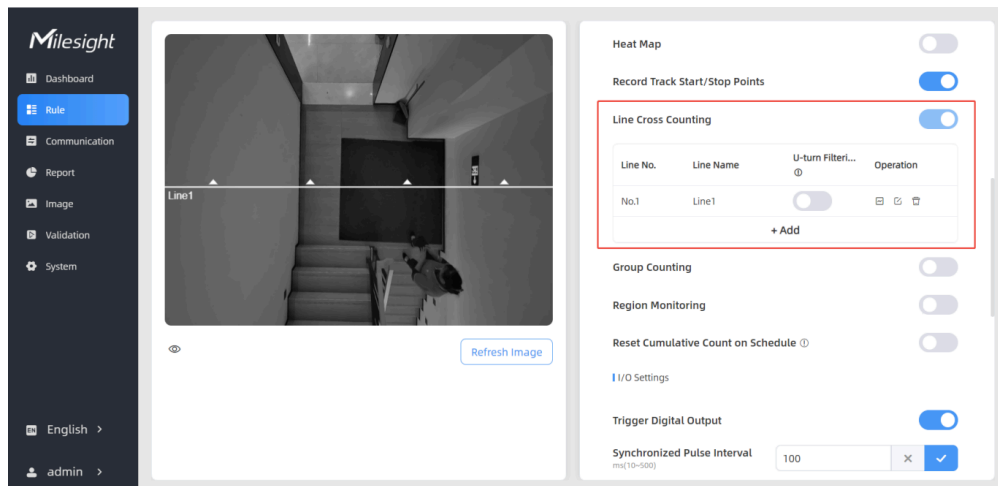



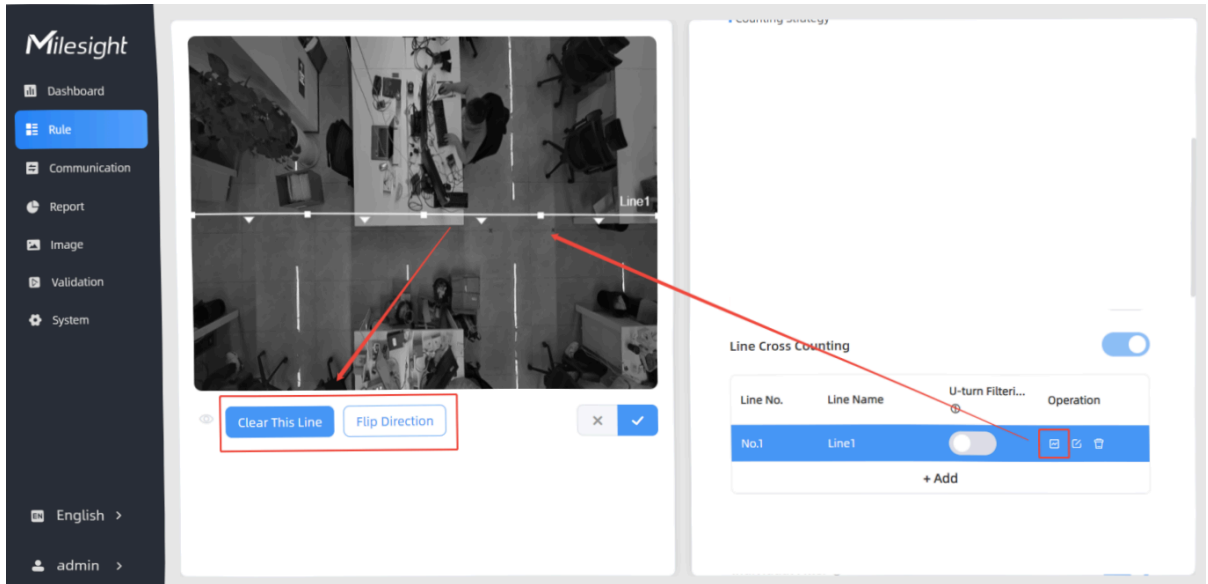



3. Draw a detection line in the preview, you can draw up to 4 polylines with a maximum of 9 line segments per polyline:
 - a. Left-click to start and drag to draw the first line segment. The arrow in the middle of the segment indicates the direction of entry.
 - b. Left-click to add vertices and change direction and drag to draw another line segment.
 - c. Repeat step b to draw more line segments as needed.
 - d. Right-click to finish.
 - e. (Optional) Adjust the line location and length by dragging.
 - f. (Optional) To redraw a line, click **Clear This Line**.
 - g. (Optional) To flip the line direction, click **Flip Direction**.



h. Click  to save the configuration.

4. The line information is listed in the **Line Cross Counting** area.

Line Cross Counting

Line No.	Line Name	U-turn Filtering 	Operation
No.1	Line1	<input type="checkbox"/>	  
No.2	Line2	<input type="checkbox"/>	  
+ Add			

5. (Optional) Click  to customize the line name.

6. (Optional) To enable **U-turn Filtering**, click . For detailed configuration, refer to [Configure U-turn Filtering](#).

7. Check data through any of the following methods:

- To check the visual configuration effect, click **Dashboard** from the left navigation tree.

The screenshot shows the Milesight dashboard interface. On the left is a navigation tree with 'Dashboard' selected. The main content area features three summary cards: 'Line1' with counts for Total In (516), Total Out (513), and Capacity (3); 'Region1' with counts for Total Count (1), Staff Count (0), and Children Count (0); and 'Attention Region1' with counts for Effective Viewers (163), Staff Effective Viewers (38), and Children Effective Viewers (34). To the right is a heatmap visualization of a facility layout with a red arrow pointing to a specific area.

- To view the line data for a certain time period and generate report, click **Report** from the navigation tree on the left. For details, refer to [Generate Reports](#).

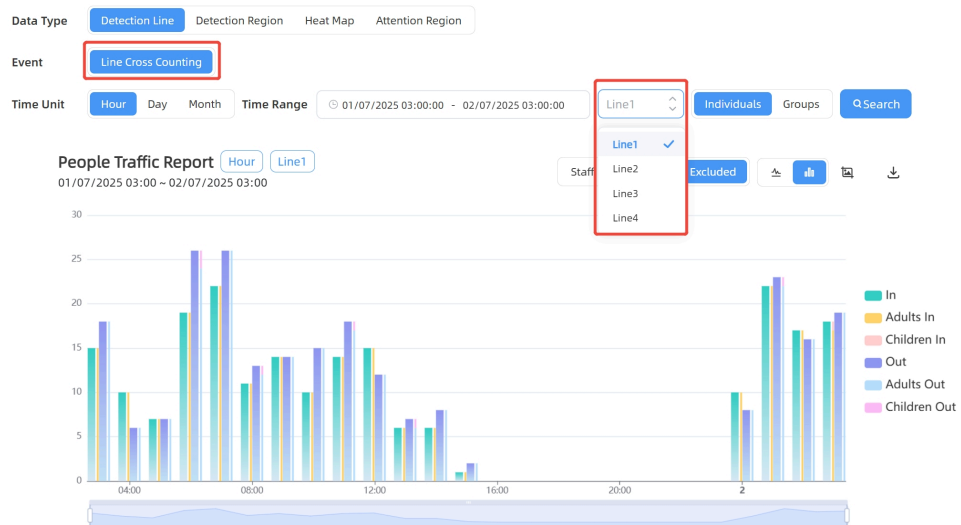

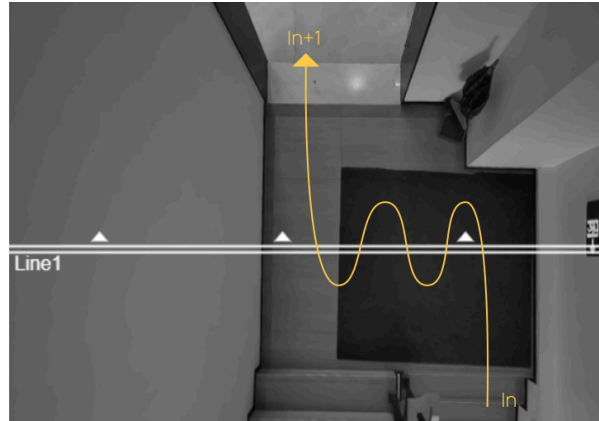

- **Counting example when U-turn filtering is enabled and the U-turn area for the detection line is drawn:**

When you care about the timeliness of the statistics, you can draw the U-turn area.

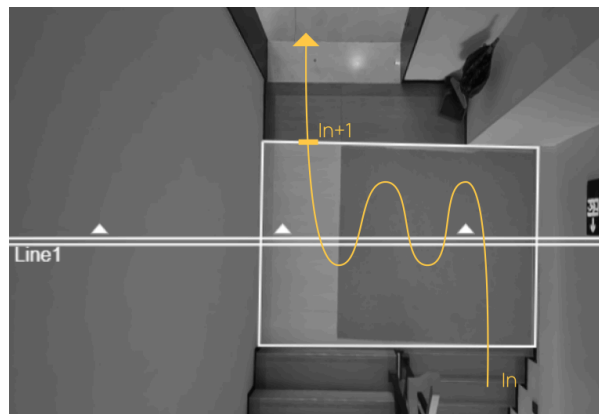



Prerequisite:

A detection line is added in the [Line Cross Counting](#) area on the **Rule** page.

Steps:

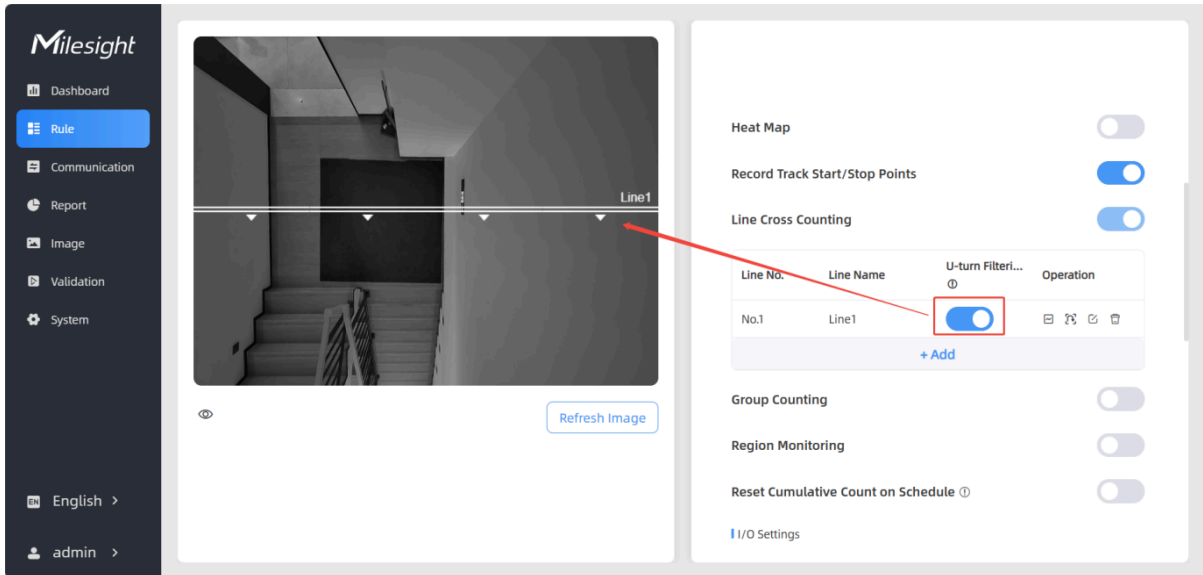
1. In the main page, click **Rule** from the navigation tree on the left.
2. In the **Line Cross Counting** area, enable **U-turn Filtering** to filter repeated counting.



3. Click  to draw a U-turn area for the detection line in the preview.

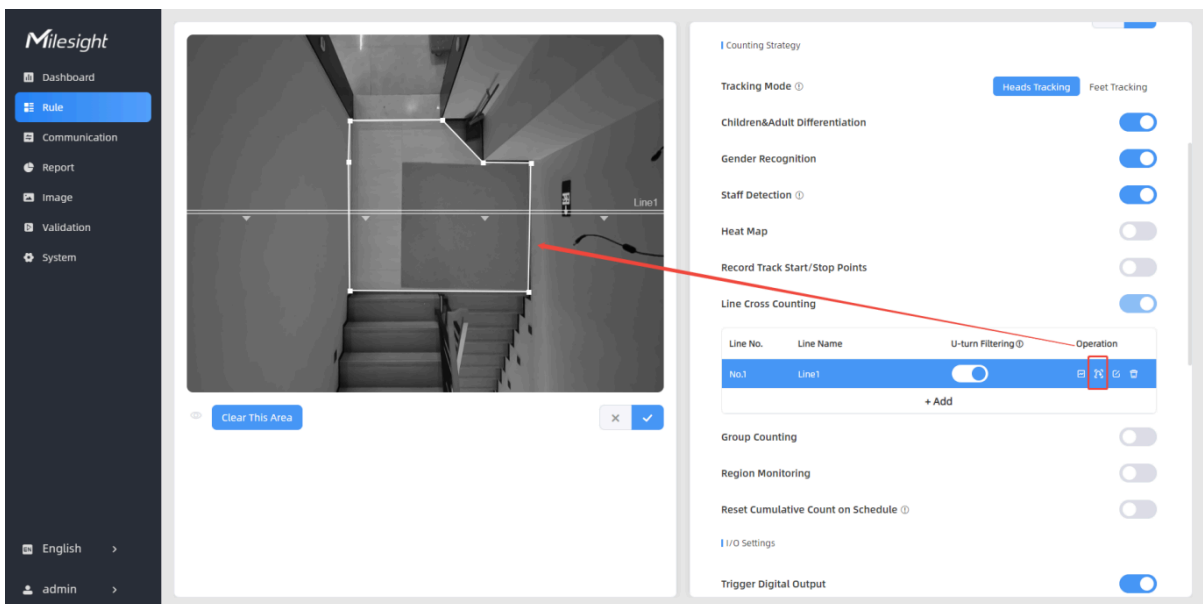

4. (Optional) Draw a U-turn area for the detection line, you can draw up to 4 areas with a maximum of 10 line segments per area:

- Left-click to start and drag to draw the first line segment.
- Left-click to add vertices and change direction and drag to draw another line segment.
- Repeat step b to draw more line segments as needed.
- Right-click to finish.
- (Optional) Adjust the region by dragging.
- (Optional) To redraw an area, click **Clear This Area**.

g. Click  to save the configuration.





Note:

Ensure the movement trajectory is fully included.

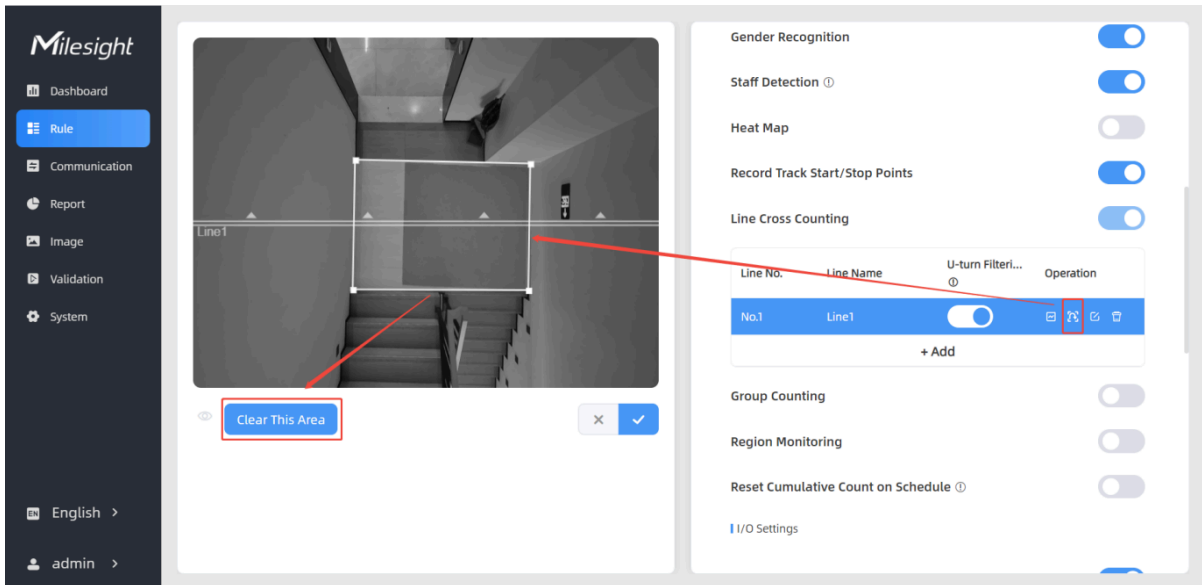
5. (Optional) To delete a U-turn area, click  and click **Clear This Area**.



The screenshot shows the Milesight web configuration interface. On the left is a navigation menu with options: Dashboard, Rule, Communication, Report, Image, Validation, System, English, and admin. The main area is split into two panels. The left panel shows a camera view of a staircase with a white rectangular area labeled 'Line1' and a red line indicating a trajectory. A 'Clear This Area' button is highlighted with a red box. The right panel contains various settings: Gender Recognition (checked), Staff Detection (checked), Heat Map (unchecked), Record Track Start/Stop Points (checked), Line Cross Counting (checked), Group Counting (unchecked), Region Monitoring (unchecked), and Reset Cumulative Count on Schedule (unchecked). Below these settings is a table for Line Cross Counting:

Line No.	Line Name	U-turn Filter...	Operation
No.1	Line1	<input checked="" type="checkbox"/>	  

A red arrow points from the trash icon in the table to the 'Clear This Area' button in the camera view.

6. To check the visual configuration effect, click **Dashboard** from the left navigation tree.

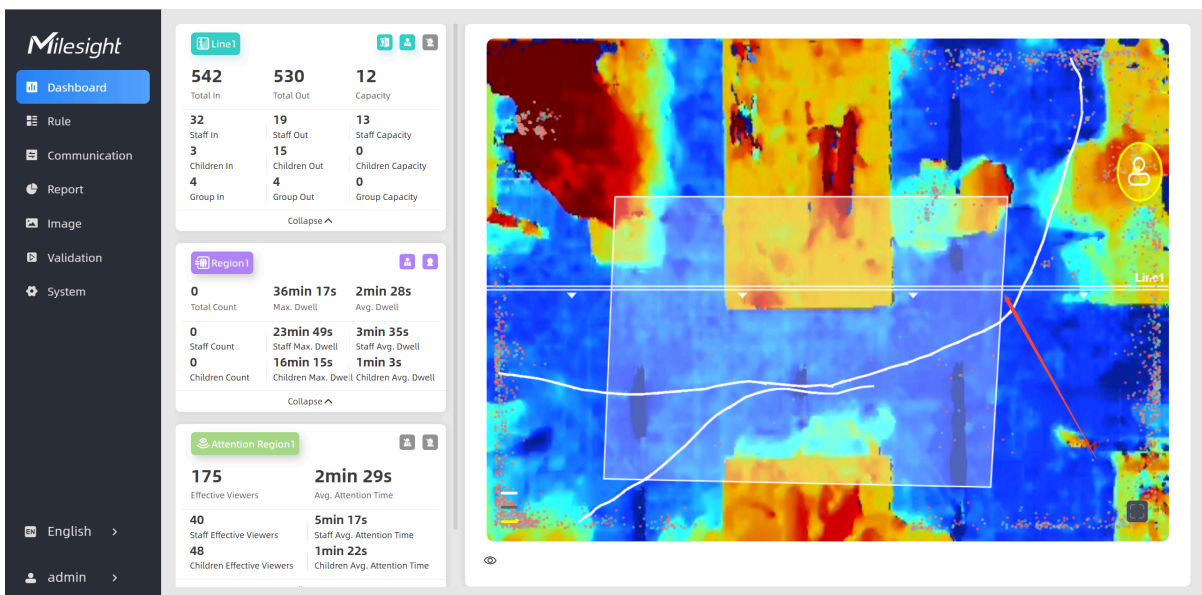

The screenshot shows the Milesight Dashboard. The left navigation menu is the same as in the previous screenshot. The main area is divided into three data cards and a heatmap visualization.

Line1 Data Card:

542	530	12
Total In	Total Out	Capacity
32	19	13
Staff In	Staff Out	Staff Capacity
3	15	0
Children In	Children Out	Children Capacity
4	4	0
Group In	Group Out	Group Capacity

Region1 Data Card:

0	36min 17s	2min 28s
Total Count	Max. Dwell	Avg. Dwell
0	23min 49s	3min 35s
Staff Count	Staff Max. Dwell	Staff Avg. Dwell
0	16min 15s	1min 3s
Children Count	Children Max. Dwell	Children Avg. Dwell

Attention Region1 Data Card:

175	2min 29s
Effective Viewers	Avg. Attention Time
40	5min 17s
Staff Effective Viewers	Staff Avg. Attention Time
48	1min 22s
Children Effective Viewers	Children Avg. Attention Time

The heatmap visualization on the right shows a color-coded area with a white line and a red line, representing the configuration effect.

Configure Region Monitoring

The device supports region monitoring by tracking person count and dwell time within configured regions for generating valuable analytical data. This section describes how to configure region monitoring.

Prerequisite:

The [deployment parameters](#) and [device strategies](#) are configured.

Steps:

1. In the main page, click **Rule** from the left navigation tree.
2. Enable **Region Monitoring** on the right and click **+Add**.

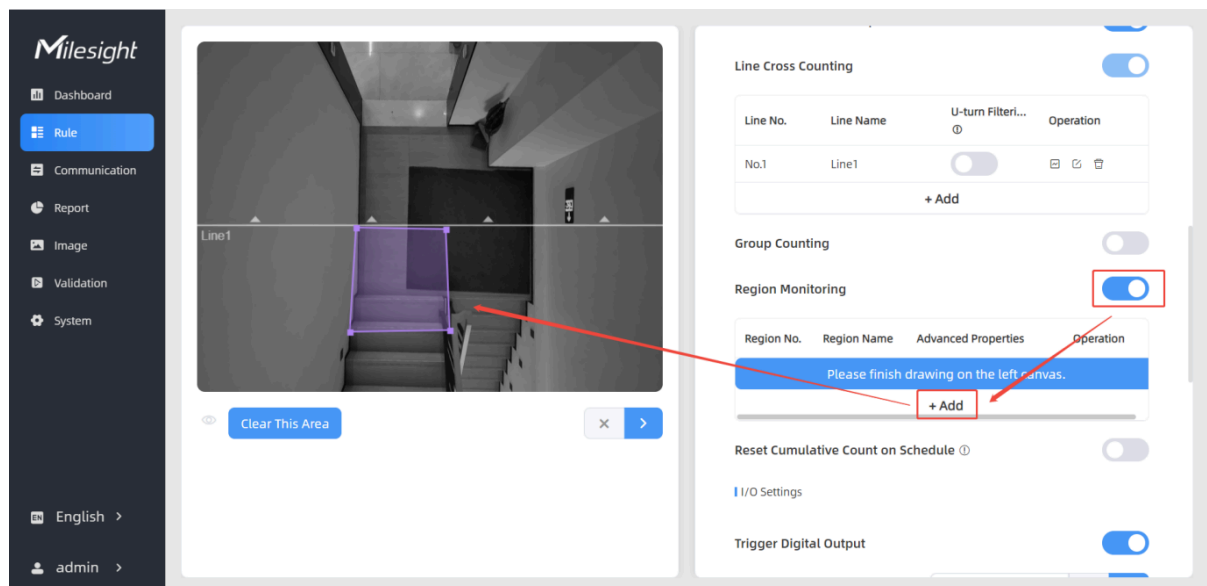

3. Draw a region for monitoring in the live view, you can draw up to 4 regions with a maximum of 9 line segments per region:
 - a. Left-click to start and drag to draw the first line segment.
 - b. Left-click to add vertices and change direction and drag to draw another line segment.
 - c. Repeat step b to draw more line segments as needed.
 - d. Right-click to finish.
 - e. (Optional) Adjust the region by dragging.
 - f. (Optional) To redraw a region, click **Clear This Area**.
4. Click **>**. The **Advanced Properties** dialog box is displayed.

Advanced Properties

Zone Name

Region People Counting

Pass-by Filtering
s(0-3600)

Dwell Time Detection

Min. Dwell Time
s(0-3600)

5. Configure advanced properties parameters.

- a. In the Zone name area, customize the region name.
- b. Enable at least one advanced property. Options: **Region People Counting** and **Dwell Time Detection**.
- c. Perform the following operations as needed.



If	Do
If Region People Counting is enabled	In the Pass-by Filtering text box, enter a value as needed.
If Dwell Time Detection is enabled	In the Min. Dwell Time text box, enter a value as needed.



- d. Click to save the configuration. The region information is displayed in the list on the right.

Region Monitoring

No.	Region Name	Advanced Properties	Operation
No.1	Region1	Region People Counting(5s)	✎ ✏ 🗑
+ Add			

6. (Optional) Perform the following operations as needed.

- To redraw the region, click .
- To modify the advanced properties of the region, click .
- To delete the region, click .

Region Monitoring [Toggle]			
No.	Region Name	Advanced Properties	Operation
No.1	Region1	Region People Counting(5s)	  
+ Add			

7. Check data through any of the following methods:

- To check the visual configuration effect, click **Dashboard** from the left navigation tree.

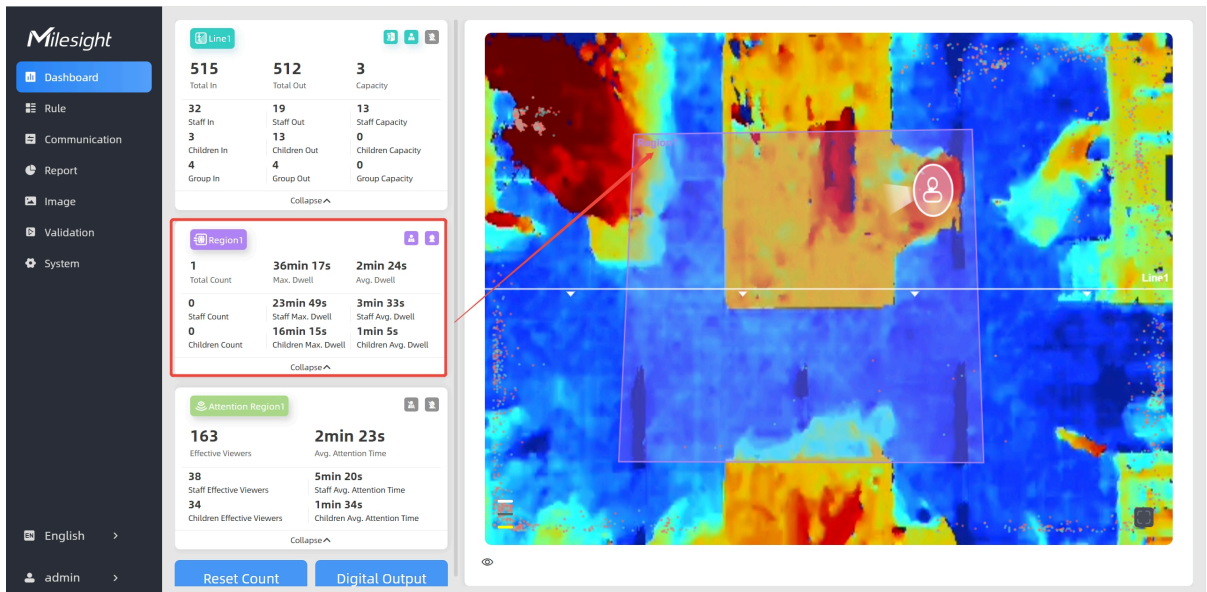

The screenshot displays the Milesight dashboard interface. On the left is a navigation tree with options: Dashboard, Rule, Communication, Report, Image, Validation, and System. The main content area is divided into several data panels:

- Line1 Panel:** Shows counts for Total In (515), Total Out (512), and Capacity (3). It also lists Staff In/Out (32/19), Children In/Out (3/13), and Group In/Out (4/4).
- Region Panel:** Displays a table of region statistics:

Region	Total Count	Max. Dwell	Avg. Dwell
1	36min 17s	2min 24s	
0	23min 49s	3min 33s	
0	16min 15s	1min 5s	
- Attention Region1 Panel:** Shows Effective Viewers (163) and Avg. Attention Time (2min 23s). It also lists Staff Effective Viewers (38) and Children Effective Viewers (34).

On the right side, there is a heatmap visualization of a region. A red box highlights a specific area on the heatmap, and a red arrow points from this box to the Region Panel data table. A person icon is visible on the heatmap, indicating a user's current location or focus.

- To view the region data for a certain time period and generate the corresponding report, click **Report** from the left navigation tree. For details, refer to [Generate Reports](#).

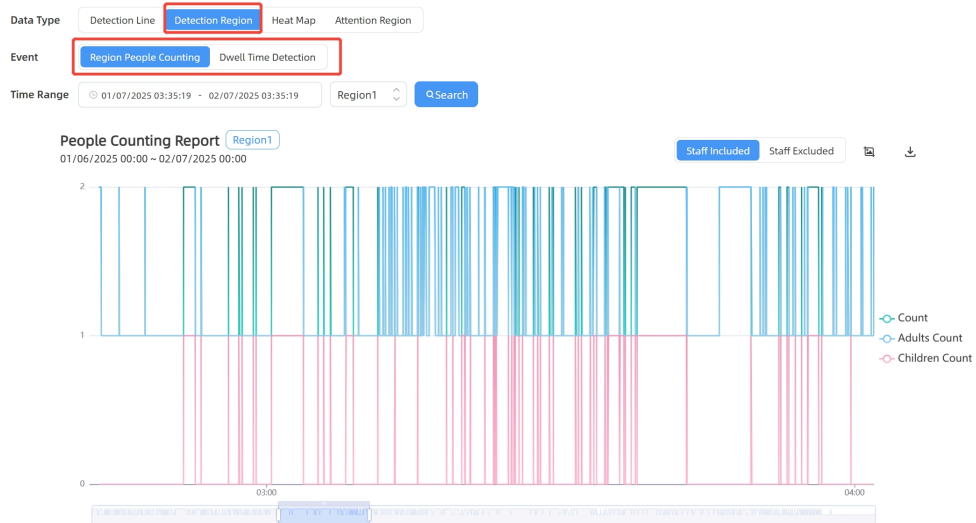

- If recipients are added, check data through command line outputs. For "region_data", refer to [Uplink Data Example for Periodic Reporting](#). For "region_trigger_data", refer to [Uplink Data Examples for Real-Time Reporting](#).

```

"region_data": {
  "dwell_time_data": [{
    "avg_dwell_time": 308367,
    "children_avg_dwell_time": 0,
    "children_max_dwell_time": 0,
    "female_avg_dwell_time": 0,
    "female_max_dwell_time": 519934,
    "male_avg_dwell_time": 0,
    "male_max_dwell_time": 96799,
    "max_dwell_time": 519934,
    "staff_max_dwell_time": 1522,
    "staff_avg_dwell_time": 1522,
    "region": 1,
    "region_name": "Region1",
    "region_uuid": "bd1e6ce2-e113-4ce4-a9b6-0633f7083cac"
  }
],
  "region_count_data": [{
    "total": {
      "current_female": 0,
      "current_male": 1,
      "current_total": 2
    },
    "children": {
      "current_female": 0,
      "current_male": 1,
      "current_total": 2
    },
    "staff": {
      "current_female": 0,
      "current_male": 1,
      "current_total": 2
    },
    "region": 1,
    "region_name": "Region1",
    "region_uuid": "bd1e6ce2-e113-4ce4-a9b6-0633f7083cac"
  }
]
}

```

Configure Obstacle Exclusion

The device supports the **Obstacle Exclusion** function. It can exclude human-like static obstacles from detection when they cannot be avoided through adjustment of detection lines or regions. This section describes how to configure this function.

Steps:

1. In the main page, click **Rule** from the navigation tree on the left.
2. In the **Advanced Settings** area in the bottom on the right, enable **Obstacle Exclusion** and click **Draw**.

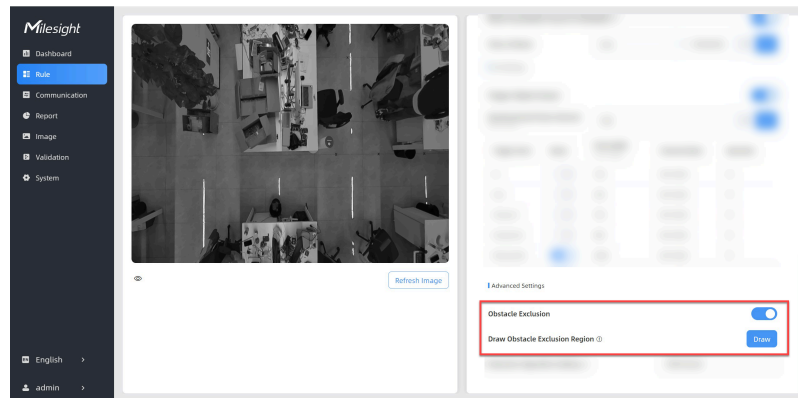

3. Draw an obstacle exclusion area, you can draw up to 4 regions with a maximum of 10 segments per area:

- a. Left-click to start and drag to draw the first line segment.
- b. Left-click to add vertices and change direction and drag to draw another line segment.
- c. Repeat step b to draw more line segments as needed.
- d. Right-click to finish.
- e. (Optional) Adjust the region by dragging.
- f. (Optional) To redraw a region, click **Clear This Area**.
- g. Select the exclusion method:

- **Detection Exclusion:** Select it when you don't want to detect anything in this area. You can just draw the highest part of the obstacle. The device uses this highest part as a reference to automatically exclude this specific area.

For example, in a shelf scenario, you can just frame the upper edge of the shelf, then the shelf won't be mistakenly detected as a person.

- **Height Exclusion:** Select it when you want to avoid false detection caused by mixing obstacles with targets. You can just box out the parts that are easy to confuse with the targets.

For example, in a gate passage scenario, you can outline the gate structure to prevent misclassification. This ensures a child passing through is not identified as an adult, even if the child's silhouette blends with the gate structure.

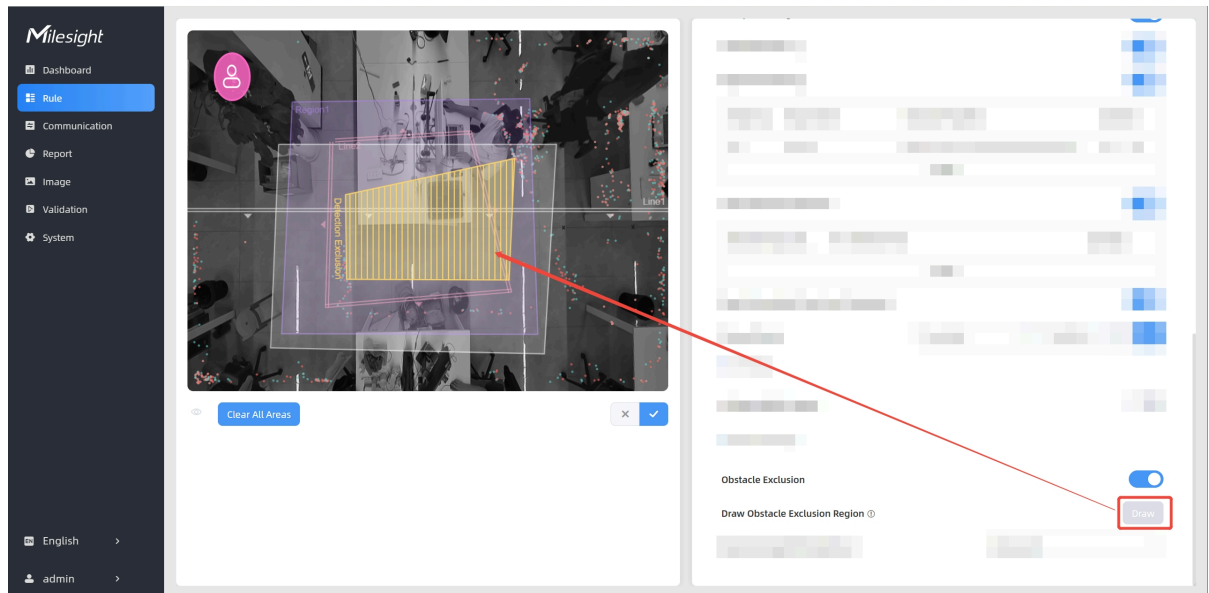

4. Click  to save the configuration.

5. To check the visual configuration effect, click **Dashboard** from the left navigation tree.

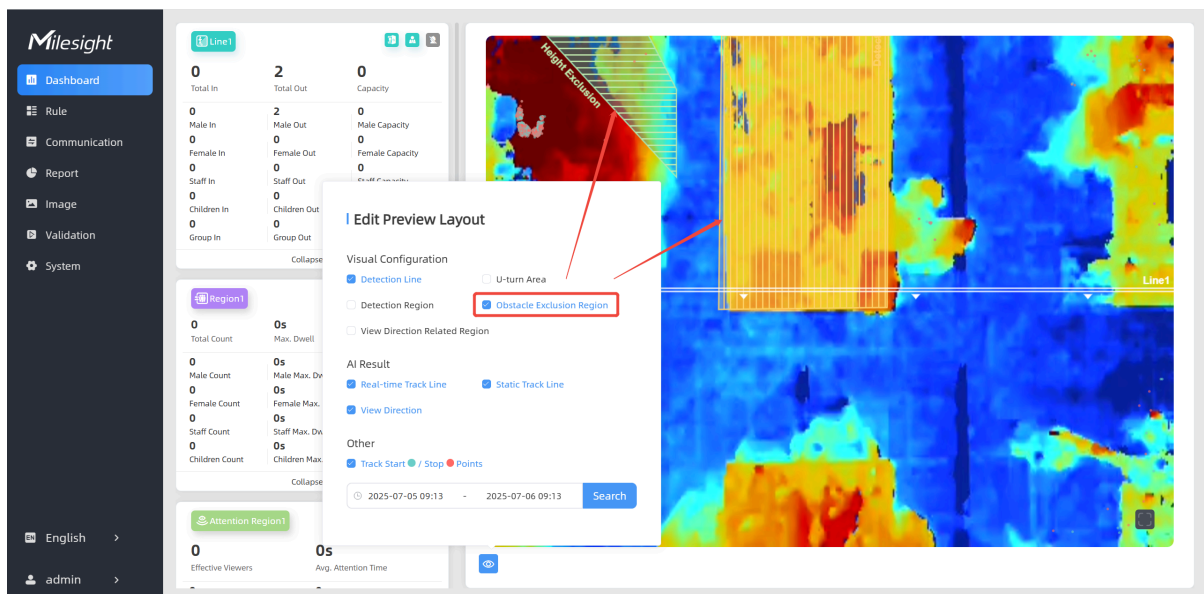

Configure Attribute Recognition Functions

The device uses AI recognition to intelligently distinguish various target attributes. Before using these function, basic counting functions must be configured in advance according to the [Configure Basic Counting Functions](#) section.

Configure Children & Adult Differentiation

The device classifies individuals below the child filter threshold as children. This section describes how to configure the **Children&Adult Differentiation** function.

Limitations: Uncontrollable Factors Affecting Accuracy

The following child-related scenarios may result in undercounting and affect the detection accuracy of this function:

- Children below 1.1 m
- Children in strollers/shopping carts
- Children being held
- Children obstructed from view by adults

Applicable Installation Height: 2.2-4 m

Steps:

1. In the main page, click **Rule** from the left navigation tree.
2. Enable **Children & Adult Differentiation**. The **Child Filter Height** parameter is displayed in the **Deployment Parameters** area.

The screenshot shows the 'Deployment Parameters' section of a web configuration interface. It contains several input fields and a toggle switch:

- Installation Height** (mm(2000-6000)): 2459, with a 'Detect' button.
- Max. Target Height** (mm(500-3000)): 1998.
- Min. Target Height** (mm(500-3000)): 1000.
- Child Filter Height** (mm(500-3000)): 1500. This field is highlighted with a red box, and a red arrow points to it from the 'Children&Adult Differentiation' toggle below.
- Counting Strategy**: A blue checkmark icon is visible.
- Tracking Mode**: Two buttons, 'Heads Tracking' (selected) and 'Feet Tracking'.
- Children&Adult Differentiation**: A toggle switch that is turned on (blue). This entire section is highlighted with a red box.

3. Enter a threshold value in the **Child Filter Height** text box and click  to save the configuration. The device classifies any individual detected below this value as a child.
4. Check data through any of the following methods:
 - To check the visual configuration effect, click **Dashboard** from the left navigation tree.

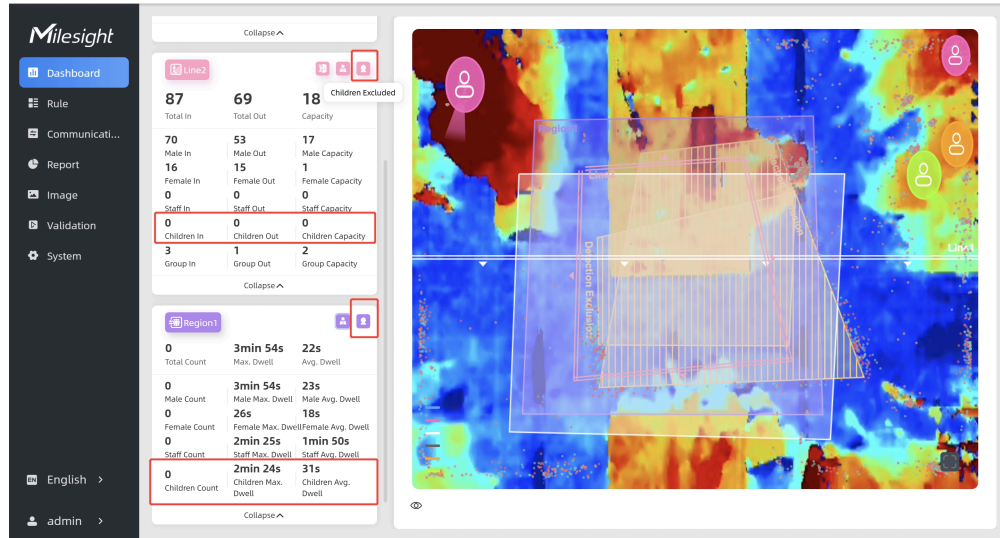

- To view the children data for a certain time period and generate the corresponding report, click **Report** from the left navigation tree. For details, refer to [Generate Reports](#).



- If recipients are added, check data through command line outputs. For details, refer to [Uplink Data Example for Periodic Reporting](#) and [Uplink Data Examples for Real-Time Reporting](#).

Configure Gender Recognition

The device supports gender recognition, allowing it to determine whether a person is male or female based on physical appearance and clothing style. This section describes how to configure the **Gender Recognition** function.

Limitations: Uncontrollable Factors Affecting Accuracy

- Targets have hairstyles that contrast with typical gender presentations (e.g., long hair on males or short hair on females).
- Targets' hair or clothing color is close to the floor color.
- Targets wear large concealing accessories (e.g., head scarves).
- Passing speed exceeding 2.5 m/s may cause missed detection.

Applicable Installation Height: 2.2-4 m

Steps:

1. In the main page, click **Rule** from the navigation tree on the left.

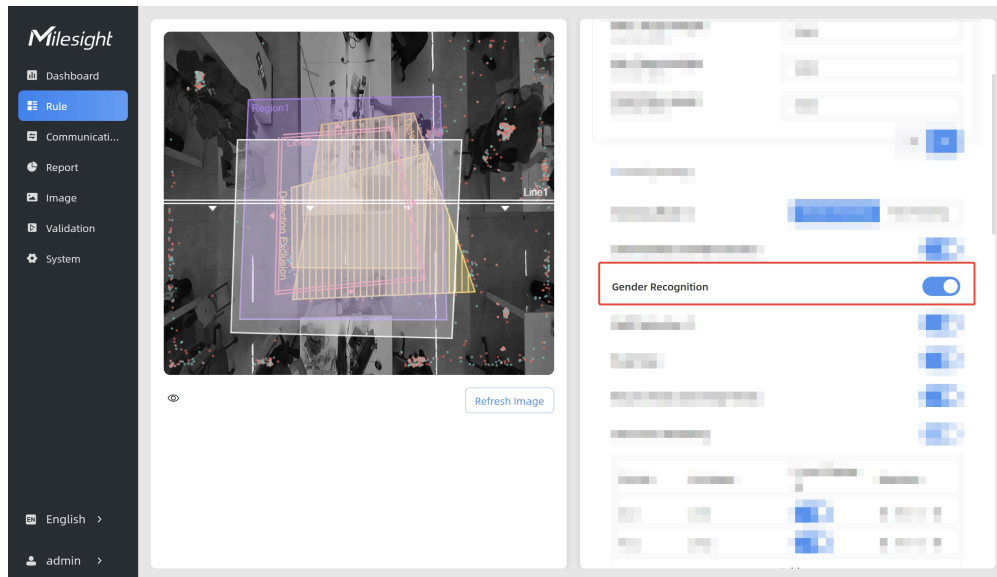

2. Enable **Gender Recognition**.
3. Check data through any of the following methods:

- To check the visual configuration effect, click **Dashboard** from the left navigation tree.

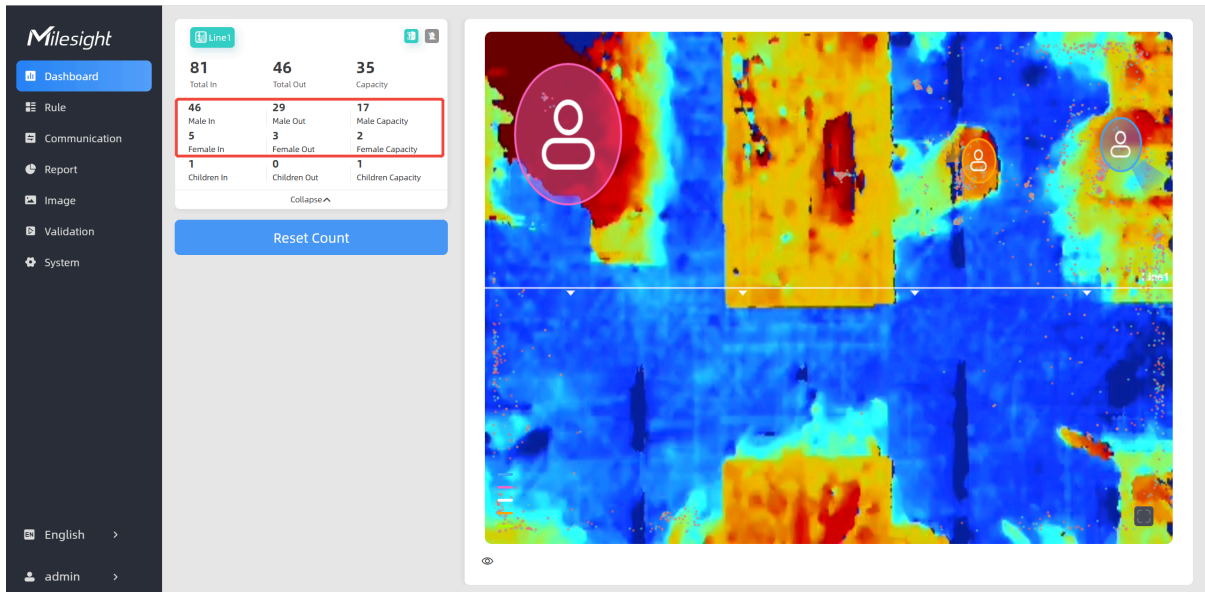

- To view the gender-specific data for a certain time period and generate the corresponding report, click **Report** from the left navigation tree . For details, refer to [Generate Reports](#).

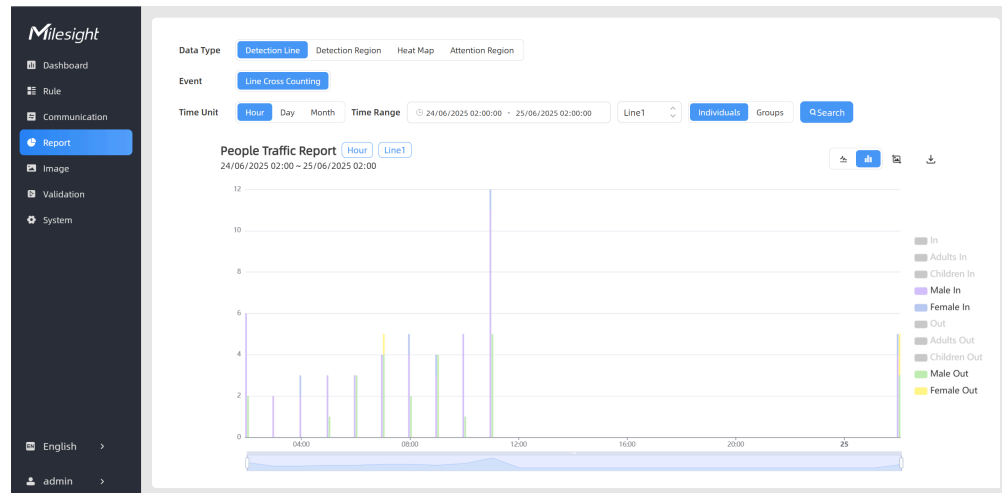

- If recipients are added, check data through command line outputs. For details, refer to [Uplink Data Example for Periodic Reporting](#) and [Uplink Data Examples for Real-Time Reporting](#).

Configure Staff Detection

The device supports staff detection by identifying personnel wearing designated accessories. This section describes how to configure the **Staff Detection** function.

Limitations: Uncontrollable Factors Affecting Accuracy

- When two individuals walk side by side, the device may incorrectly classify the person without a staff accessory as staff, while failing to recognize the actual staff member wearing the accessory.
- Clothing with patterns resembling staff lanyards (such as striped designs) may cause false staff detection.
- Passing speed exceeding 2.5 m/s may cause missed detection.

Staff Accessories Requirements:

For detailed requirements regarding staff accessories, refer to the following table.

Item	Requirement
Accessory selection	<p>It is recommended to use the staff accessories provided by Milesight.</p> <p>Staff accessories are available in black and red. Red accessories are recommended for optimal detection against dark-colored staff uniforms.</p>
Usage specifications	<p>Staff accessories (lanyards, badges, and epaulettes) must be tested independently and must not be used concurrently.</p> <p>Multiple accessory types are prohibited in the same scene simultaneously.</p>
Wearing requirements	<p>When worn, accessories must remain fully visible and unobstructed by collars, scarves, hair, or any other objects.</p> <p>Staffs must wear these accessories in designated locations.</p> <ul style="list-style-type: none"> • Staff lanyard: Wear it around the neck. • Staff badge: Wear it on one side of the upper chest area. • Staff epaulet: Wear it on each shoulder.

Applicable Installation Height: 2.2-4 m



Note:

For badge detection at heights exceeding 3.5 m, detection accuracy decreases significantly due to reduced image clarity.

Steps:

1. In the main page, click **Rule** from the navigation tree on the left.
2. Enable **Staff Detection** and select the corresponding accessory.

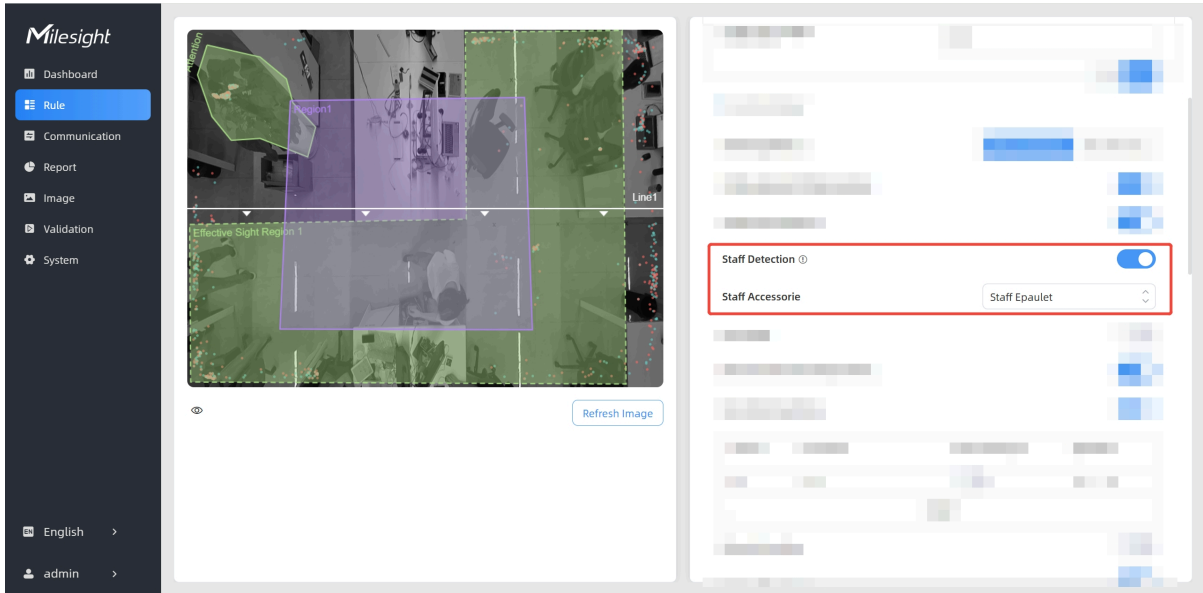

3. From the **Staff Accessories** drop-down list, select an accessory for staff detection.
4. Check data through any of the following methods:
 - To check the visual configuration effect, click **Dashboard** from the left navigation tree.

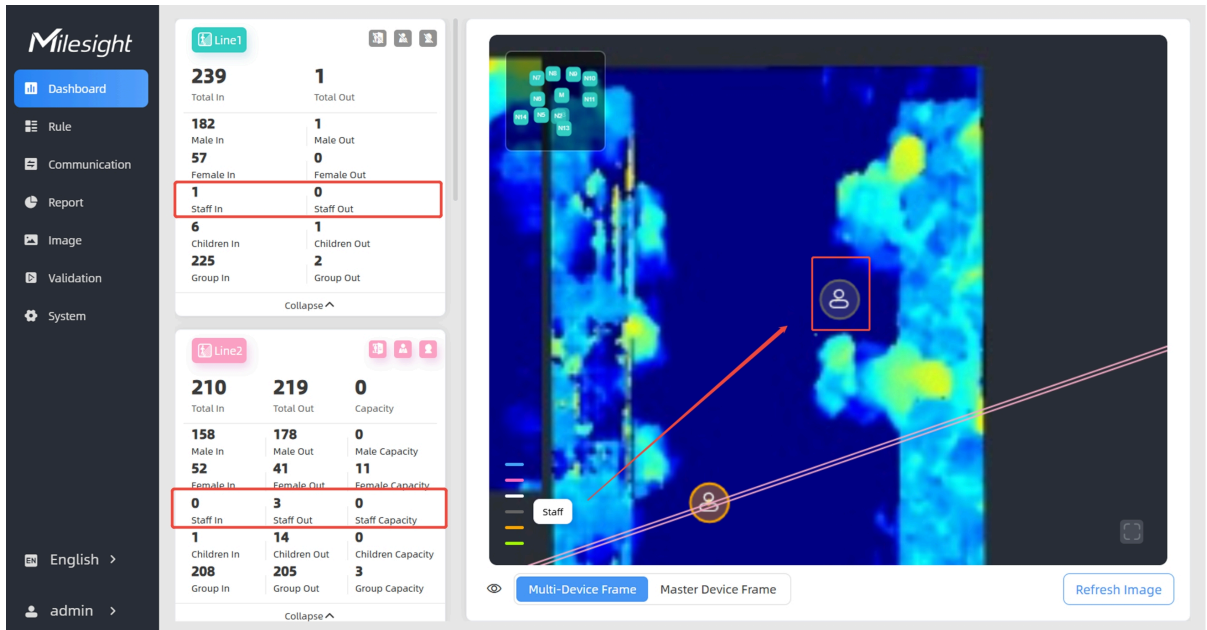

- To view the staff data for a certain time period and generate the corresponding report, click **Report** from the left navigation tree. For details, refer to [Generate Reports](#).

Data Type

Event

Time Unit Time Range

People Traffic Report

22/06/2025 08:00 ~ 23/06/2025 08:00

- If recipients are added, check data through command line outputs. For details, refer to [Uplink Data Example for Periodic Reporting](#) and [Uplink Data Examples for Real-Time Reporting](#).

Configure Group Counting

The device supports multi-person recognition and counting within the detection area. By analyzing variations in human spacing, movement directions, and speed differences, it provides advanced customer behavior analysis. Group Counting is built upon the Line Crossing Detection functionality. This section describes how to configure the **Group Counting** function.

Applicable Installation Height: 2.2-6 m

Steps:

1. In the main page, click **Rule** from the left navigation tree.

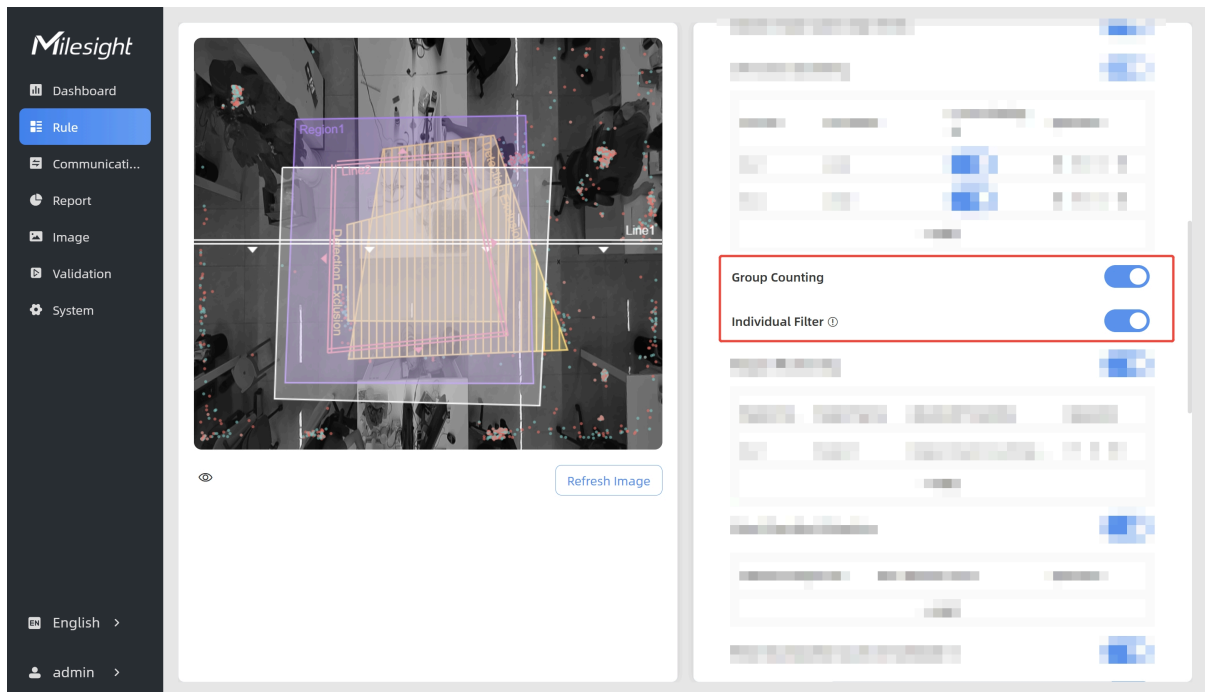

2. Enable the **Group Counting** function. The device classifies any individual and any party of two or more individuals as a group.
3. (Optional) To only classify two or more individuals as a group, enable **Individual Filter**. When it is enabled, individuals will not be counted as a group.
4. Check data through any of the following methods:
 - To check the visual configuration effect, click **Dashboard** from the left navigation tree.

Line2		
171 Total In	136 Total Out	35 Capacity
138 Male In	110 Male Out	28 Male Capacity
32 Female In	25 Female Out	7 Female Capacity
0 Staff In	0 Staff Out	0 Staff Capacity
0 Children In	0 Children Out	0 Children Capacity
10 Group In	2 Group Out	8 Group Capacity

Collapse ^

- To view the group data for a certain time period and generate the corresponding report, click **Report** from the left navigation tree. For details, refer to [Generate Reports](#).

Data Type Detection Line Detection Region Heat Map Attention Region

Event Line Cross Counting

Time Unit Hour Day Month Time Range Line1

- If recipients are added, check data through command line outputs. For details, refer to [Uplink Data Example for Periodic Reporting](#) and [Uplink Data Examples for Real-Time Reporting](#).

Configure View Direction Detection

The device supports the **View Direction Detection** function. It tracks targets' view tracks to effectively evaluate advertisement reach-through. This section describes how to configure this function.

Applicable Installation Height:

Applicable Installation Height: 2.2-4 m

Prerequisites:

- The tracking mode is set to **Heads Tracking**.
- The working mode is set to **Standalone**.

Steps:

1. In the main page, click **Rule** from the navigation tree on the left.
2. Enable **View Direction Detection** on the right and click **+Add**. The **How-to Settings** information box is displayed.

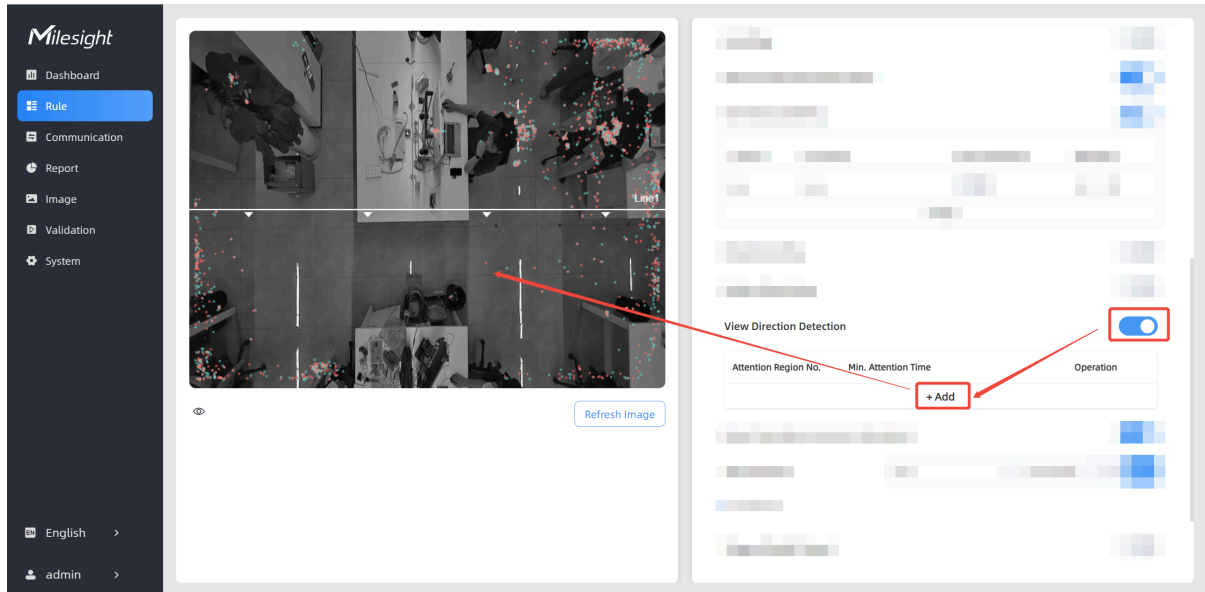

3. Browse the steps and click .

| How-to Settings

Step 1

Please draw the Attention Region based on advertisement or shelf shape.



Step 2

Please draw the Effective Sight Region without being blocked by obstacles.



Step 3

Please configure the Min. Attention Time for people to focus on the Attention Region.



Do not remind me again



4. Draw an attention region that requires analysis of customer engagement levels, you can draw up to 6 regions with a maximum of 10 line segments per region:

- a. Left-click to start and drag to draw the first line segment.
- b. Left-click to add vertices and change direction and drag to draw another line segment.
- c. Repeat step b to draw more line segments as needed.
- d. Right-click to finish.
- e. (Optional) Adjust the region by dragging.

f. (Optional) To redraw a region, click **Clear This Area**.

g. Click .

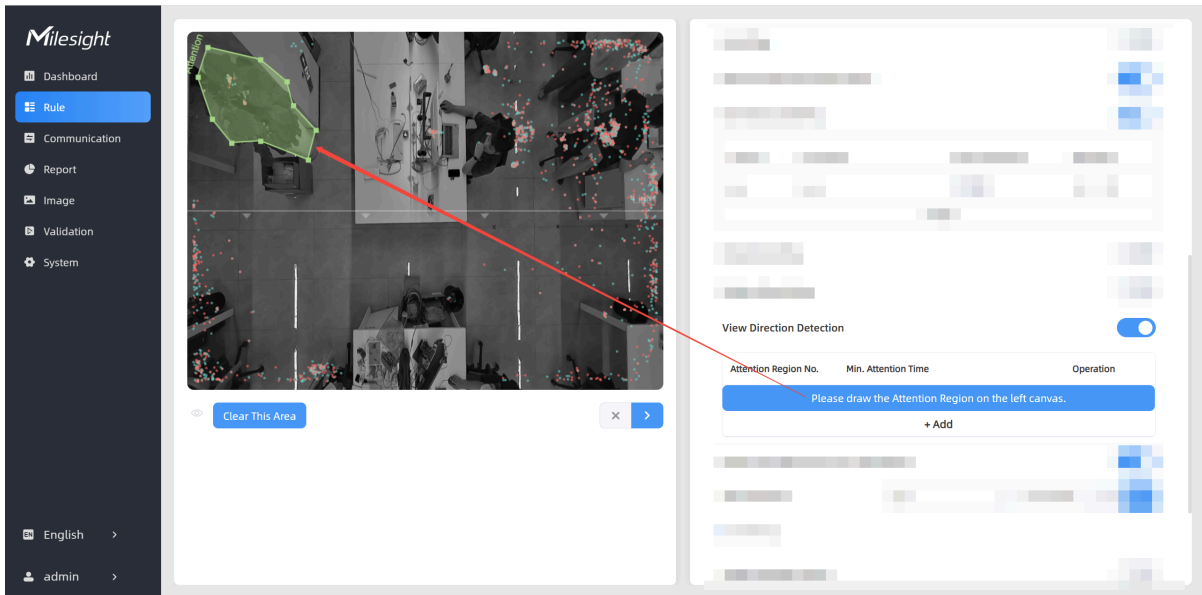

5. Following the same steps in Step 4 to draw an effective sight region, you can draw up to 6 regions with a maximum of 10 line segments per region:

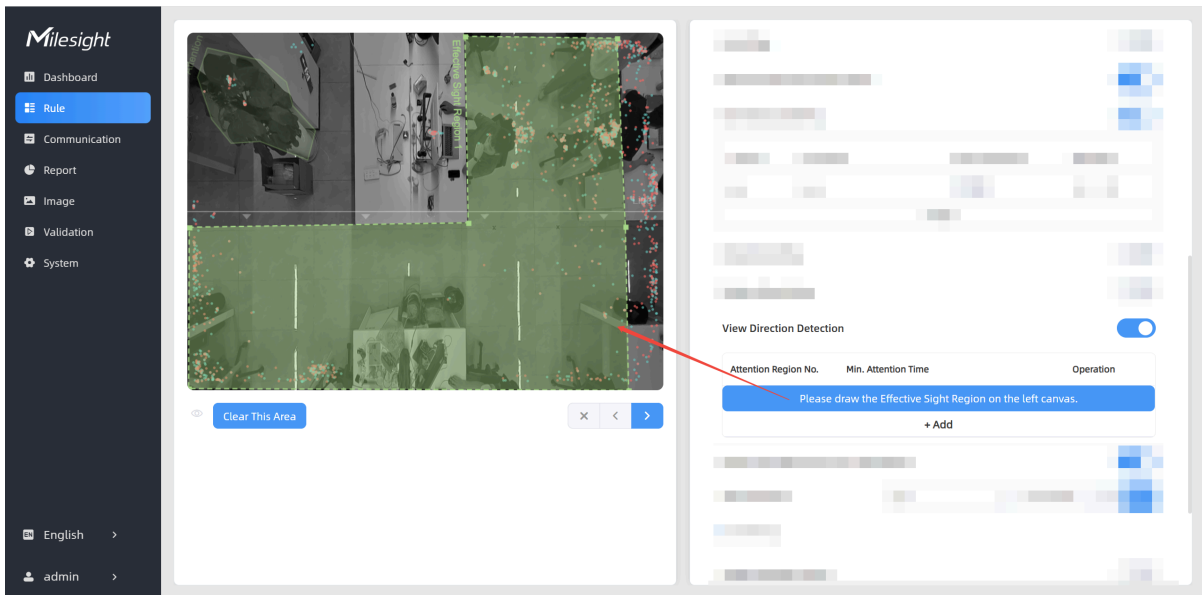

Any individual within this region must have an unobstructed view of the attention region.

Once configured, the device analyzes gaze direction within the effective sight region based on the following logic:

- Effective Viewer: Target who accumulates attention time > Min. Attention Time
- Accumulation Starts: When gaze overlaps with attention region for >1 second
- Accumulation Pauses: When gaze moves outside attention region

6. Click . The **Advanced Properties** dialog box is displayed.

Advanced Properties

Min. Attention Time
s(1~60)

7. Set **Min. Attention Time** and click  to save the configuration. Then the device identifies any target as an effective viewer if his gaze remains on the attention region for a duration longer than this specified value.

8. To validate configuration:

- Stand in the effective sight region and look toward the attention region.
- Observe the real-time tracking on Dashboard.
- Verify gaze direction is accurately represented.
- Check that attention time accumulates when gazing at the target.

9. Check data through any of the following methods:

- To check the visual configuration effect, click **Dashboard** from the left navigation tree.

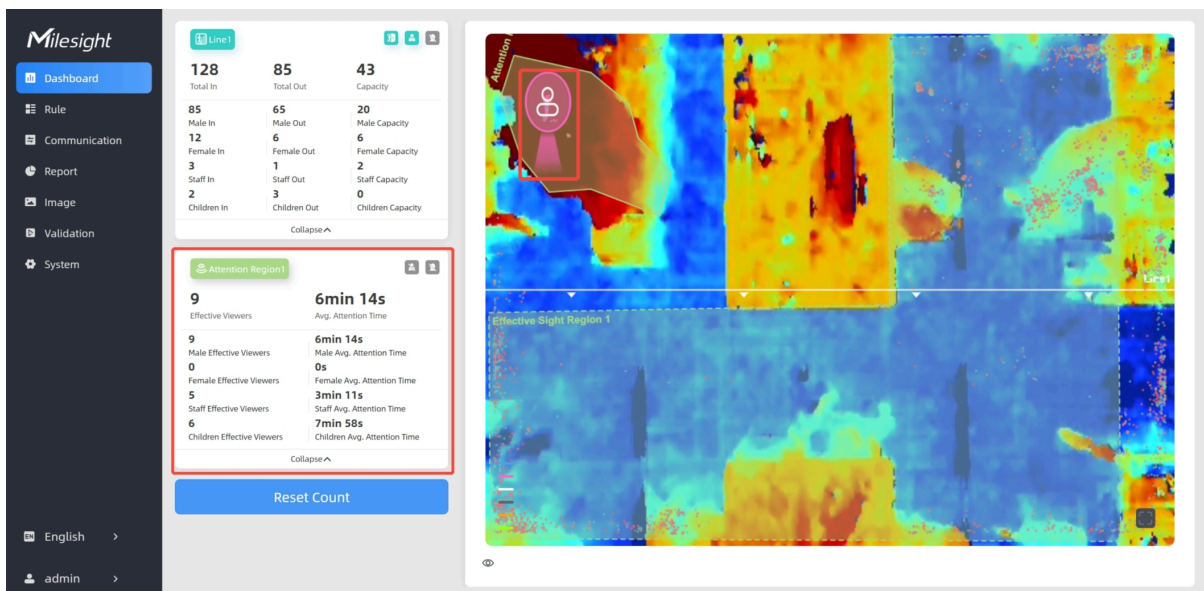

The screenshot displays the Milesight dashboard interface. On the left is a navigation menu with options: Dashboard, Rule, Communication, Report, Image, Validation, and System. The main content area is divided into several sections:

- Line 1 Summary:**

128 Total In	85 Total Out	43 Capacity
85 Male In	65 Male Out	20 Male Capacity
12 Female In	6 Female Out	6 Female Capacity
3 Staff In	1 Staff Out	2 Staff Capacity
2 Children In	3 Children Out	0 Children Capacity
- Attention Region 1:**

9 Effective Viewers	6min 14s Avg. Attention Time
9 Male Effective Viewers	6min 14s Male Avg. Attention Time
0 Female Effective Viewers	0s Female Avg. Attention Time
5 Staff Effective Viewers	3min 11s Staff Avg. Attention Time
6 Children Effective Viewers	7min 58s Children Avg. Attention Time
- Visual Configuration:** A heatmap on the right shows the 'Effective Sight Region 1' with a red 'Attention' area overlaid. A person icon indicates the current gaze direction.

A 'Reset Count' button is located at the bottom of the Attention Region 1 section.

- To view attention region data for a certain time period and generate the corresponding report, click **Report** from the left navigation tree. For details, refer to [Generate Reports](#).

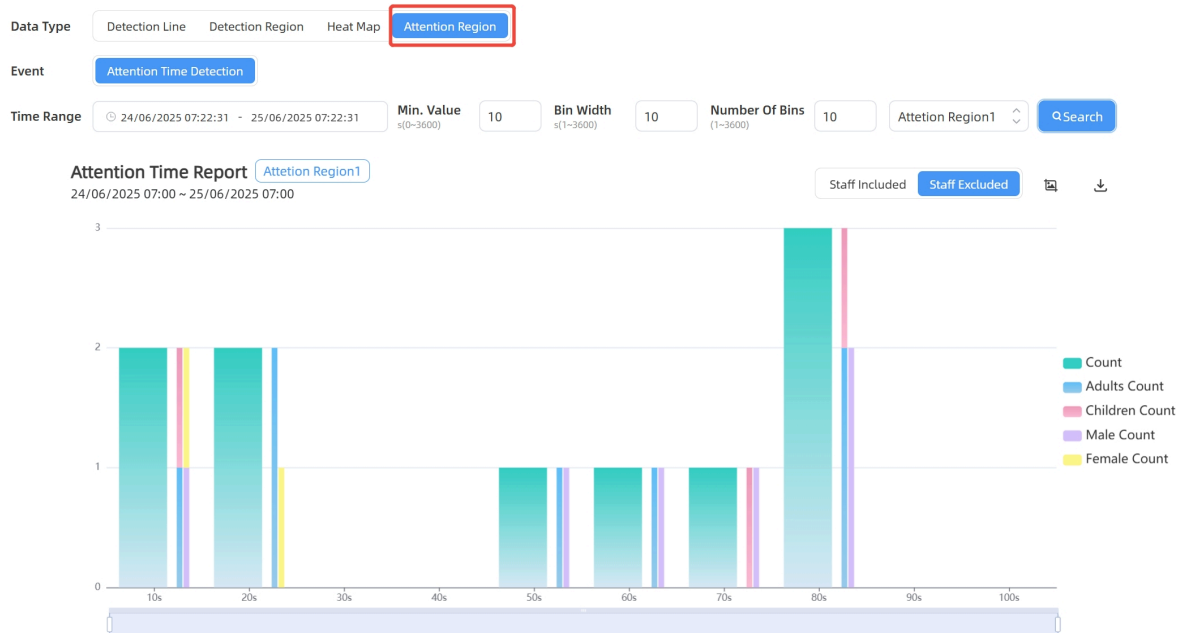

- If recipients are added, check data through command line outputs. For "attention_region_total_data", refer to [Uplink Data Example for Periodic Reporting](#). For "attention_region_trigger_data", refer to [Uplink Data Examples for Real-Time Reporting](#).

Configure Digital Output Triggering

If the **Trigger Digital Output** function is enabled, the device can send pulse signals when the target passes through the detection line. This section describes how to configure this function.

Prerequisite:

The device is connected to the corresponding external device using the multi-interface cable according to the [wiring diagram](#).

Steps:

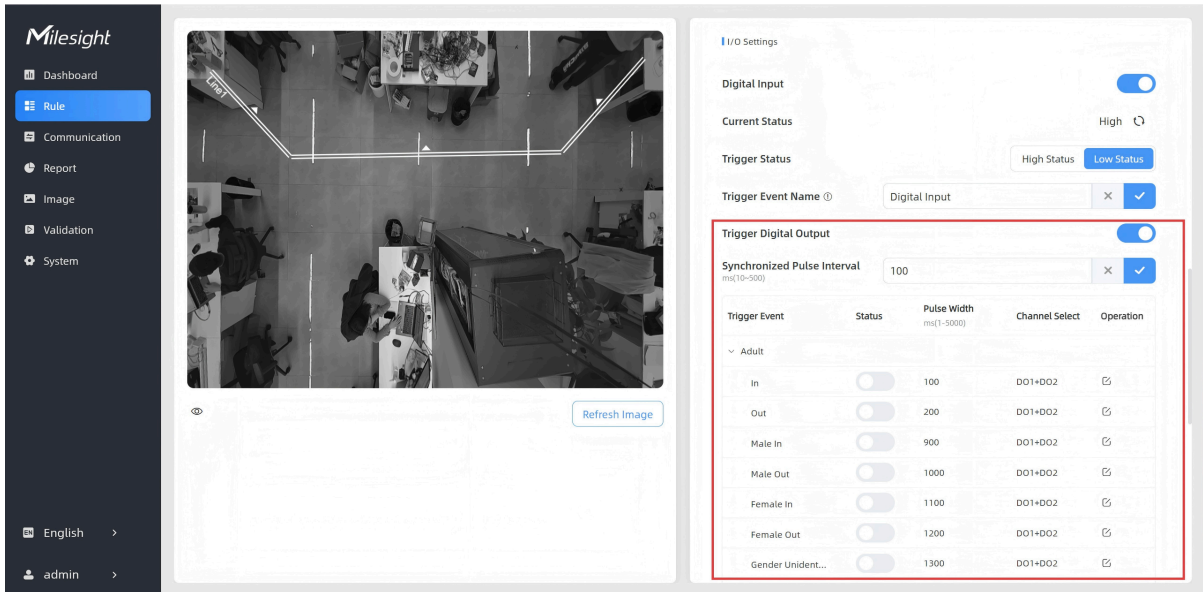

1. In the main page, click **Rule** from the navigation tree on the left.
2. In the **I/O Settings** area on the right, enable **Trigger Digital Output**.



3. Enter a value in the **Synchronized Pulse Interval** text box and click .

Parameters	Description
Synchronized Pulse Interval	The interval between multiple pulses when several people pass through or multiple events trigger simultaneously.

4. Enable a specific trigger event. For a description of each parameter, refer to the following table.

- a. Click .
- b. Click  for the events.
- c. Set **Pulse Width**.
- d. Select a channel from the **Channel Select** drop-down list.
- e. Click . The device output high-level signals through the multi-interface automatically.

Trigger Event	Status	Pulse Width ms(1-5000)	Channel Select	Operation
∨ Adult				
In	<input type="checkbox"/>	100	DO1+DO2	
Out	<input type="checkbox"/>	200	DO1+DO2	
Male In	<input type="checkbox"/>	900	DO1+DO2	
Male Out	<input type="checkbox"/>	1000	DO1+DO2	
Female In	<input type="checkbox"/>	1100	DO1+DO2	
Female Out	<input type="checkbox"/>	1200	DO1+DO2	
Gender Unident...	<input type="checkbox"/>	1300	DO1+DO2	
Gender Unident...	<input type="checkbox"/>	1400	DO1+DO2	
> Children				
∨ Staff				
In	<input type="checkbox"/>	500	DO1+DO2	
Out	<input type="checkbox"/>	600	DO1+DO2	
Manual DO	<input checked="" type="checkbox"/>	5000	DO1+DO2	

Parameters	Description
Trigger Event	Events to trigger the DOs to send pulse signals. Note: When staff events trigger pulse signals, the device does not initiate synchronized outputs for gender or adult detection events.
Status	Enable or disable the event to trigger pulse signal output.
Pulse Width	Pulse signal duration.

Parameters	Description
Channel Select	Select which DO port to output the pulse signal.
Operation	Click  to edit the above-mentioned parameters.

Configure Digital Input

If the **Digital Input** function is enabled, the device can collect high-level and low-level signals from external devices (such as buttons, sensors, etc.) via the DI port. These external physical signals are converted into digital signals, enabling the device to monitor external events.





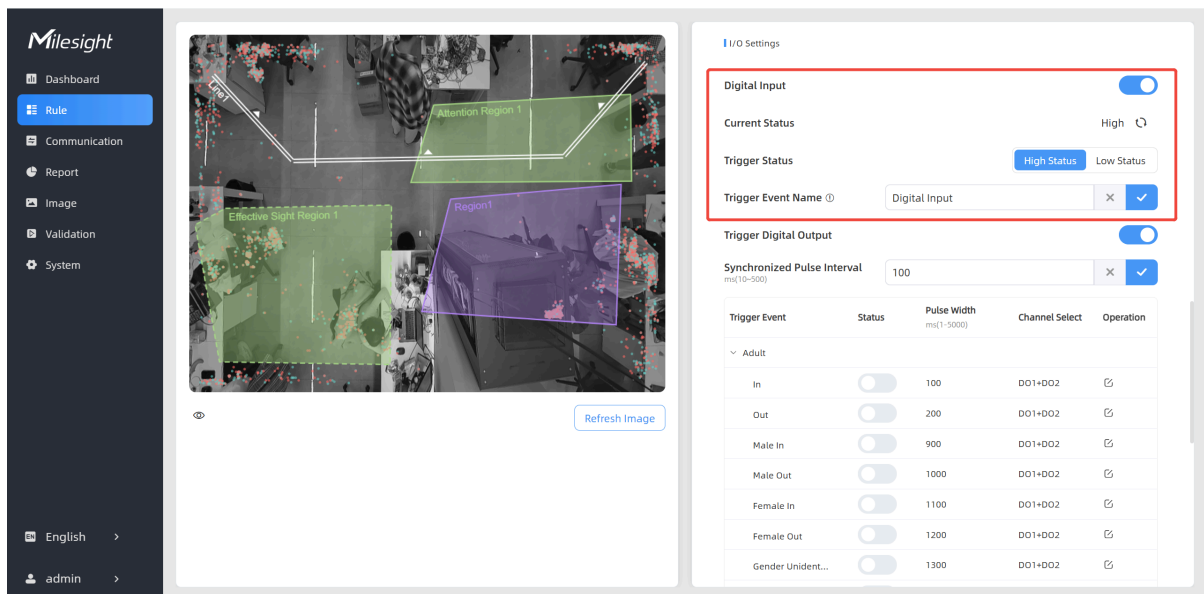

Prerequisite:

The device is connected to the external device using the multi-interface cable according to the [wiring diagram](#).

Steps:

1. In the main page, click **Rule** from the navigation tree on the left.
2. In the **I/O Settings** area on the right, enable **Digital Input**.



Trigger Event	Status	Pulse Width ms(1-5000)	Channel Select	Operation
Adult				
In	<input type="checkbox"/>	100	DO1+DO2	
Out	<input type="checkbox"/>	200	DO1+DO2	
Male In	<input type="checkbox"/>	900	DO1+DO2	
Male Out	<input type="checkbox"/>	1000	DO1+DO2	
Female In	<input type="checkbox"/>	1100	DO1+DO2	
Female Out	<input type="checkbox"/>	1200	DO1+DO2	
Gender Unident...	<input type="checkbox"/>	1300	DO1+DO2	

3. Configure the following parameters as needed.

Parameters	Description
Current Status	Display the status of the DI interface.

Parameters	Description
Trigger Status	<p>Optional: High Status, Low Status.</p> <p>Only when the trigger status is the same as the current status, will the device count the data.</p> <p>By default, two connected contacts = low level, two disconnected contacts = high level.</p>
Trigger Event Name	Customize the trigger event name.

4. Check data through any of the following methods:

- To check the DI configuration effect, click **Dashboard** from the left navigation tree.

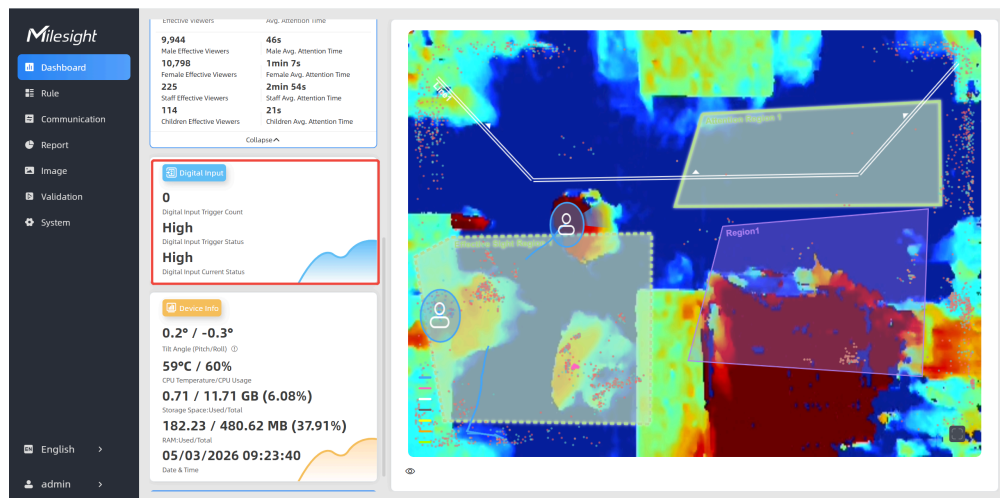

- To view the DI data for a certain time period and generate the corresponding report, click **Report** from the left navigation tree. For details, refer to [Generate Reports](#).
- If recipients are added, check data through command line outputs. For details, refer to [Uplink Data Example for Periodic Reporting](#) and [Uplink Data Examples for Real-Time Reporting](#).

Example:

The VS361 acts as an external device connected to the DI interface of the VS125. When the VS361 detects someone crossing the line, it sends a signal to the VS125, which subsequently counts the event.

Configure Heat Map

The **Heat Map** function analyzes personnel movement and dwell time data and displays the analytical results through color-coded temporal or spatial visualizations. This provides insights for better business management. This section describes how to configure this function.

The device supports **Motion Heatmap** and **Dwell Heatmap**. **Motion Heatmap** visualizes areas with the highest pedestrian traffic density, while **Dwell Heatmap** visualizes the areas with the maximum occupant dwell duration.

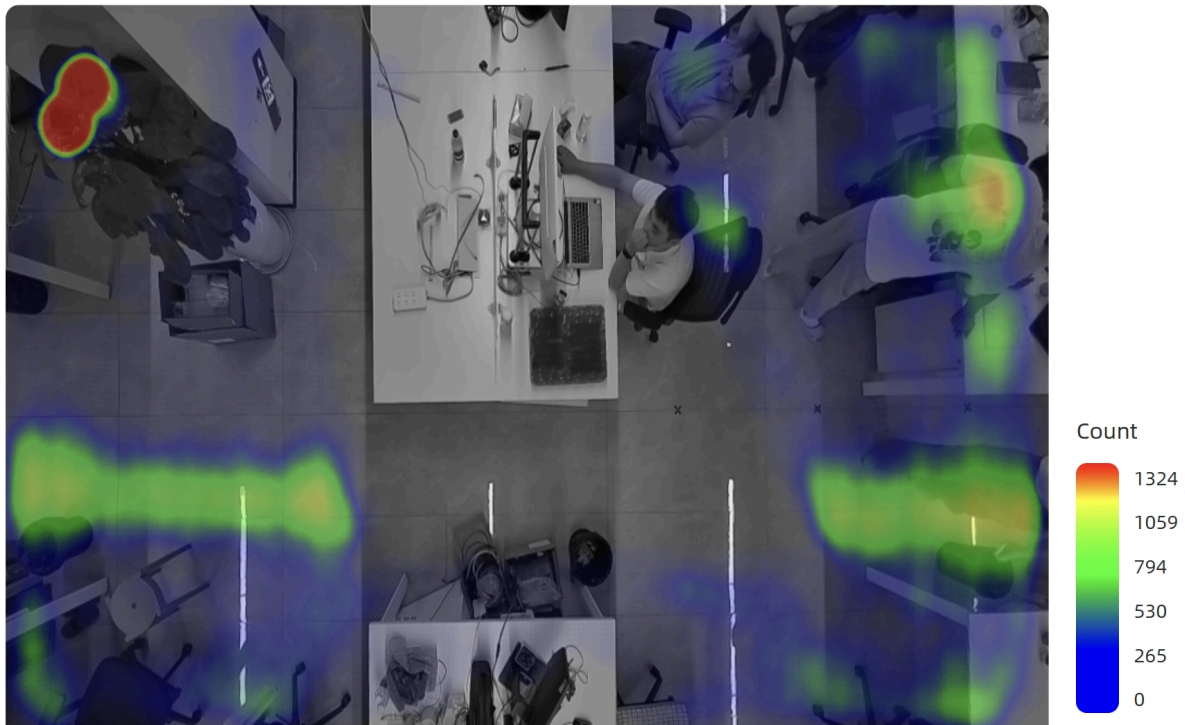

Steps:

1. Enable the **Heat Map** function.
2. View the heat map data for a certain time period and generate the corresponding report, click **Report** from the left navigation tree. For details, refer to [Generate Reports](#).

Data Type	<input type="button" value="Detection Line"/> <input type="button" value="Detection Region"/> <input checked="" type="button" value="Heat Map"/> <input type="button" value="Attention Region"/>
Event	<input checked="" type="button" value="Motion Heatmap"/> <input type="button" value="Dwell Heatmap"/>
Time Range	<input type="button" value="🕒 22/06/2025 09:00:00 - 23/06/2025 09:00:00"/> <input type="button" value="🔍 Search"/>

Stitch Multiple Devices

The device supports multi-device stitching, which extends the monitoring coverage beyond the capability of a single device. A maximum of 16 devices can be stitched. This section describes how to stitch multiple devices.

Device Roles in a Stitched System:

- Master device: One device is set to **Master**. It handles all functional configuration, counting, and data transmission.
- Node device: All other devices are set to **Node**. Their primary function is to extend the overall detection coverage.

Preparations:

- Installation: Multiple devices are installed according to [Install the device](#).
- Network: All devices must be on the same subnet.
- Firmware: All devices must be updated to the latest version.

Configuration Procedure:

After completing the preparations, designate one device as the master device and the remaining devices as node devices, follow the sequence below sections.

Configure a Node Device

This section describes how to configure node devices.

Steps:

1. Log into the web GUI of the node device, and click **Communication** from the left navigation tree.
2. In the **IP Address** text box in the **TCP/IP** area, enter the IP address of the node device.

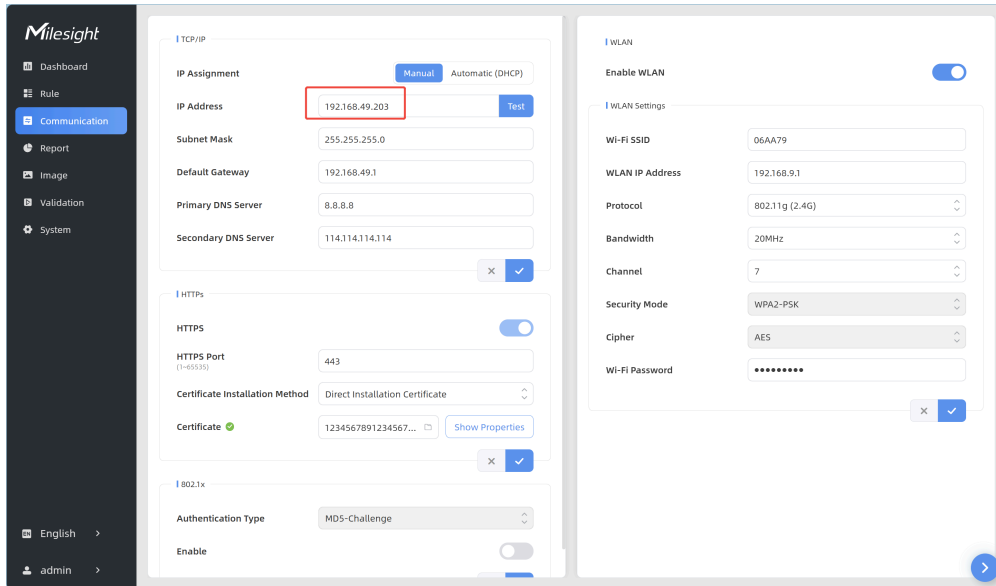

3. Click **Rule** from the left navigation tree.

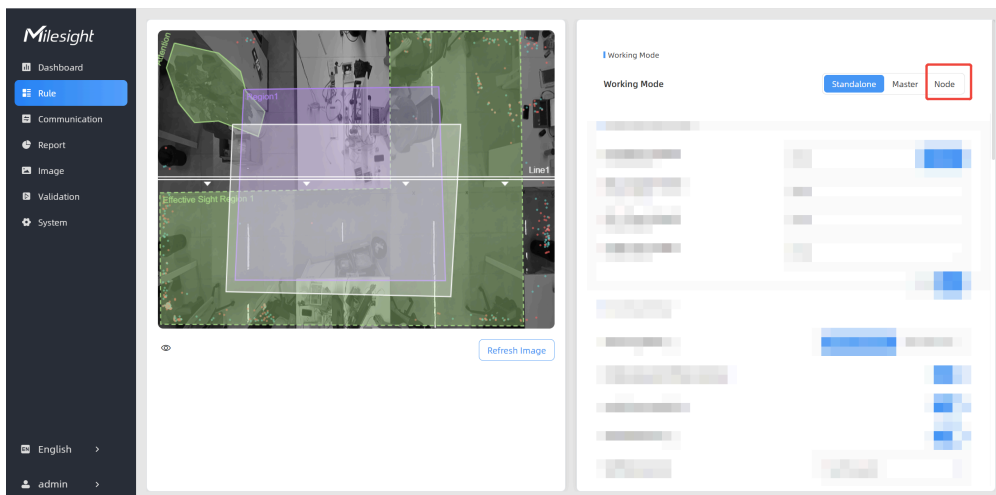

4. In the **Working Mode** area on the right, click **Node**. The **Tips** information box is displayed.

Tips

The device needs to reboot to switch to the new Working Mode.
Continue?



5. Click  to wait for the device to reboot.

The following page is displayed after successful stitching. For parameter description in the **Master Device Info.** area, refer to the following table.

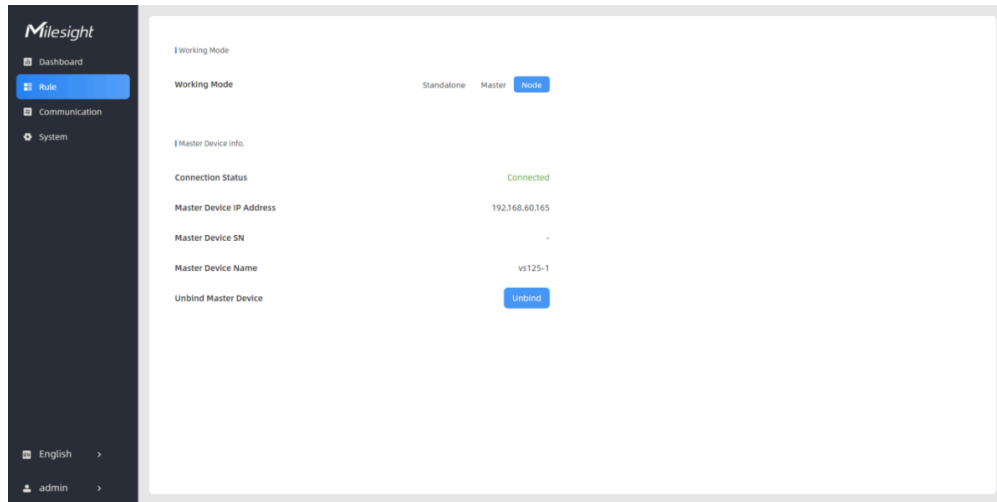

Parameters	Description
Connection Status	Connection status between the node device and master device.
Master Device IP Address	Master device IP address. If this IP address is within the same subnet as the node device, the node device can be bound to the master device.
Master Device SN	Master device serial number.
Master Device Name	Master device name.
Unbind Master Device	Click Unbind to release the connection. This device will be deleted from the list of the master device.

Stitch the Master Device and Node Devices

This section describes how to stitch the master device and node devices, which includes the following procedures:

1. Set **Working Mode** to **Master**.
2. Select a node device.
3. Bind the node device to the master device.

After all stitching configurations are completed, users can draw detection lines and even U-turn areas on the stitched preview using the same method as with standalone devices. **Multi-Device Frame** and **Master**

Device Frame are displayed on the **Dashboard** page to view the stitched multi-device preview and the master device preview respectively.

Set Working Mode to Master

1. Log into the web GUI of the master device, and click **Rule** from the left navigation tree.
2. In the **Working Mode** area on the right, click **Master**. The **Tips** information box is displayed.
3. Click  to wait for the device to reboot.

Tips

The device needs to reboot to switch to the new Working Mode.
Continue?



Select a Node Device

1. After the reboot is completed, click **Rule** from the left navigation tree.
2. In the **Multi-Device List** area, click **Bind Node1**. The **Select a Node Device** dialog box is displayed.

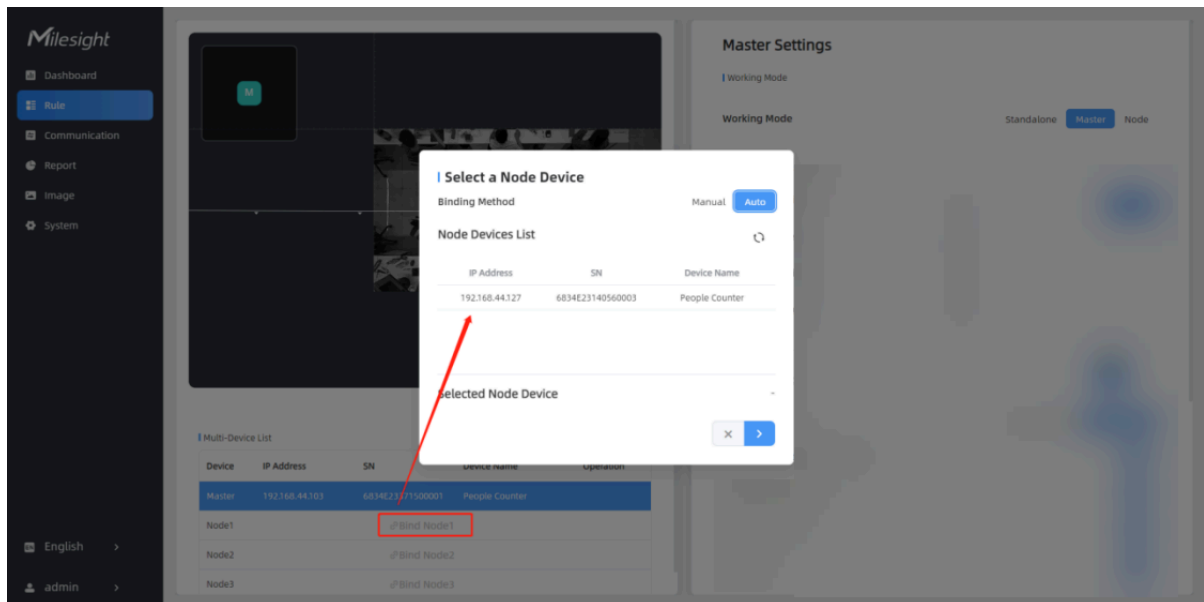

3. Select a node device to be added.

- To select a node device manually:

- a. Click **Manual**.
- b. Enter an IP address, HTTP port, user name or password in the corresponding text box.
- c. Click . The **Bind the Node Device** page is displayed.

- To select a node device automatically:

- a. Click **Auto**. Then the device automatically uses the multicast protocol to discover the unbound node devices within the same local network. The discovered devices are listed in **Node Devices List**.
- b. Select the node device to be added and click . The **Confirm Authorization** dialog box is displayed.

Confirm Authorization

Selected Node Device	192.168.44.127
Node Device Username	<input type="text" value="admin"/>
Node Device Password	<input type="password"/>

c. Enter the login password of the node device and click . The **Bind the Node Device** page is displayed.

Bind the Node Device

Stitch Device Frame Frame Overlapping Frame Non-overlapping

Node Device Deployment Parameters

Installation Height mm(2000-6000)

Stitch Device Frame

Selected Node Device: 192.168.44.105

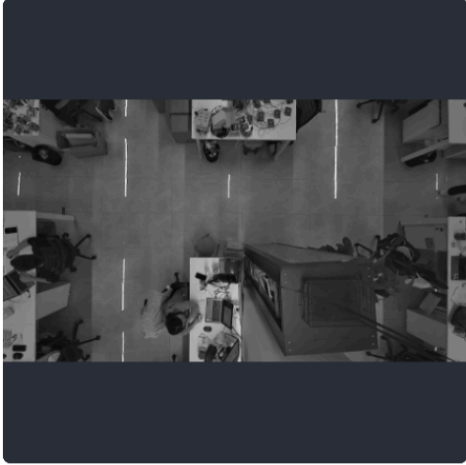

Stitching Point: (0/4)

Selected Stitched Device: -



Please select the device on the right side for frame stitching first

Stitched Device

-
-
-
-
-
-
-
-
-
-

Stitching Point: (0/4)

Tips:

- After image stitching, the device will clear the historical heatmap data.
- Please draw four points for each device to stitch device frame.
- The points can only be drawn on the floor in the frame.
- Please arrange the stitching points in a shape of a quadrangle.
- Please place the points as far from each other as possible, without being too close to the edges of the image.

Bind the Node Device to the Master Device

1. Select **Frame Overlapping** or **Frame Non-overlapping** stitching connection as needed.

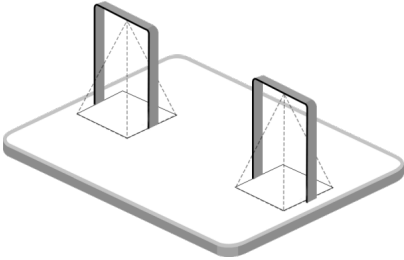
Stitch Method	Description	Illustration
Frame Non-overlapping	<p>Device coverage does not require overlapping areas; only the areas of interest need to be covered.</p> <p>It is only available for firmware version 1.0.5 or later.</p>	

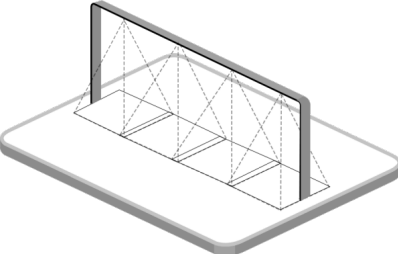
Stitch Method	Description	Illustration
<p>Frame Overlapping</p>	<p>Device coverage requires overlapping areas to ensure complete tracking of targets.</p>	

- If **Frame Overlapping** is selected, follow the steps below:
 - a. In the **Installation Height** area, enter the installation height of the node device or click **Detect** to automatically measure the installation height.

Node Device Deployment Parameters

Installation Height
mm(2000-6000)

3272

Detect

X

✓

- b. Click IP addresses on the right to access the previews of the stitched devices and select the device sharing overlapping coverage areas with this node device.

Stitch Device Frame

Selected Node Device: 192.168.44.104



Stitching Point: (0/4)

Selected Stitched Device: 192.168.44.100



Stitched Device

192.168.44.100

192.168.44.106

192.168.44.103

192.168.44.101

192.168.44.102

Stitching Point: (0/4)

Tips:

- After image stitching, the device will clear the historical heatmap data.
- Please draw four points for each device to stitch device frame.
- The points can only be drawn on the floor in the frame.
- Please arrange the stitching points in a shape of a quadrangle.
- Please place the points as far from each other as possible, without being too close to the edges of the image.

X ✓

- c. On both device previews, define the overlapping coverage areas by mark four calibration points to form a quadrilateral. Then the system automatically performs image stitching based on these points.

i Tip:

The overlapping area should be positioned in locations with minimal target traffic. It is recommended to use objects such as tiles, tables, or tape to mark the stitching points on the ground in the overlapping area.

Stitch Device Frame

Selected Node Device: 192.168.44.104

Stitching Point: (4/4) Point 1 x Point 2 x Point 3 x Point 4 x

Selected Stitched Device: 192.168.44.100

Stitching Point: (4/4) Point 1 x Point 2 x Point 3 x Point 4 x

Stitched Device

- 192.168.44.100
- 192.168.44.106
- 192.168.44.103
- 192.168.44.101
- 192.168.44.102

Tips:

- After image stitching, the device will clear the historical heatmap data.
- Please draw four points for each device to stitch device frame.
- The points can only be drawn on the floor in the frame.
- Please arrange the stitching points in a shape of a quadrangle.
- Please place the points as far from each other as possible, without being too close to the edges of the image.

x
✓



d. (Optional) To modify the calibration points, click x to delete the corresponding point

Point 1 x Point 2 x Point 3 x Point 4 x and mark the point again.

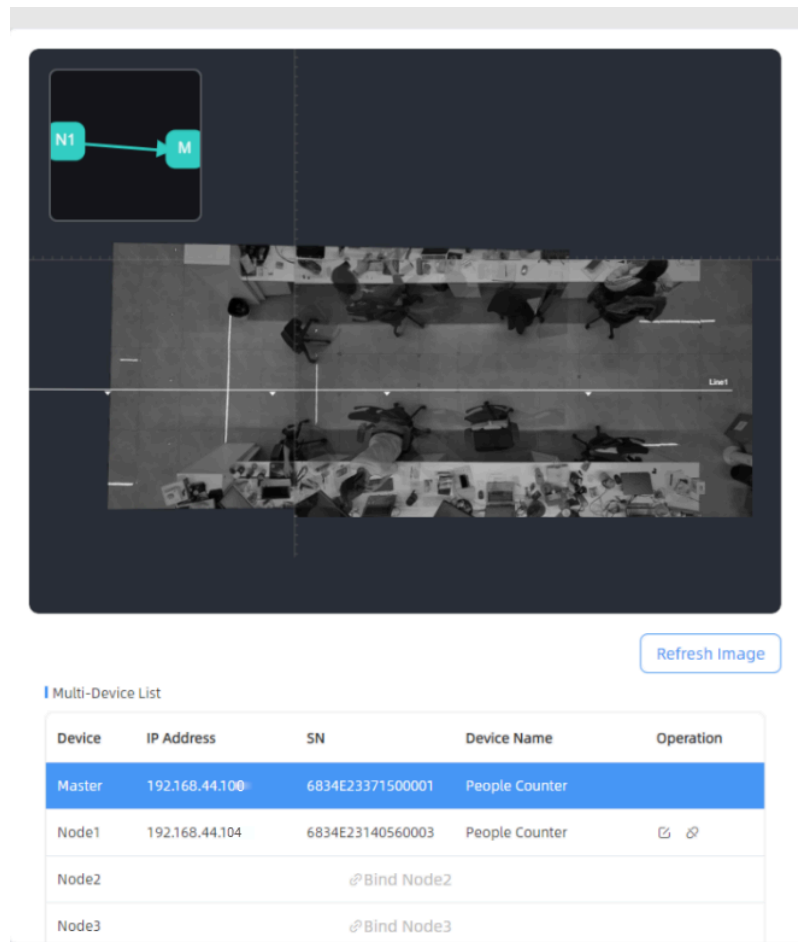
- e. Click  to save the configuration. The node device is listed in the **Multi-Device List**. The following figure shows the effect after the two devices are stitched.



The screenshot displays a camera view of a meeting room with two overlapping frames. A legend in the top left shows a teal box labeled 'N1' with an arrow pointing to a teal box labeled 'M'. Below the camera view is a 'Refresh Image' button. Underneath is a 'Multi-Device List' table:

Device	IP Address	SN	Device Name	Operation
Master	192.168.44.100	6834E23371500001	People Counter	
Node1	192.168.44.104	6834E23140560003	People Counter	 
Node2		@Bind Node2		
Node3		@Bind Node3		

- If **Frame Non-overlapping** is selected, follow the steps below:
 - In the **Installation Height** area, enter the installation height of the node device or click **Detect** to automatically measure the installation height. Configure the image rotation angle relative to the master device.

Bind the Node Device

Stitch Device Frame Frame Overlapping Frame Non-overlapping

Node Device Deployment Parameters

Selected Node Device 192.168.44.104



Installation Height
mm(2000-6000)

Relative Angle
*(-180-180)

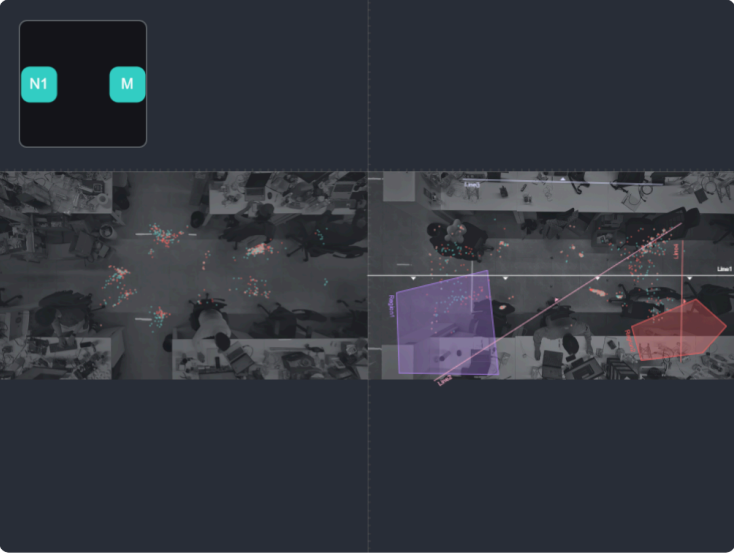
- b. Click  to save the configuration. The node device is listed in the **Multi-Device List**. The following figure shows the effect after the two devices are stitched.



Multi-Device List

Device	IP Address	SN	Device Name	Operation
Master	192.168.44.127	6834E231405600...	People Counter1	
Node1	192.168.44.106	6834E232961600...	People Counter	 
Node2			 Bind Node2	

- c. (Optional) Users can optionally adjust the position of the node device through the preview screen.

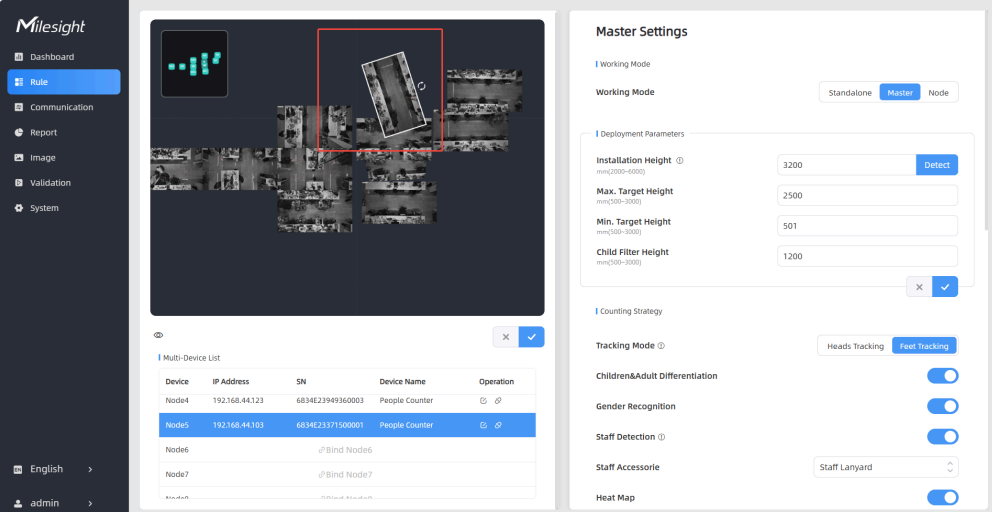

Master Settings

Working Mode: Standalone **Master** Node

Deployment Parameters:

- Installation Height: 3200
- Max. Target Height: 2500
- Min. Target Height: 501
- Child Filter Height: 1200

Counting Strategy:

Tracking Mode: Heads Tracking **Foot Tracking**

Children&Adult Differentiation:



Gender Recognition:

Staff Detection:

Staff Accessorie: Staff Lanyard

Heat Map:

Multi-Device List

Device	IP Address	SN	Device Name	Operation
Node4	192.168.44.123	6834E23949360003	People Counter	 
Node5	192.168.44.103	6834E23371500001	People Counter	 
Node6			@Bind Node6	
Node7			@Bind Node7	

2. To add more devices, follow steps 1 to 5 to stitch them sequentially. A small map in the upper left part of the preview shows the positions of the stitched devices.

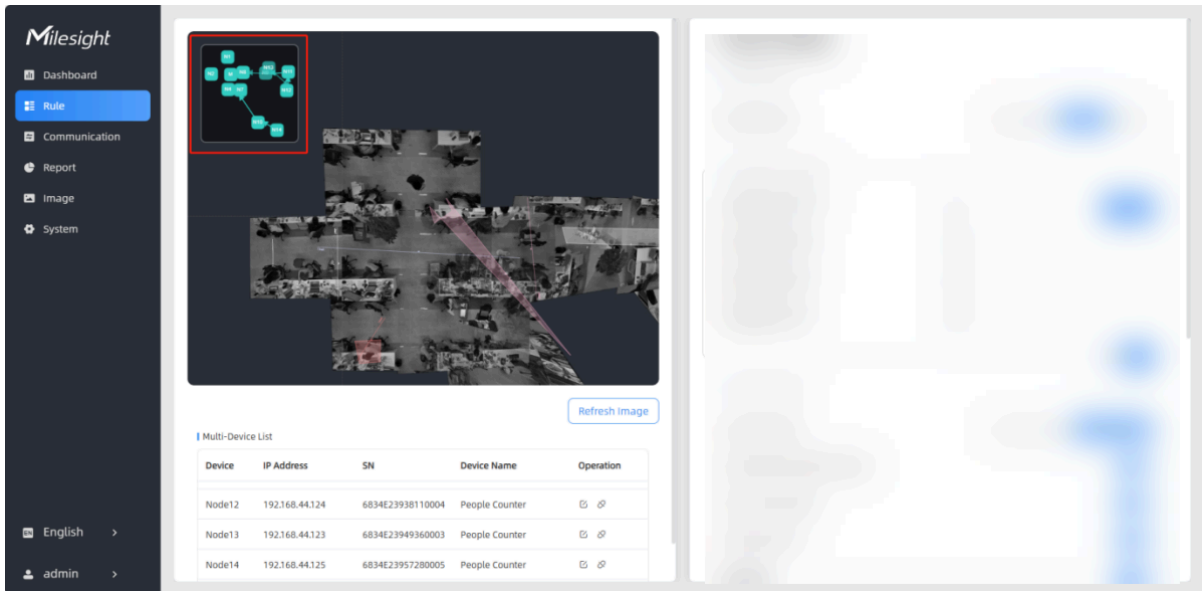

3. (Optional) To disconnect a node device, click  in the corresponding **Operation** area.

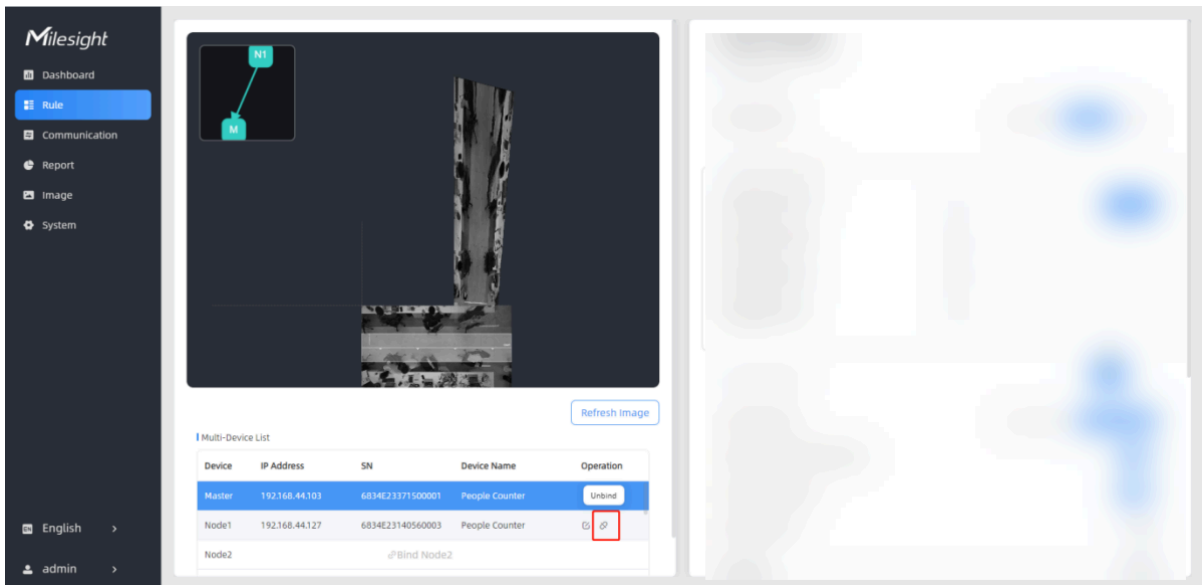

Configure Communication Parameters

This section describes how to configure communication parameters, which includes cellular parameters, TCP/IP parameters, HTTPs parameters, 802.1x protocol parameters, WLAN parameters, recipient and MQTT API parameters.

Configure Network Parameters

This section describes how to configure network parameters, which include cellular parameters (cellular version only), TCP/IP parameters, HTTPs parameters, 802.1x parameters and WLAN parameters.

Configure Cellular Parameters (Cellular Version Only)

This section describes how to configure cellular parameters.

Steps:

1. In the main page, click **Communication** from the left navigation tree.

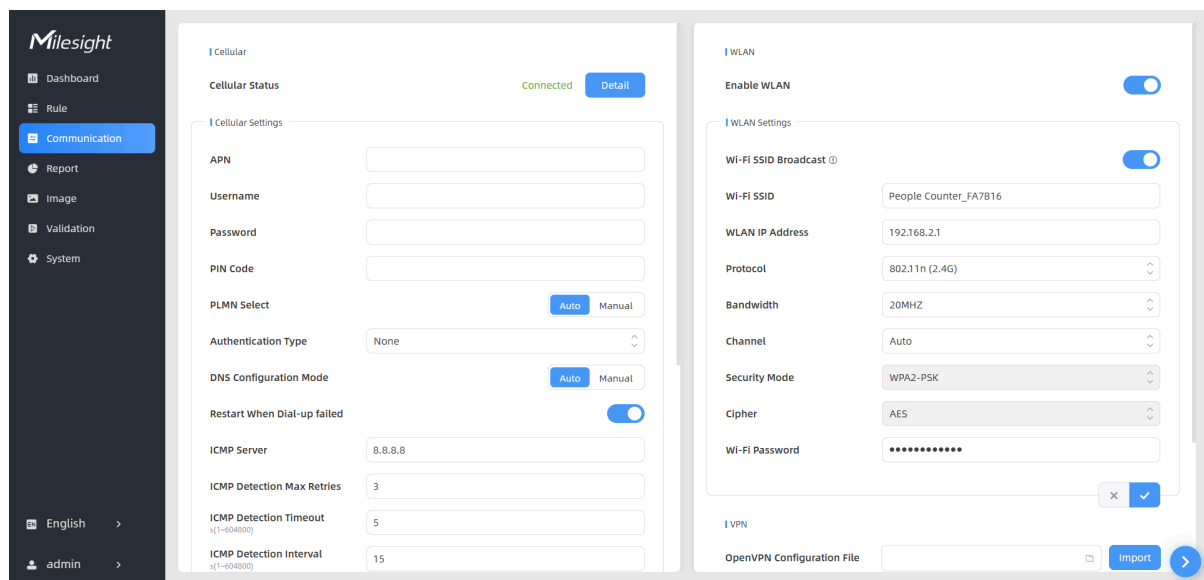

2. In the **Cellular Status** area, click **Detail** to check the cellular status details.
3. In the **Cellular Settings** area, configure cellular parameters as needed. For parameter descriptions, refer to the following table.

Parameters	Description
APN	Access point name for cellular dial-up connection provided by a local ISP. Maximum length: 31 characters.
Username	Username for cellular dial-up connection provided by a local ISP. Maximum length: 31 characters.
Password	Password for cellular dial-up connection provided by a local ISP. Maximum length: 31 characters.
PIN Code	PIN code to unlock the SIM. Length: 4-8 characters.

Parameters	Description
PLMN Select	Select the way to configure the PLMN.
PLMN ID	Manually fill in the PLMN ID.
Authentication Type	Options: None , PAP , CHAP , PAP and CHAP .
Roaming	Enables the Roaming function.
DNS Configuration Mode	Options: Auto and Manual . <ul style="list-style-type: none"> ◦ If DNS Configuration Mode is set to Auto, the device automatically obtains the DNS assigned by the carrier. ◦ If DNS Configuration Mode is set to Manual, both Primary and Secondary DNS server addresses must be entered.
Restart When Dial-up Failed	Enables automatic device restart when multiple dial-up failed.
ICMP Server	Configures the IP address of the ICMP detection server.
ICMP Detection Max Retries	Sets the maximum number of retries when ICMP detection failed.
ICMP Detection Timeout	Configure ICMP detection timeout duration.
ICMP Detection Interval	Configures the ICMP detection interval.

4. Click  to save the configuration.

Configure TCP/IP Parameters

The device use the Ethernet port for data transmission and multi-device stitching. This section describes how to configure TCP/IP parameters.

For the cellular version, data reporting is depended on the current network. When both cellular network and Ethernet connections are available, the device prioritizes cellular networks for data reporting.

Steps:

1. In the main page, click **Communication** from the left navigation tree.

TCP/IP

IP Assignment Manual Automatic (DHCP)

IP Address Test

Subnet Mask

Default Gateway

Primary DNS Server

Secondary DNS Server

✕ ✓

2. In the **TCP/IP** area, configure TCP/IP parameters as needed. For parameter descriptions, refer to the following table.

Parameters	Description
IP Assignment	<p>Sets the IP assignment method. Options: Manual or Automatic (DHCP).</p> <ul style="list-style-type: none"> - If Manual is selected, the following parameters need to be configured manually. - If Automatic (DHCP) is selected, the device will automatically be assigned an IP address and configuration parameters. <div style="background-color: #e0f2f1; padding: 10px; border-radius: 5px;"> <p> Note: The hostname displayed on the server will be updated to match the device name, with the change taking effect within 20 seconds or upon DHCP lease expiration.</p> </div>
IP Address	Sets the IPv4 address of the Ethernet port. Default value: 192.168.5.220 .
Test	Click Test to check for IP address conflicts.
Subnet Mask	Sets the netmask for the Ethernet port.

Parameters	Description
Default Gateway	Sets the gateway for the Ethernet port's IPv4 address.
Primary DNS Server	Sets the primary IPv4 DNS server.
Secondary DNS Server	Sets the secondary IPv4 DNS server.

3. Click  to save the configuration.

Configure HTTPs Parameters (PoE Version Only)

HTTPs encrypts data transmitted between a web browser and a server. It ensures confidentiality, verifies server authenticity, and protects data integrity against tampering. This section describes how to configure HTTPs parameters to ensure secure communication.

Steps:

1. In the main page, click **Communication** from the left navigation tree.

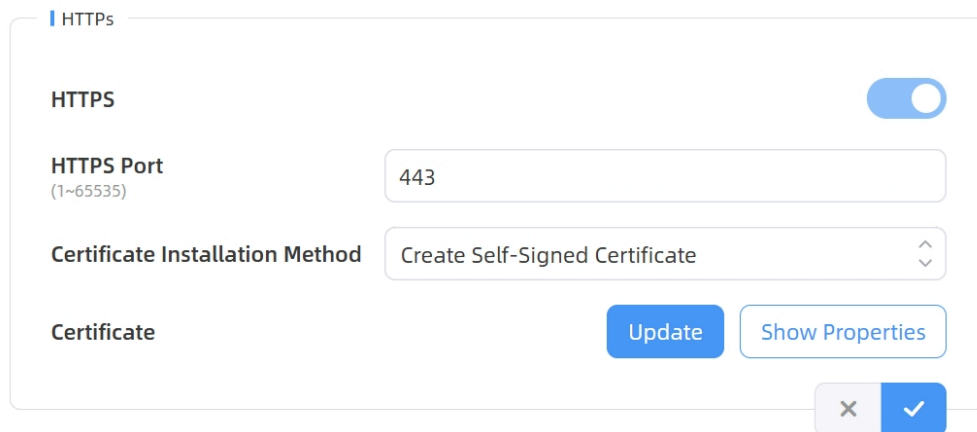

The screenshot shows the configuration page for HTTPs. At the top left, there is a tab labeled 'HTTPs'. The main content area includes:

- A toggle switch for 'HTTPS' which is currently turned on.
- A text input field for 'HTTPS Port' with the value '443' and a range indicator '(1~65535)' below it.
- A dropdown menu for 'Certificate Installation Method' with 'Create Self-Signed Certificate' selected.
- Two buttons: 'Update' and 'Show Properties'.
- At the bottom right, there are two small buttons: a close button (x) and a save button (checkmark).

- In the **HTTPs** area, enable **HTTPS**.
- Set **HTTPS Port** to configure the web GUI login port. It is **443** by default.
- Select **Certificate Installation Method**. Options: **Create Self-Signed Certificate**, **Direct Installation Certificate**.
- Perform the following operations as needed.

If	Do
<p>- If Certificate Installation Method is set to Create Self-Signed Certificate</p>	<p>a. Click Update. The Update Certificate Information dialog box is displayed.</p> <div data-bbox="860 367 1250 745"> <p>Update Certificate Information</p> <p>Country (C) <small>Two-letter Country Code</small> <input type="text" value="US"/></p> <p>State (ST) <input type="text" value="Some State"/></p> <p>Locality (L) <input type="text" value="Some Location"/></p> <p>Organization (O) <input type="text" value="Internet Widgits Pty Ltd"/></p> <p>Organization Unit (OU) <input type="text" value="Internet Widgits Pty Ltd"/></p> <p>Common Name (CN) <input type="text" value="People Counter"/></p> <p>Validity Period <small>days(1-625)</small> <input type="text" value="397"/></p> <p><input type="button" value="x"/> <input type="button" value="✓"/></p> </div> <p>b. Update certificate information as needed and click . The certificate is uploaded.</p> <p>c. (Optional) To check certificate properties, click Show Properties. The Certificate Properties information box is displayed.</p> <div data-bbox="860 997 1250 1354"> <p>Certificate Properties</p> <p>Issued To CN = People Counter O = Internet Widgits Pty Ltd OU = Internet Widgits Pty Ltd</p> <p>Issued From CN = People Counter O = Internet Widgits Pty Ltd OU = Internet Widgits Pty Ltd</p> <p>Validity Period Jan 17 05:47:37 1970 GMT Feb 18 05:47:37 1971 GMT</p> <p><input type="button" value="x"/></p> </div>
<p>- If Certificate Installation Method is set to Direct Installation Certificate</p>	<p>a. Click File to upload the CA certificate file.</p> <p>b. (Optional) To check certificate properties, click Show Properties. The Certificate Properties information box is displayed.</p>

If	Do
	<div data-bbox="868 268 1253 630"> <p>Certificate Properties</p> <p>Issued To: CN = People Counter O = Internet Widgits Pty Ltd OU = Internet Widgits Pty Ltd</p> <p>Issued From: CN = People Counter O = Internet Widgits Pty Ltd OU = Internet Widgits Pty Ltd</p> <p>Validity Period: Jan 17 05:47:37 1970 GMT Feb 18 05:47:37 1971 GMT</p> <p style="text-align: right;">x</p> </div> <p data-bbox="673 682 1372 745">c. (Optional) Enter the certificate key password to parse the certificate.</p>

6. Click  to save the configuration.

Configure 802.1x Protocol Parameters (PoE Version Only)

The IEEE 802.1x is an authentication protocol to allow access to networks with the use of RADIUS server. This section describes how to configure 802.1x protocol parameters.

Steps:

1. In the main page, click **Communication** from the left navigation tree.

802.1x

Enable

Authentication Type: MD5-Challenge

EAPOL Protocol Version: 802.1x-2001

Identity:

Password:

Confirm Password:

x

2. In the **802.1x** area, configure 802.1x parameters as needed. For parameter descriptions, refer to the following table.

Parameters	Description
Enable	Enables/disables 802.1x authentication.
Authentication Type	Options: MD5-Challenge, EAP-TLS.

3. Select Authentication Type, configure the following parameters as needed.

- If Authentication Type is set to **MD5-Challenge**:

Parameters	Description
EAPOL Protocol Version	Options: 802.1x-2001, 802.1x-2004.
Identity	Sets the identity for 802.1x authentication.
Password	Sets the password for 802.1x authentication.
Confirm Password	Enter the password again.

- If Authentication Type is set to **EAP-TLS**:

Parameters	Description
EAPOL Protocol Version	Options: 802.1x-2001, 802.1x-2004.
Identity	Sets the identity for 802.1x authentication.
CA File	Upload the CA file.
Client Certificate File	Upload the certificate file.
Client Key File	Upload the client keys.
Key Password	Sets the password for the client key.

Configure WLAN Parameters

This section describes how to configure WLAN parameters.

Steps:

1. In the main page, click **Communication** from the left navigation tree.

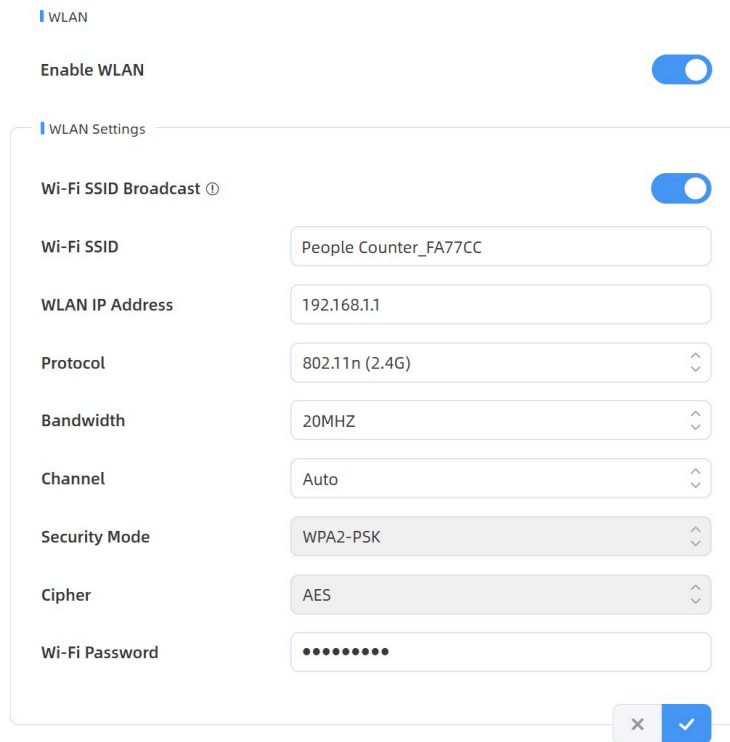

2. In the **WLAN** area, click to enable the Wi-Fi function.

3. In the **WLAN Settings** area, configure WLAN parameters as needed. For parameter descriptions, refer to the following table.

Parameters	Description
Wi-Fi SSID Broadcast	When disabled, the WiFi SSID will not be automatically discovered, but can still be connected by manually entering the SSID.
Wi-Fi SSID	Unique Wi-Fi access point identifier for this device. Format: <code>People Counter_xxxxxx</code> . It can be found on the device label.
WLAN IP Address	WLAN IP address for web access. Default value: 192.168.1.1 .
Protocol	Options: 802.11b (2.4G) , 802.11n (2.4G) and 802.11n (2.4G) .
Bandwidth	Options: 20MHz , 40MHz .
Channel	Wireless channel. Range: Auto, 1-11.
Security Mode	Fixed value: WPA2-PSK .
Cipher	Fixed value: AES .

Parameters	Description
Wi-Fi Password	Customize the password. It must include numbers, lowercase letters, uppercase letters and special characters. Range: 8-63 characters.

4. Click  to save the configuration.

Configure OpenVPN Parameters

This section describes how to configure OpenVPN parameters.

Steps:

1. In the main page, click **Communication** from the left navigation tree.



2. In the **VPN Settings** area, configure VPN parameters as needed. For parameter descriptions, refer to the following table.

Parameters	Description
OpenVPN Configuration File	Import the ".conf" or ".ovpn" format OpenVPN client configuration profile.
Status	Show the connection status of the device and the VPN server: Disconnected, Connecting or Connected.
Device Virtual IP	Show the virtual IP of device.
Sever Virtual IP	Show the virtual IP of VPN Server.
Duration	Show the connection duration.

Add Data Recipients

The device supports the addition of data recipients using HTTP(s) or MQTT(s) protocols. It proactively pushes data to configured recipients according to the specified reporting scheme. For detailed data format specifications, refer to [Uplink Data](#). Additionally, device configuration and people counting data retrieval are available through CGI interfaces. For details, refer to [Milesight AI Stereo Vision People Counting Sensor API Specification](#). This section describes how to add data recipients.

Steps:

1. In the main page, click **Communication** from the left navigation tree.

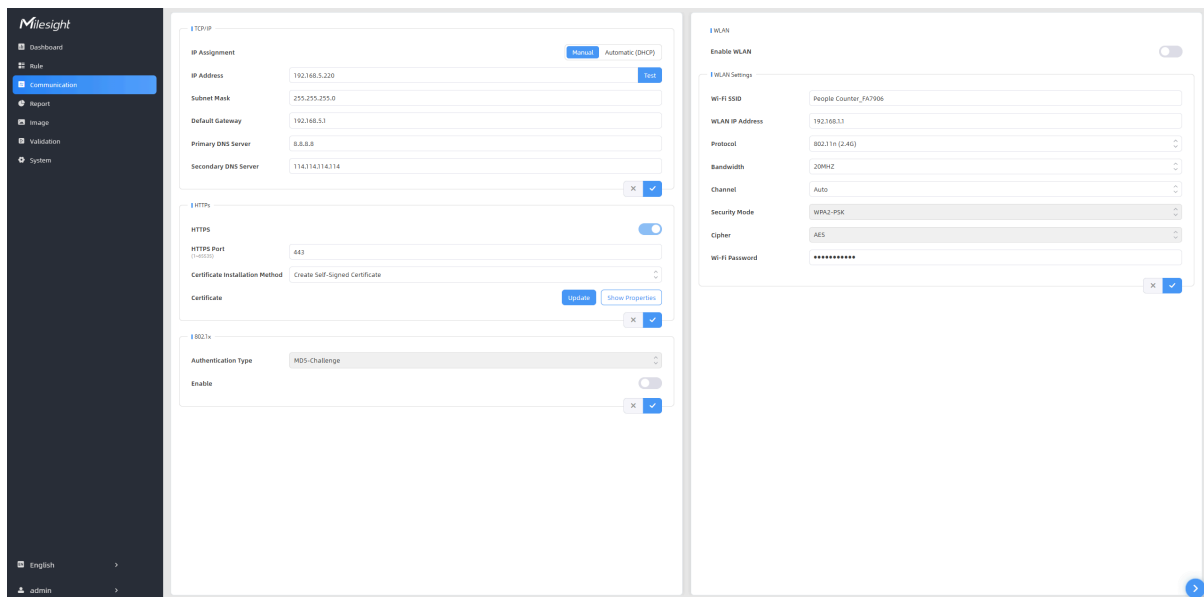

2. Click  in the lower right corner. The **Recipient** page is displayed.

Recipient Name	URL/Host	Protocol	Status	Operation
+ Add				

3. Click **+ Add**. The **Recipient Settings** dialog box is displayed. You can add up to 8 recipients.

Recipient Settings

Recipient Name	<input type="text" value="Recipient"/>
Report Protocol	<input type="text" value="MQTT"/>
Host	<input type="text"/>
Port (1~65535)	<input type="text"/>
ClientID	<input type="text"/>
Username	<input type="text"/>
Password	<input type="text"/>
Topic ⓘ	<input type="text"/>
QoS	<input type="text" value="QoS 0"/>
TLS	<input checked="" type="checkbox"/>

4. Configure the recipient parameters as needed.
 - a. In the **Recipient Name** text box, enter a recipient name.
 - b. Set **Report Protocol** to **HTTP(s)** or **MQTT** as needed.
 - c. Perform the following operations as needed.

- If **Report Protocol** is set to **HTTP(s)**, configure the following parameters.

Parameters	Description
URL	Data Recipient URL. It configures the target URL to receive people counting data in JSON format. This device supports multiple third-party platforms. For the supported platforms, refer to Milesight official website .
Connection Test	Click Test to send test message to a URL to check connectivity.
Username	User name used for authentication.
Password	Password used for authentication.

- If **Report Protocol** is set to **MQTT**, configure the following parameters.

Parameters	Description
Host	Address of the MQTT broker to receive data. This device supports multiple third-party platforms. For the supported platforms, refer to Milesight official website .
Port	Port of the MQTT broker used to receive data.
Client ID	Unique client identifier for the MQTT server. It must be unique across all connections to the same server and is essential for managing message delivery at QoS levels 1 and 2.
Username	User name for MQTT broker authentication.
Password	Password for MQTT broker authentication.
Topic	<p>Topic name used for publishing messages. An example topic name is as follows:</p>  <p>The following placeholders are dynamically replaced with device information upon subscription.</p> <ul style="list-style-type: none"> - \$devsn: Device SN - \$prdmd: Product model - \$devid: Customized device ID - \$siteid: Customized site ID
QoS	Options: QoS 0 , QoS 1 , and QoS 2 .
TLS	Enables TLS encryption for MQTT communication.
Certificate Type	Options: CA Signed Server or Self Signed .

Parameters	Description
	<p>If Certificate Type is set to CA Signed Server, server verification is performed using a CA certificate that is pre-installed on the device.</p> <p>If Certificate Type is set to Self Signed, click  in the CA File, Client Certificate File, and Client Key File areas to upload the corresponding files for identity verification.</p>

5. Click  to save the configuration. The **Report Strategy** dialog box is displayed.

Report Strategy

Trigger Report

Trigger Report Cooldown

Trigger Report Schedule

Periodic Report

Periodic Report Scheme On the Dot From Now On

Period 15min ^ v

Real-time Data Report

Data Retransmission

Customize Report Content

x
<
✓

6. Configure the report strategy parameters as needed. For parameter descriptions, refer to the following table.

Parameter	Description
Trigger Report	Enables real-time reporting when the line crossing count or region count changes.
Trigger Report Cooldown	Enable this option to prevent frequent trigger reports when foot traffic is high. The cumulative data will be reported after the cooldown period.

Parameter	Description
	<p>Cooldown Period: During the cooldown period, trigger events are not reported. Once the cooldown period ends, reporting will resume.</p>
<p>Trigger Report Schedule</p>	<p>Events are reported only if they occur within up to five configurable time periods. If a cooldown is enabled, reporting occurs only if the cooldown ends within a work period. No reporting occurs outside the defined periods.</p>
<p>Periodic Report</p>	<p>Enables periodic reporting of line crossing and region counting data.</p>
<p>Periodic Report Scheme</p>	<p>Options: On the Dot or From Now On.</p> <ul style="list-style-type: none"> ◦ If Periodic Report Scheme is set to On the Dot, select the interval from the Period drop-down list as needed. Then the device reports at the top of each hour. For example: <ul style="list-style-type: none"> ▪ 1-hour interval: Reports occur on the hour (00:00, 01:00, 02:00...) ▪ 10-minute interval: Reports occur at 10-minute marks (00:10, 00:20, 00:30...) ◦ If Periodic Report Scheme is set to From Now On, enter an interval value in the Period text box as needed. Then the device initiates periodic reporting immediately upon activation and regularly report at the configured interval.
<p>Real-time Data Report</p>	<p>When real-time reporting is required, enable this feature. Once enabled, the device reports data at a fixed interval of 500 ms. High-frequency reporting may increase network traffic and server load. For details on the reporting content, please refer to Customize Report Content.</p>
<p>Data Retransmission</p>	<p>If enabled, the device automatically transmits all buffered data packets from the offline period once the network connection is restored. Each recipient endpoint supports a maximum capacity of 50,000 data records.</p>
<p>Customize Report Content</p>	<p>Enables report content customization. Select the required content to avoid data redundancy.</p>

Parameter	Description
	<div style="text-align: right;"> <input checked="" type="checkbox"/> Customize Report Content </div> <ul style="list-style-type: none"> <input checked="" type="checkbox"/> Device Info ◀ <input type="checkbox"/> Time Info ◀ <input checked="" type="checkbox"/> Line ◀ <input checked="" type="checkbox"/> Region ◀ <input checked="" type="checkbox"/> Attention Region ◀ <input checked="" type="checkbox"/> I/O ◀ <input checked="" type="checkbox"/> Alarm ◀ <input checked="" type="checkbox"/> Live Data ◀

7. Click to save the configuration. The added recipient is displayed in the **Recipient** page.

Recipient

Recipient Name	URL/Host	Protocol	Status	Operation
Recipient	https://webhook.site/f44e61bc-d755-4a4d-...	HTTP	Disconnect	
Recipient	192.168.44.125	MQTT	Disconnect	
+ Add				

8. (Optional) To edit or delete the recipient, click or .

Configure BACnet Parameters (PoE Version Only)

The device provides a BACnet/IP protocol connection to the BMS system, enabling data exchange and communication between devices within building automation systems as BACnet Server.

This section describes how to configure BACnet parameters. It applies for the PoE version only.

Steps:

1. In the main page, click **Communication** from the left navigation tree.

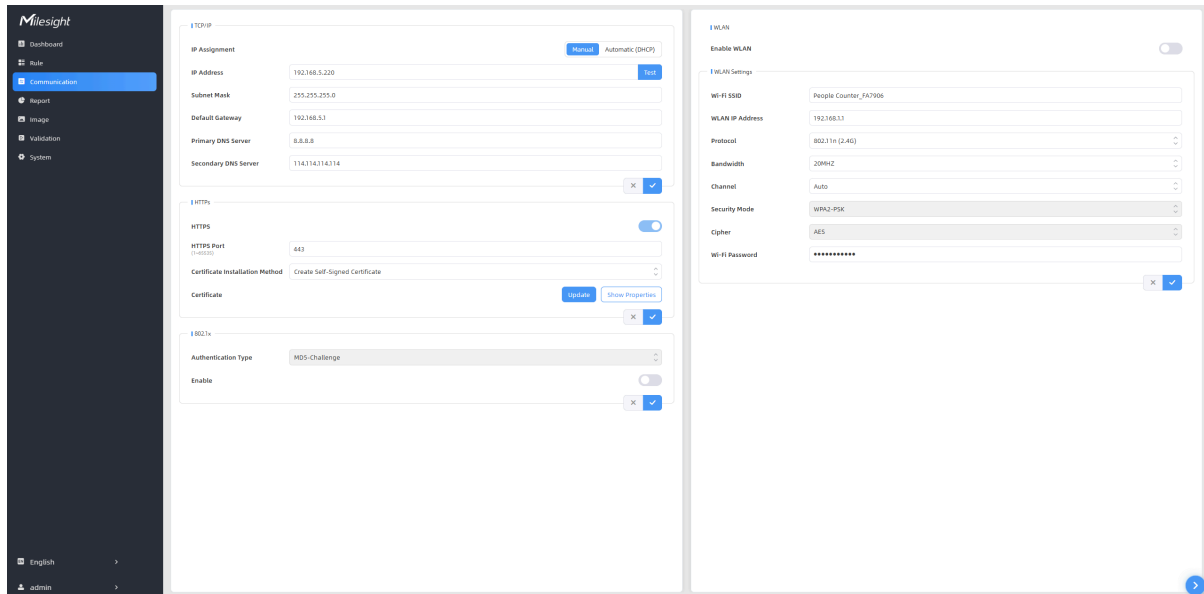

2. Click  in the lower right corner and click "BACnet". The **BACnet** page is displayed.

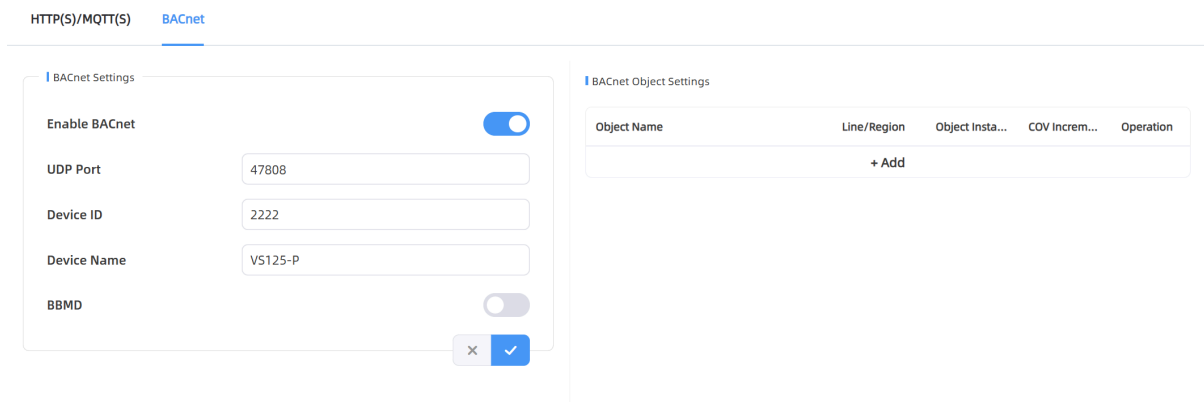

3. Configure the BACnet settings parameters as needed.

Parameters	Description
UDP Port	Set the communication port for BACnet/IP. Range: 1-65535. The default port is 47808.
Device ID	The unique BACnet device identifier that must not conflict with other devices. The default value is the 6 th to 11 th characters of SN.
Device Name	The name to represent the device.

Parameters	Description
BBMD	<p>Enable BBMD (BACnet/IP Broadcast Management Device) if BACnet devices of different network subnets should work together.</p> <p>IP Address: Fill in the IP address of BBMD device or external device registrar.</p> <p>IP Port: Fill in the UDP/IP port for external device registration.</p> <p>Time To Live: Number of seconds used on external device registration.</p>

Click  to save the configuration.

4. Click **+ Add**. The **BACnet Object Settings** dialog box is displayed.

Add Object

Object Name Cumulative Individuals In-Line1

Object Select

Object Type

Object Unit

Line

Object Instance No.

Object Description

COV

Parameters	Description
Object Name	Show the name of the BACnet object.
Object Select	Select the variable data for the device as an object.
Line/Region	Select one of the detection line or region which object you select.

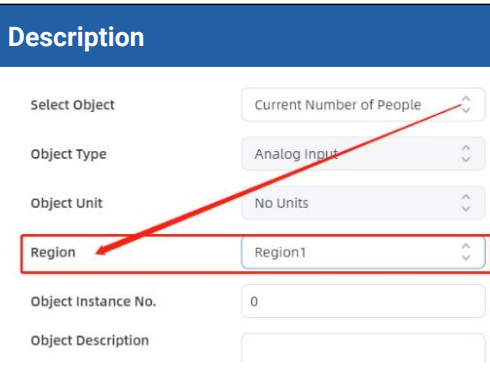
Parameters	Description
	 <p>Select Object: Current Number of People</p> <p>Object Type: Analog Input</p> <p>Object Unit: No Units</p> <p>Region: Region1</p> <p>Object Instance No.: 0</p> <p>Object Description:</p>
Object Instance No.	Set the object instance number.
Object Description	Set the object description.
COV	When enabled, a notification is sent when the object value changes of new value to BACnet client.
COV Increment	Set the minimum change value for the current object.

5. Click  to save the configuration.

Configure MQTT API Parameters (Cellular Version Only)

The device provides an MQTT API that receives [downlink commands](#) for retrieving people counting data and modifying device configuration. This section describes how to configure MQTT API parameters. It applies for the cellular version only.

Steps:

1. In the main page, click **Communication** from the left navigation tree.

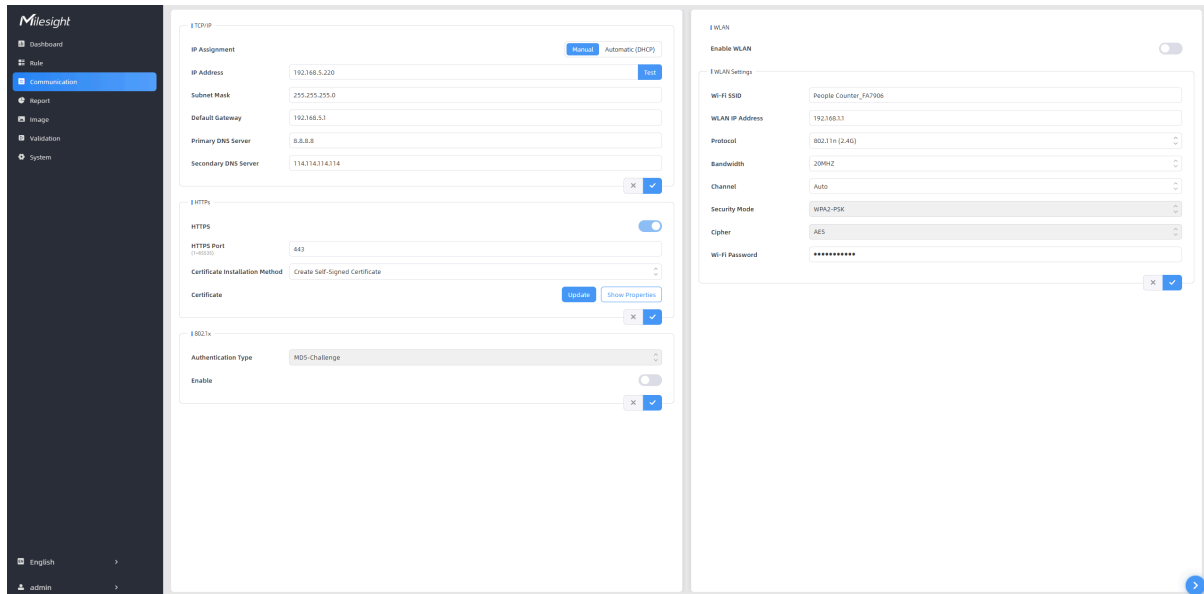

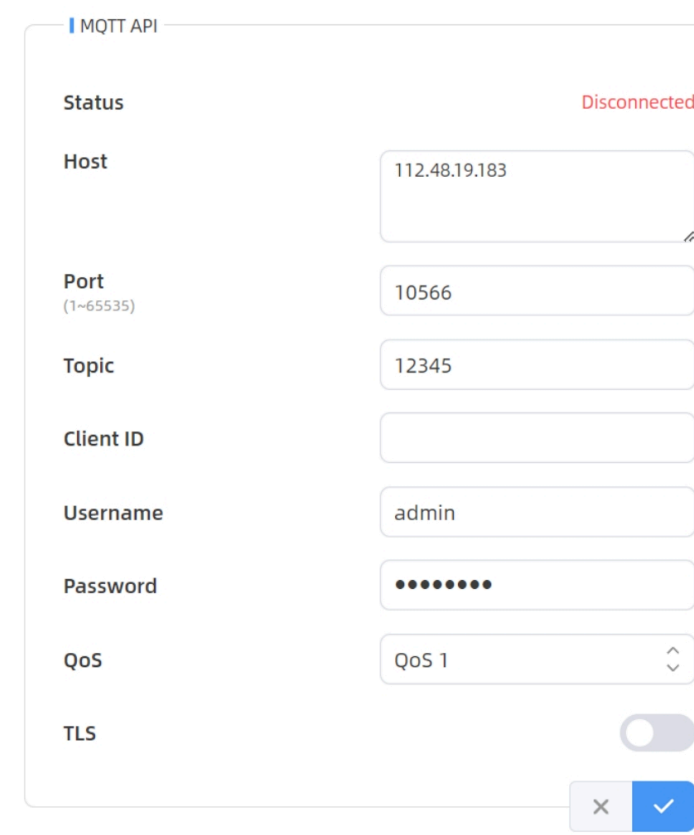

2. Click  in the lower right corner. The **MQTT API** page is displayed.



3. Configure the following parameters as needed. For parameter descriptions, refer to the following table.

Parameters	Description
Status	Connection status between the device and the MQTT broker.
Host	Address of the MQTT broker to receive data.
Port	Port of the MQTT broker to receive data.
Topic	<p>Topic name used for publishing messages. A topic name example is as follows:</p> <p>Topic ⓘ <input type="text" value="device/downlink_config"/></p> <p>The following placeholders are dynamically replaced with device information upon subscription.</p> <ul style="list-style-type: none"> - \$devsn: Device SN - \$prdmd: Product model - \$devid: Customized device ID - \$siteid: Customized site ID
Client ID	Unique client identifier for the MQTT server. It must be unique across all connections to the same server and is essential for managing message delivery at QoS levels 1 and 2.
Username	User name for MQTT broker authentication.
Password	Password for MQTT broker authentication.
QoS	Options: QoS 0 , QoS 1 , and QoS 2 .
TLS	Enables the TLS encryption in MQTT communication.
Certificate Type	This parameter is displayed only after TLS is enabled. Options: CA Signed Server or Self Signed .

Parameters	Description
	<p>If Certificate Type is set to CA Signed Server, server verification is performed using a CA certificate that is pre-installed on the device.</p> <p>If Certificate Type is set to Self Signed, click  in the CA File, Client Certificate File, and Client Key File areas to upload the corresponding files for identity verification.</p>

4. Click  to save the configuration.

Generate Reports

Upon configuration of both basic counting and advanced AI recolonization functions, the device provides multiple data presentation options such as the dashboard, reports and command line outputs.







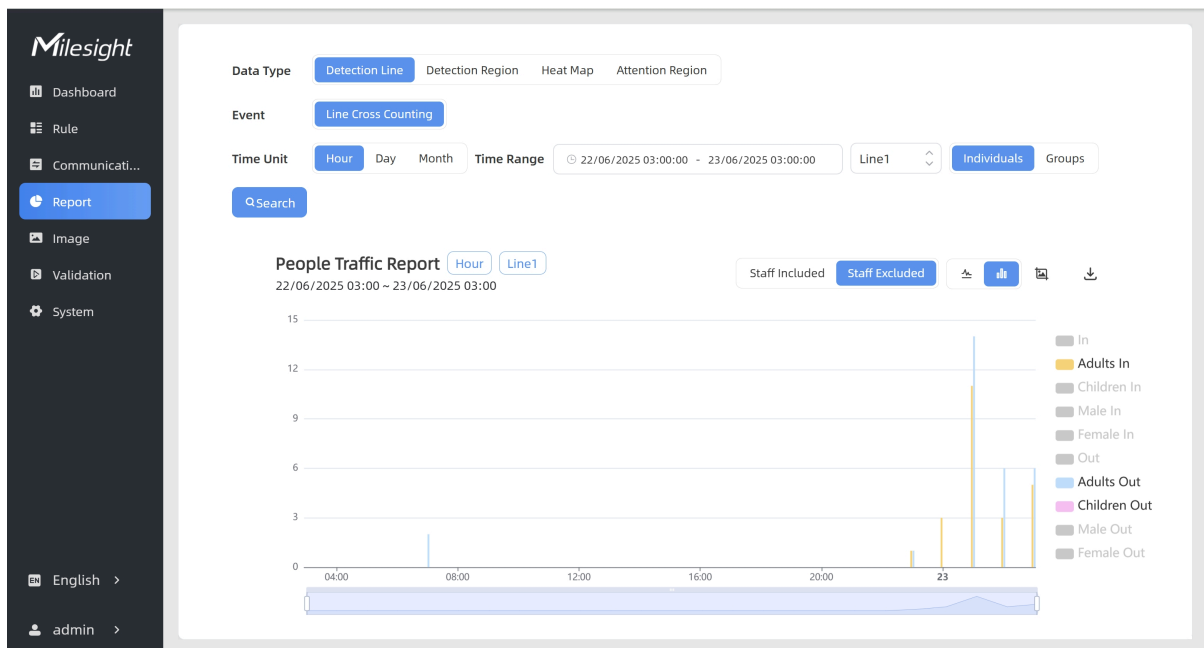



The device supports visual line chart or bar chart generation to display people traffic and supports report exporting. Before using this feature, do ensure that the device time is correct on **System** page.













Steps:





1. In the main page, click **Report** from the left navigation tree.



2. Select the data type for report generation. Options: **Detection Line, Detection Region, Heat Map, Attention Region, I/O.**
3. Perform any of the following operations as needed.

If	Do
<p>If Data Type is set to Detection Line</p>	<ol style="list-style-type: none"> a. Set Time Unit and Time Range. b. Select a line from the drop-down list. c. Select Individuals or Groups as needed. d. Click Search. The People Traffic Report is displayed correspondingly. e. Click Staff Included or Staff Excluded to include/exclude staff counting values in the report. f. Click  or  to display the report in the corresponding form. g. Click  to download the chart screenshot. h. Click  to export the historical traffic data to a CSV file. The system supports exporting up to 1,000,000 data records per CSV file. i. Click on any category on the following figure to hide it from the chart. <ul style="list-style-type: none">  In  Adults In  Children In  Out  Adults Out  Children Out
<p>If Data Type is set to Detection Region</p>	<ol style="list-style-type: none"> a. Select an event. Options: Region People Counting, Dwell Time Detection b. Perform any of the operations as needed. <ul style="list-style-type: none"> ▪ If Event is set to Region People Counting: set Time Range and select a region from the drop-down list. ▪ If Event is set to Dwell Time Detection: set Time Range, Min. Value, Bin Width and Number Of Bins and select a region from the drop-down list. c. Click Search. The People Counting Report or Total Dwell Time Report is displayed correspondingly.

If	Do
	<p>d. Click Staff Included or Staff Excluded to include/exclude staff counting values in the report.</p> <p>e. Click  to download the chart screenshot.</p> <p>f. Click  to export the historical traffic data to a CSV file. The system supports exporting up to 1,000,000 data records per CSV file.</p> <p>g. Click on any category on the following figure to hide it from the chart.</p> <ul style="list-style-type: none">  Count  Adults Count  Children Count  Male Count  Female Count
<p>If Data Type is set to Heat Map</p>	<p>a. Select an event. Options: Motion Heatmap, Dwell Heatmap.</p> <p>b. Set Time Range.</p> <p>c. Click Search. The Motion Heatmap Report or Dwell Heatmap Report is displayed correspondingly.</p> <p>d. Click  to download the chart screenshot.</p> <p>e. Click  to refresh image.</p>
<p>If Data Type is set to Attention Region</p>	<p>a. Set Time Range, Min. Value, Bin Width, and Number Of Bins and select an attention region.</p> <p>b. Click Search. The Attention Time Report is displayed correspondingly.</p> <p>c. Click Staff Included or Staff Excluded to include/exclude staff counting values in the report.</p> <p>d. Click  or  to display the report in the corresponding form.</p> <p>e. Click  to download the chart screenshot.</p> <p>f. Click  to export the historical traffic data to a CSV file. The system supports exporting up to 1,000,000 data records per CSV file.</p>

If	Do
	<p>g. Click on any category on the following figure to hide it from the chart.</p> <ul style="list-style-type: none"> ■ In ■ Adults In ■ Children In ■ Out ■ Adults Out ■ Children Out
<p>If Data Type is set to I/O</p>	<p>a. Set Time Unit and Time Range.</p> <p>b. Click Search. The Digital Input Trigger Count Report is displayed correspondingly.</p> <p>c. Click  or  to display the report in the corresponding form.</p> <p>d. Click  to download the chart screenshot.</p> <p>e. Click  to export the historical traffic data to a CSV file. The system supports exporting up to 1,000,000 data records per CSV file.</p>

Configure Image Parameters

The device has great lighting adaptability that allows it to operate properly in low light and even complete darkness. It supports day and night mode switching based on the no-photosensitive scheme. This section describes how to configure image parameters.

Steps:

1. In the main page, click **Image** from the left navigation tree.

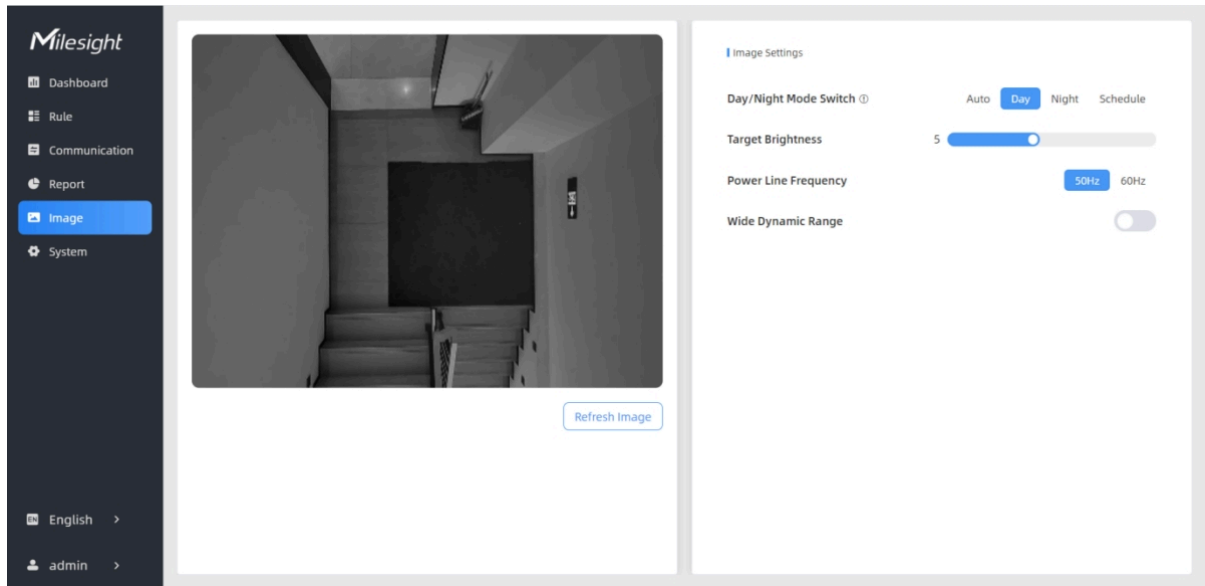

2. In the **Image Settings** area on the right, configure the following parameters as needed.

Parameters	Description
Day/Night Mode Switch	<p>Set image mode. Options: Auto, Day, Night and Schedule.</p> <ul style="list-style-type: none"> - Auto: Automatic switch between day and night modes according to image brightness. - Day: Black and white mode. - Night: Infrared based black and white mode. - Schedule: Switches between day and night modes based on the configured schedule.
Sensitivity	<p>Set the sensitivity of the automatic day and night mode switching. The higher the sensitivity is, the easier to switch between day and night modes.</p>
Night Mode Duration	<p>Set the night mode duration.</p>
Target Brightness	<p>Set the brightness of the target to make image clearer. The higher brightness is, the brighter the target brightness is.</p>

Parameters	Description
Power Line Frequency	Select the frequency to avoid the image flashing. Options: 50Hz , 60Hz .
Wide Dynamic Range	Enable or disable Wide Dynamic Range . Enabling it can capture more detail in scenes where light conditions vary greatly.

3. (Optional) When multi-devices are stitched, you can select the devices that need to be configured and perform batch operations.

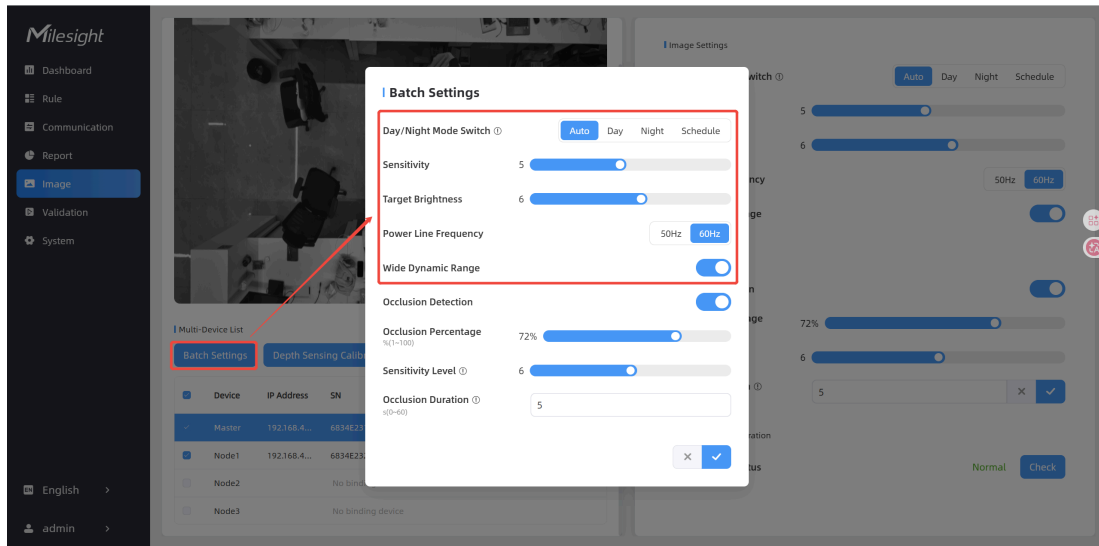

4. Click **Refresh Image** to check image changes.

Configure Occlusion Alarm Settings

Occlusion Alarm can be enabled to detect when the sensor is occluded. Alarms are issued when occlusion occurs, and notification of deactivation is given when occlusion is lifted.

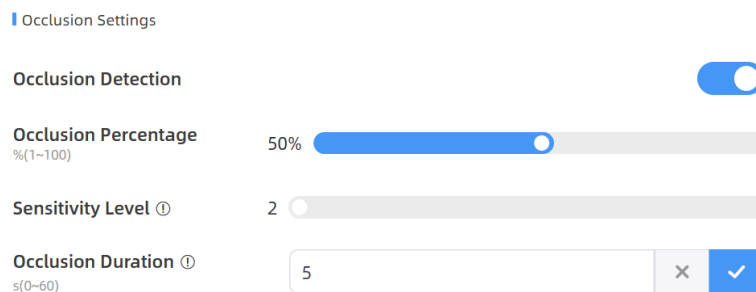

1. Enable **Occlusion Detection**.
2. Configure the following parameters as needed. When multi-device stitching mode is enabled, the occlusion setting parameters of the master and node devices are synchronized. Regardless of which device is masked, the master device will trigger the alarm.

Parameters	Description
Occlusion Percentage	Drag the progress bar, adjust the threshold for the percentage of the entire field of view that must be occluded to trigger an alarm. Default: 50%.
Sensitivity Level	Drag Sensitivity Level progress bar, adjust the sensitivity of the occlusion trigger. The higher the level, the easier it is to detect occlusion, but the false alarm rate increases. Default: 2.
Occlusion Duration	Fill in the value to set the duration that the sensor must be obscured.

3. (Optional) When multi-devices are stitched, you can select the devices that need to be configured and perform batch operations.

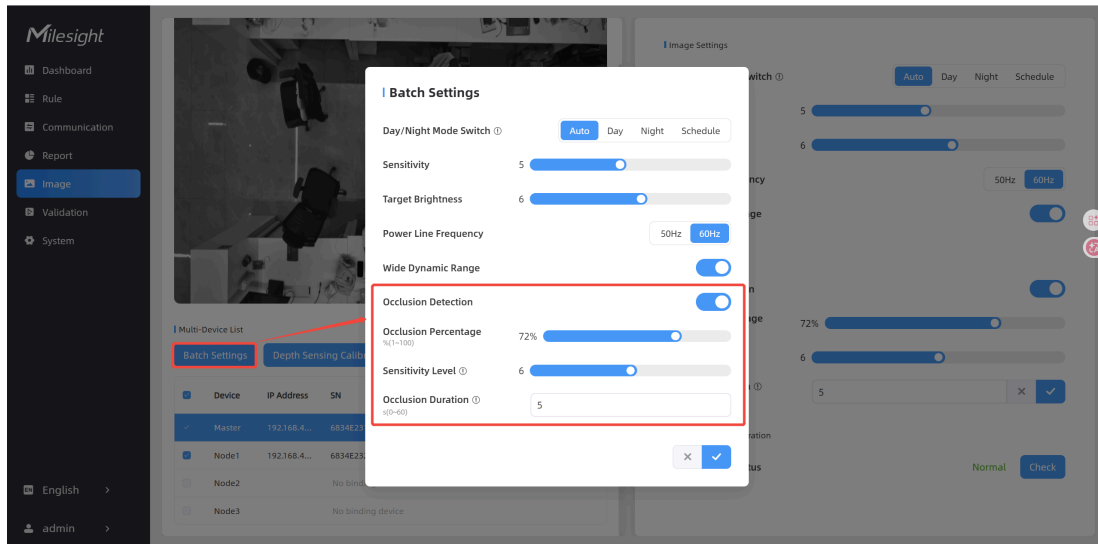

4. Click  to complete the configuration.
5. Users can also view the data through [Alarm Report](#).

Configure Depth Sensing Calibration

VS125 performance may degrade due to installation stress or physical impact, affecting depth map quality and people counting accuracy. If the depth map is displayed abnormally or the counting accuracy decreases after proper installation, the user can check and restore the device's depth sensing capability.

Prerequisite: Install the device in an environment with sufficient lighting.

Steps:

1. In the main page, click **Image** from the left navigation tree.

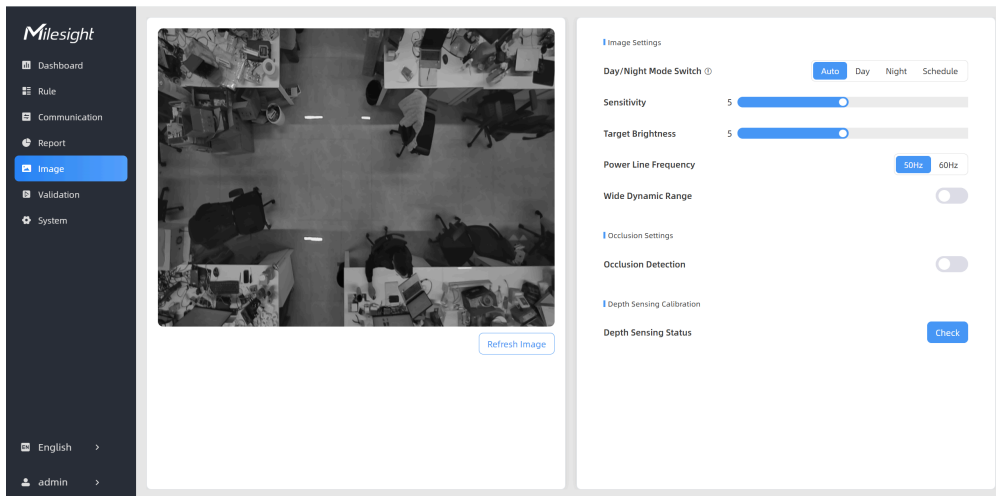

2. In the **Depth Sensing Calibration** area on the right, click **Check** to check the current depth sensing capability.



3. "Normal" indicates that depth sensing is functioning properly.



"Abnormal" means depth sensing is not working correctly. If "Abnormal" appears after two consecutive checks, click **Repair**.



If the issue persists, follow the provided instructions to place multiple stationary objects, or contact technical support.

4. (Optional) If multiple devices are stitched, you can select the devices to be detected in the depth sensing interface of the master device and perform batch detection.

Multi-Device List Refresh Image

Batch Settings Depth Sensing Calibration

<input checked="" type="checkbox"/>	Device	IP Address	SN	Device Name	Depth Sensing Status	Operation
<input checked="" type="checkbox"/>	Master	192.168.4...	6834E231...	People Count...	Normal	
<input checked="" type="checkbox"/>	Node1	192.168.4...	6834E232...	People Counter	-	
<input type="checkbox"/>	Node2		No binding device			
<input type="checkbox"/>	Node3		No binding device			

"Normal" indicates that depth sensing is functioning properly.

Depth Sensing Calibration

Depth Sensing Status

Device	IP Address	SN	Depth Sensing Status
Master	192.168.44.127	6834E23140560003	Normal
Node1	192.168.44.106	6834E23296160003	Normal

"Abnormal" means depth sensing is not working correctly. If "Abnormal" appears after two consecutive checks, click **Repair**.

Depth Sensing Calibration

Depth Sensing Status



Device	IP Address	SN	Depth Sensing Status
Master	192.168.44.127	6834E23140560003	Normal
Node1	192.168.44.106	6834E23296160003	Abnormal

Recalibration

Repair



If the issue persists, follow the provided instructions to place multiple stationary objects, or contact technical support.

Configure Video Validation

The video validation function can be used to verify people counting accuracy by comparing results against a recorded video. This section describes how to configure this function.

Steps:

1. In the main page, click **Validation** from the left navigation tree.

The screenshot displays the Milsight web interface. On the left, a dark navigation sidebar contains the following menu items: Dashboard, Rule, Communication, Report, Image, **Validation** (highlighted), and System. At the bottom of the sidebar, there are options for 'English' and 'admin'. The main content area is titled 'Recording Space' and features a progress bar showing '11.5%' usage, with '0.93GB (Used) / 7.96GB (Total)' below it. Underneath, the 'Recording Task' section includes an '+ Add' button and a table with the following data:

Task Name	Start Time	End Time	Duration min	Task Status	Size	Operation
Task 1	2025-01-04 06:46:01.356	2025-01-04 07:03:01.527	17	Manually Stopped	0.93GB	

2. In the **Recording Task** area on the right, click **+ Add**. The **Set a Task of Recording** dialog box is displayed. The device can add up to 50 tasks.

| Set a Task of Recording

Task Name

Recording Mode Record Now Setting Time

Start Time

Duration
min(1~60)

×
✓

3. Configure the following parameters as needed.

Parameters	Description
Task Name	Customize a task name.
Recording Mode	Options: Record Now or Setting Time .
Start Time	This parameter is displayed only when Recording Mode is set to Setting Time . It sets the recording start time.
Duration	Set the recording duration. Range: ≤ 60 minutes.



Note:

The configured time ranges for different tasks must not overlap.

4. Click . The task is listed in the **Recording Task** area.



Restriction:

Detection rules cannot be modified during the recording process.

5. After recording completed, click in the **Operation** area of the task. The following page is displayed.

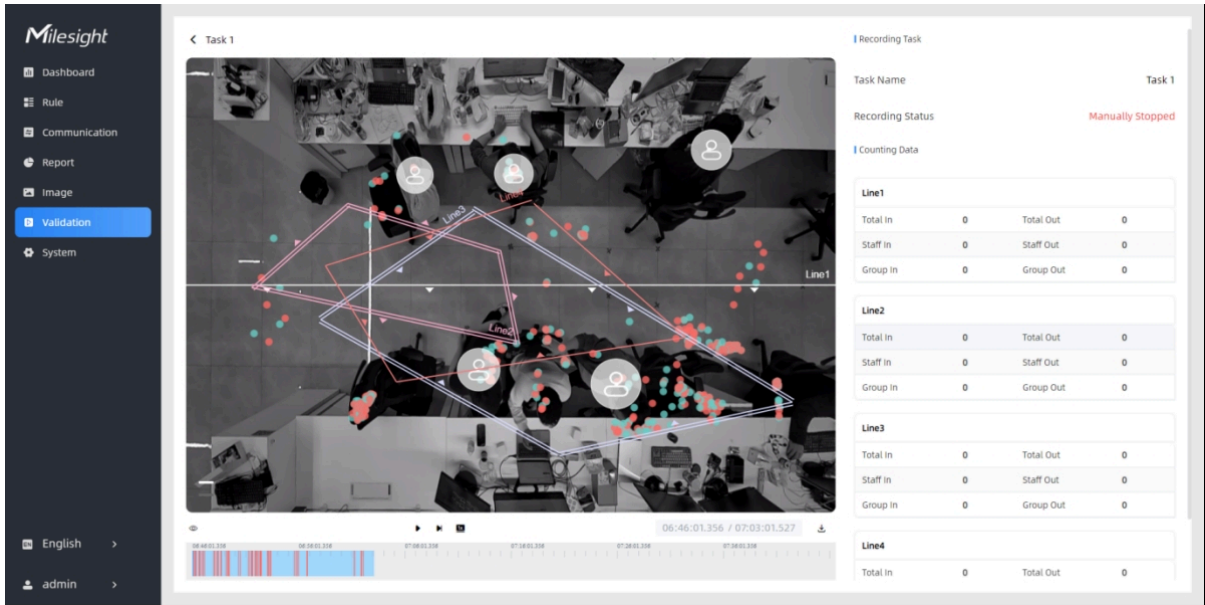

6. Click  to edit the preview layout. For details, refer to the following table.

Edit Preview Layout

Visual Configuration

- Detection Line
- U-turn Area
- Detection Region
- Obstacle Exclusion Region

AI Result

- Real-time Track Line
- Static Track Line

Other

- Track Start  / Stop  Points

Parameters	Description
Visual Configuration	Click the corresponding rules to show/hide them in the video.
AI Result	Click the corresponding lines to show/hide them in the video. - Real-time Track Line: Real-time trajectory line of the targets - Static Track Line: Historical trajectory line of the targets
Other	Click  to show/hide track points in the video.

7. Click  to play the video to verify people counting accuracy.

**Note:**

The playback progress bar in the bottom highlights video frames where data changes occur.

8. (Optional) Click  to download the video and use the dedicated [Milesight VS Player](#) for local playback.

Configure System Parameters

This section describes how to configure system parameters.

Configure Device Parameters

The device hardware and software information can be checked on the **System** page. Besides, users can customize the device name, the device ID and the site ID for multi-device management.

Steps:

1. In the main page, click **System** from the left navigation tree.

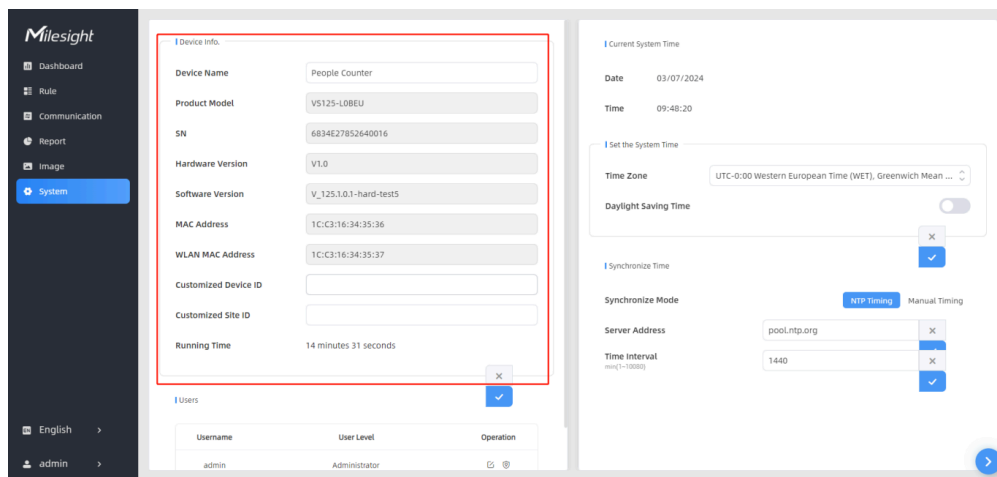

2. In the **Device Info.** area, check device information and configure the device name, the device ID and the site ID as needed.

3. Click  to save the configuration.

Configure User Parameters

This section describes how to configure user parameters.

User Roles:

- Administrator: Has full system privileges with access to all webpage settings
- Viewer: Has access only to the **Dashboard** and **Report** pages

Modify Administrator's Parameters

1. In the main page, click **System** from the left navigation tree.
2. To change the login password of the device:

- a. In the **User** area, click  in the **Operation** column. The **Users modify** dialog box is displayed.

Users modify

Username

User Level

Administrator Password

New Password

Confirm Password



At least



- 8 characters
- Must contain uppercase letters, lowercase letters, numbers, and special characters

- b. In the **Administrator Password** area, enter the login password of the device.
 - c. In the **New Password** area, enter a new password.
 - d. In the **Confirm Password** area, enter the new password again.
 - e. Click  to save the configuration.
3. To configure the security questions:

- a. Click . The **Secure Question Settings** dialog box is displayed.

Secure Question Settings Already Set

Password	<input type="text"/>
Security Question1	What is your lucky number? 
Answer1	<input type="text"/>
Security Question2	What is your favorite sport? 
Answer2	<input type="text"/>
Security Question3	What is your favorite color? 
Answer3	<input type="text"/>

- b. Enter the login password and provide answers to the three security questions.
- c. Click  to save the configuration.

**Troubleshooting:**

In case that you forget the password, you can click **Forget Password** on the login page to reset the password by answering the three security questions.

Add a Viewer

1. Click **+ Add User**. The **Add User** dialog box is displayed.

Add User

Username

User Level

Password

Confirm Password

At least

- 8 characters
- Must contain uppercase letters, lowercase letters, numbers, and special characters

2. In the **Password** area, enter a new password.

3. In the **Confirm Password** area, enter the new password again.

4. Click to save the configuration. The user is listed in the **Users** area.

Username	User Level	Operation
admin	Administrator	<input type="checkbox"/> <input type="checkbox"/>
viewer	Viewer	<input checked="" type="checkbox"/> <input checked="" type="checkbox"/>

5. (Optional) Click  to change the password of the viewer.

Users modify

Username	<input type="text" value="viewer"/>
User Level	<input type="text" value="Viewer"/>
Administrator Password	<input type="text"/>
New Password	<input type="text"/>
Confirm Password	<input type="text"/>

At least

- 8 characters
- Must contain uppercase letters, lowercase letters, numbers, and special characters



Configure Time Parameters

This section describes how to configure time parameters.



Steps:

1. In the main page, click **System** from the left navigation tree.
2. In the **Set the System Time** area, configure the following parameters as needed.

Parameters	Description
Time Zone	Select the time zone for system synchronization.
Daylight Saving Time	Enable or disable Daylight Saving Time (DST).
	Start Time: Start time of the DST time range.
	End Time: End time of the DST time range.

Parameters	Description
	DST Bias: Specifies the offset value for advancing clock time during Daylight Saving Time periods.

3. In the **Synchronize Time** area, perform the following operations as needed.
 - a. Set **Synchronize Mode** to **NTP Timing** or **Manual Timing** as needed.
 - b. Perform the following operations as needed.

If	Do
If Synchronize Mode is set to NTP Timing	<ol style="list-style-type: none"> i. In the Server Address area, enter the NTP server address and click . ii. In the Time Interval area, enter the time synchronization interval between the device and the NTP server and click .
If Synchronize Mode is set to Manual Timing	<ol style="list-style-type: none"> i. In the Setting Time area, set the device time and click . ii. In the Synchronize with your computer time area, click Synchronize to synchronize the device time with the computer system time.

Configure Remote Management Parameters

Milesight provides remote management service for this device through the [Milesight DeviceHub platform](#) and the [Milesight Development Platform](#). Successful connection requires that the device is connected to the network and the Internet connection is stable. This section describes how to configure remote management.

Steps:

1. In the main page, click **System** from the left navigation tree.
2. Click  in the lower right corner. The following page is displayed.

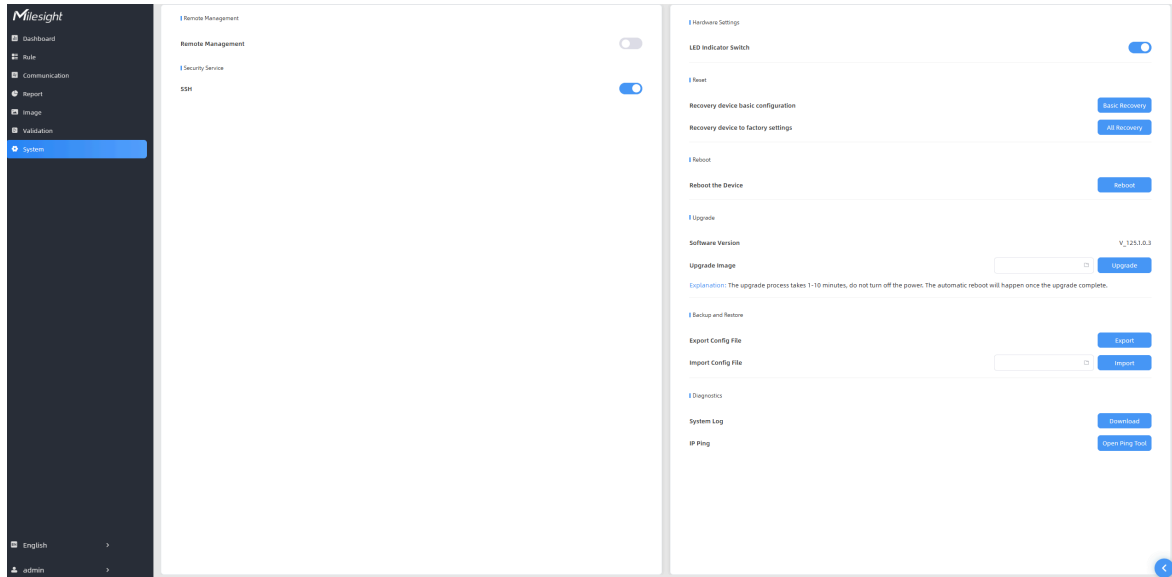

3. In the **Remote Management** area, enable **Remote Management**.

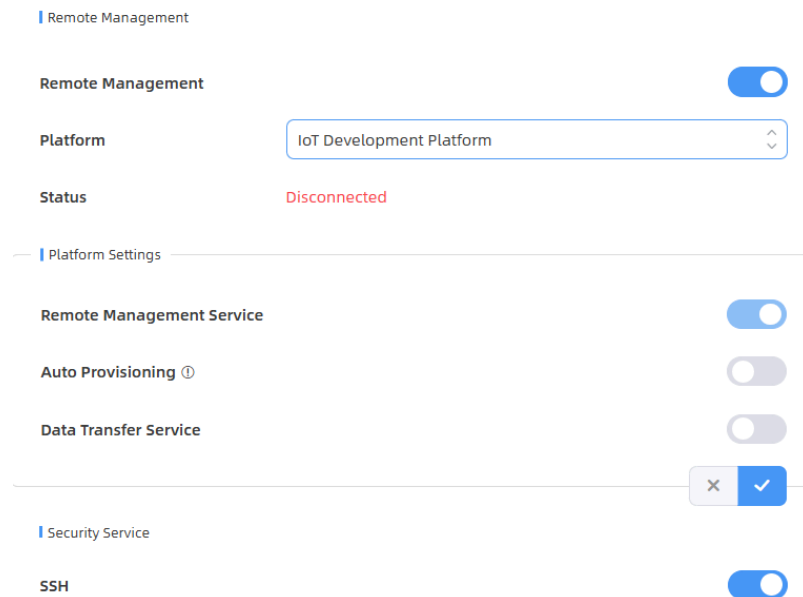

4. Set **Platform** to **DeviceHub2.0** or **IoT Development Platform** as needed. For detailed platform information, refer to [DeviceHub](#) and [Mulesight Development Platform](#) respectively.

5. Perform the following operations as needed.

If	Do
If Platform is set to Device-Hub2.0 (PoE Version Only)	<ol style="list-style-type: none"> a. In the Server Address area, enter the IP address or the host name for the DeviceHub 2.0 management server. b. Enable Synchronize Device Name to synchronize the device name with Devicehub 2.0. c. Enable Synchronize Customized ID to synchronize the device ID and site ID with Devicehub 2.0. d. Click Connect.
If Platform is set to IoT Development Platform	<ol style="list-style-type: none"> a. Enable Remote Management Service to modify device configuration through the Milesight Development platform. b. Enable Auto Provisioning. Then the device obtains preconfiguration files from the IoT Development Platform server for the first time or after reset upon Internet connection. c. Configure data transfer parameters to report people counting data to the Milesight Development platform at the specified interval. <ol style="list-style-type: none"> i. Enable Data Transfer Service. Periodic Report is enabled automatically. ii. Set Periodic Report Scheme to On the Dot or From Now On as needed. iii. Set Period. iv. Enable Trigger Report as needed.

6. Click  to save the configuration.

7. In the **Security Service** area, enable **SSH** to enable SSH access. The SSH port is fixed as 22.

Configure System Maintenance Parameters

This section describes how to configure system maintenance parameters.

Steps:

1. In the main page, click **System** from the left navigation tree.
2. Click  in the lower right corner. The following page is displayed.

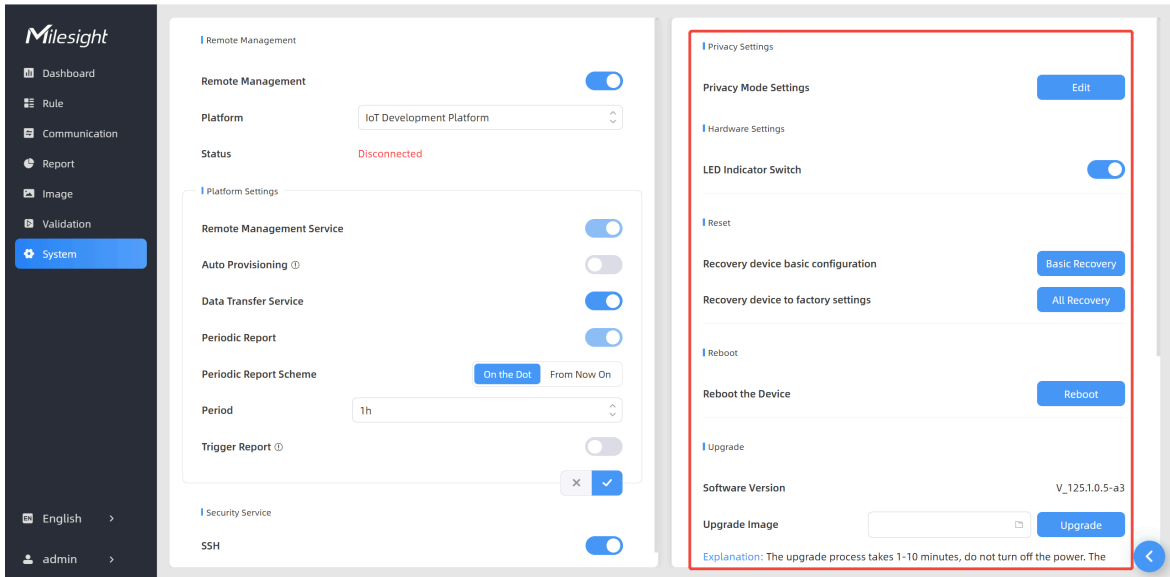

3. In the page on the right, configure the following parameters as needed.

Parameters	Description
Privacy Settings	Privacy Mode Settings: Click Edit to switch the preview mode when they want to change the Dashboard display. For parameter definitions, please refer to First Login .
Hardware Settings	LED Indicator Switch: Enable or disable the LED indicator when the device is in normal operation.
Reset	Recovery device basic configuration: Click Basic Recovery to reset the device while keeping the IP settings and user information.
	<p>Recovery device to factory settings:</p> <ol style="list-style-type: none"> Click All Recovery to reset the device to default factory settings. The Tips dialog box is displayed. <div style="border: 1px solid #ccc; padding: 5px; margin: 5px 0;"> <p>Tips</p> <p>Administrator Password <input type="text"/></p> <p style="text-align: right;"><input type="button" value="x"/> <input type="button" value="✓"/></p> </div> <ol style="list-style-type: none"> Enter the login password of the device.
Reboot	Reboot the Device: Click Reboot to restart the device immediately.
Upgrade	Upgrade Image: Click <input type="file"/> to upload the upgrading file and click the Upgrade to upgrade the device. The upgrade process takes 1 to 10 minutes.

Parameters	Description
	<p>The power must not be turned off during the process. The device is automatically rebooted once the upgrade is completed.</p> <div data-bbox="542 380 1414 600" style="background-color: #fff9c4; padding: 10px; border: 1px solid #ccc;"> <p>! Important: Please confirm carefully before upgrading, as once upgraded to version 1.0.5 or above, you will not be able to revert to a lower version.</p> </div>
Backup and Restore	Export Config File: Click Export to export the configuration file.
	Import Config File: Click  to upload a configuration file and click Import to import the configuration file.
Diagnostics	System Log: Click Download to download log files for troubleshooting.
	Logging Level Settings: System logs do not include debug information by default. To obtain more detailed debug logs for troubleshooting, please switch to Include Debug .
	<p>IP Ping:</p> <ol style="list-style-type: none"> Click Open Ping Tool. The Ping Tool dialog box is displayed. In the Host area, enter an IP address or a URL to test network connection. Click Ping. <div data-bbox="618 1283 1216 1745" style="border: 1px solid #ccc; padding: 10px; margin-top: 10px;"> <p>Ping Tool</p> <p>Host <input type="text" value="www.google.com"/> Ping Stop</p> <pre style="font-family: monospace; font-size: 0.9em;">PING www.google.com (142.250.196.228): 56 data bytes 64 bytes from 142.250.196.228: seq=0 ttl=113 time=31.403 ms 64 bytes from 142.250.196.228: seq=1 ttl=113 time=30.818 ms 64 bytes from 142.250.196.228: seq=2 ttl=113 time=34.176 ms 64 bytes from 142.250.196.228: seq=3 ttl=113 time=30.537 ms --- www.google.com ping statistics --- 4 packets transmitted, 4 packets received, 0% packet loss round-trip min/avg/max = 30.537/31.733/34.176 ms</pre> <p style="text-align: right;">×</p> </div>

Chapter 5. Uplink Data and Downlink Commands

This chapter describes the uplink data packets and downlink commands supported by the device.

Uplink Data

The device can transmit people counting data in JSON format to a HTTP URL or an MQTT broker. For configuration details, refer to [Configure Recipient Parameters](#). This section provides uplink data examples for both real-time and periodic reporting.

Uplink Data Examples for Real-Time Reporting

If the report strategy is set to **Trigger Report** (real-time reporting is enabled), the device reports the uplink data upon data change. This section provides uplink data examples for real-time reporting.

Data Example for Line Crossing People Counting

```
{
  "device_info":
  {
    "cus_device_id": "123456",
    "cus_site_id": "789123",
    "device_mac": "24:E1:24:FA:0C:6C", //PoE version only
    "device_name": "People Counter",
    "device_sn": "6384E16179950009",
    "firmware_version": "V_125.1.0.1",
    "hardware_version": "V1.0",
    "ip_address": "192.168.60.183",
    "running_time": 58,
    "wlan_mac": "24:E1:24:54:23:0A"
  },
  "network_info": //Cellular version only
  {
    "network_status": "1", //1 is connected, 0 is disconnected
    "iccid": "89860117838009934120",
    "imei": "860425047368939",
    "cell_id": "340db80",
    "lac": "5299"
  },
}
```

```
"line_trigger_data":  
[  
{  
  "children": {  
    "female_in": 8,  
    "female_out": 2,  
    "in": 14,  
    "male_in": 8,  
    "male_out": 2,  
    "out": 6  
  },  
  "group": {  
    "in": 0,  
    "out": 0  
  },  
  "staff": {  
    "female_in": 0,  
    "female_out": 0,  
    "in": 0,  
    "male_in": 0,  
    "male_out": 0,  
    "out": 0  
  },  
  "total": {  
    "female_in": 20,  
    "female_out": 22,  
    "in": 27,  
    "male_in": 20,  
    "male_out": 22,  
    "out": 27  
  },  
  "line": 1,  
  "line_name": "Line11111111111111111111111111111111",  
  "line_uuid": "9a0440de-3188-4f6d-b886-bb20c97bd26b"  
},  
{  
  "children": {
```

```
"female_in": 8,  
"female_out": 2,  
"in": 14,  
"male_in": 8,  
"male_out": 2,  
"out": 6  
},  
"group": {  
  "in": 0,  
  "out": 0  
},  
"staff": {  
  "female_in": 0,  
  "female_out": 0,  
  "in": 0,  
  "male_in": 0,  
  "male_out": 0,  
  "out": 0  
},  
"total": {  
  "female_in": 20,  
  "female_out": 22,  
  "in": 27,  
  "male_in": 20,  
  "male_out": 22,  
  "out": 27  
},  
"line": 3,  
"line_name": "Line33333333333333333333333333333333",  
"line_uuid": "82ffe54d-0191-484b-a2fc-495628a8f2a1"  
}  
],  
"time_info":  
{  
  "dst_status": false,  
  "enable_dst": true,  
  "time": "2024-05-30T20:11:32+08:00",
```

```

"time_zone": "UTC+8:00 China Standard Time (CT/CST)"
}
}

```

Data Example for Region People Counting

```

{
"device_info":
{
"cus_device_id": "123456",
"cus_site_id": "789123",
"device_mac": "24:E1:24:FA:0C:6C", //PoE version only
"device_name": "People Counter",
"device_sn": "6384E16179950009",
"firmware_version": "V_125.1.0.1",
"hardware_version": "V1.0",
"ip_address": "192.168.60.183",
"running_time": 105,
"wlan_mac": 24:E1:24:54:23:0A
},
"network_info": //Cellular version only
{
"network_status": "1", //1 is connected, 0 is disconnected
"iccid": "89860117838009934120",
"imei": "860425047368939",
"cell_id": "340db80",
"lac": "5299"
},
"region_trigger_data":
{
"region_count_data":
[
{
"total": {
"current_female": 0,
"current_male": 1,

```

```

    "current_total": 2
  },
  "children": {
    "current_female": 0,
    "current_male": 1,
    "current_total": 2
  },
  "staff": {
    "current_female": 0,
    "current_male": 1,
    "current_total": 2
  },
  "region": 1,
  "region_name": "Region1",
  "region_uuid": "bd1e6ce2-e113-4ce4-a9b6-0633f7083cac"
}
]
},
"time_info":
{
  "dst_status": false,
  "enable_dst": true,
  "time": "2024-05-30T20:12:20+08:00",
  "time_zone": "UTC+8:00 China Standard Time (CT/CST)"
}
}

```

Data Example for Dwell Time Detection

```

{
  "device_info":
  {
    "cus_device_id": "123456",
    "cus_site_id": "789123",
    "device_mac": "24:E1:24:FA:0C:6C", //PoE version only
    "device_name": "People Counter",
    "device_sn": "6384E16179950009",
    "firmware_version": "V_125.1.0.1",

```

```

"hardware_version": "V1.0",
"ip_address": "192.168.60.183",
"running_time": 106,
"wlan_mac": "24:E1:24:54:23:0A"
},
"network_info": //Cellular version only
{
  "network_status": "1", //1 is connected, 0 is disconnected
  "iccid": "89860117838009934120",
  "imei": "860425047368939",
  "cell_id": "340db80",
  "lac": "5299"
},
"region_trigger_data":
{
  "dwell_time_data":
[
{
  "children": false,
  "duration": 96799,
  "dwell_end_time": "2024-05-30T20:12:20+08:00",
  "dwell_start_time": "2024-05-30T20:10:43+08:00",
  "people_id": 5,
  "region": 1,
  "region_name": "Region1",
  "region_uuid": "bd1e6ce2-e113-4ce4-a9b6-0633f7083cac",
  "gender": "male",
  "staff": true
}
]
},
"time_info":
{
  "dst_status": false,
  "enable_dst": true,
  "time": "2024-05-30T20:12:20+08:00",

```

```

"time_zone": "UTC+8:00 China Standard Time (CT/CST)"
}
}

```

Data Example in Case that an Effective Viewer Track Disappears

```

{
  "device_info": {
    "cus_device_id": "123456",
    "cus_site_id": "789123",
    "device_mac": "24:E1:24:FA:0C:6C",
    "device_name": "People Counter11",
    "device_sn": "6384E16179950009",
    "firmware_version": "V_125.1.0.1-chenjs-20240530a",
    "hardware_version": "V1.0",
    "ip_address": "192.168.60.183",
    "running_time": 58
  },
  "network_info": {
    "network_status": "1",
    "iccid": "89860117838009934120",
    "imei": "860425047368939",
    "cell_id": "340db80",
    "lac": "5299"
  },
  "attention_region_trigger_data": {
    "region_attention_time_data": [
      {
        "region": 1,
        "region_uuid": "c2cff789-8311-4a73-8ff3-9348cf4fa0d9",
        "children": false,
        "attention_time_ms": 96799,
        "people_id": 5,
        "gender": "male",
        "staff": true
      },
      {
        "region": 2,

```

```

"region_uuid": "c2cff789-8311-4a73-8ff3-9348cf4fa0d9",
"children": false,
"attention_time_ms": 96799,
"people_id": 5,
"gender": "male",
"staff": true
}
],
},
"time_info": {
"dst_status": false,
"enable_dst": true,
"time": "2024-05-30T20:11:32+08:00",
"time_zone": "UTC+8:00 China Standard Time (CT/CST)"
}
}

```

Data Example for Digital Input

```

{
"device_info": {
"cpu": {
"cpu_temperature": 50,
"cpu_usage": 62
},
"device_mac": "24:E1:24:FA:77:49",
"device_name": "66",
"device_sn": "6834E23009150005",
"device_tilt_pitch_roll": {
"pitch": 161.8,
"roll": 147.6
},
"firmware_version": "V_125.1.0.5-a2",
"hardware_version": "V1.1",
"ip_address": "192.168.49.152",
"ram": {
"memory_usage": 52.97,
"total_memory_mb": 480.62,

```

```

    "used_memory_mb": 254.56
  },
  "running_time": 496781,
  "storage": {
    "storage_usage": 26.83,
    "total_space_gb": 11.71,
    "used_space_gb": 3.14
  },
  "wlan_mac": "24:E1:24:FA:77:4A"
},
"network_info": {
  "network_status": "1",
  "iccid": "89860117838009934120",
  "imei": "860425047368939",
  "cell_id": "340db80",
  "lac": "5299"
},
"di_trigger_data": {
  "di_trigger_count": 69390,
  "di_trigger_event_name": "test"
},
"isRetransmission": false,
"time_info": {
  "dst_status": false,
  "enable_dst": true,
  "time": "2024-05-30T20:11:32+08:00",
  "time_zone": "UTC+8:00 China Standard Time (CT/CST)"
}
}

```

Uplink Data Example for Periodic Reporting

If the report strategy is set to **Periodic Report**, the device reports the uplink data upon data change at the configured interval. This section provides a uplink data example for periodic reporting.

```

{
  "device_info": {
    "cus_device_id": "123456",

```



```

    "out_counted": 0
  },
  "group" {
    "in_counted": 0,
    "out_counted": 0
  }

},
"region_data": {
  "dwell_time_data": {
    "avg_dwell_time": 308367,
    "children_avg_dwell_time": 0,
    "children_max_dwell_time": 0,
    "female_avg_dwell_time": 0,
    "female_max_dwell_time": 519934,
    "male_avg_dwell_time": 0,
    "male_max_dwell_time": 96799,
    "max_dwell_time": 519934,
    "staff_max_dwell_time": 1522,
    "staff_avg_dwell_time": 1522,
    "region": 1,
    "region_name": "Region1",
    "region_uuid": "bd1e6ce2-e113-4ce4-a9b6-0633f7083cac"
  }
},
"region_count_data": {
  "total": {
    "current_female": 0,
    "current_male": 1,
    "current_total": 2
  },
  "children": {
    "current_female": 0,
    "current_male": 1,
    "current_total": 2
  },
  "staff": {

```

```

    "current_female": 0,
    "current_male": 1,
    "current_total": 2
  },
  "region": 1,
  "region_name": "Region1",
  "region_uuid": "bd1e6ce2-e113-4ce4-a9b6-0633f7083cac"
}]
},
"attention_region_total_data": {
  "region_effective_audience_data": [
    {
      "region": 1,
      "region_uuid": "c2cff789-8311-4a73-8ff3-9348cf4fa0d9",
      "total": {
        "effective_audience": 1,//Including staffs and children
        "male_effective_audience": 1,//Including male staffs and boys
        "female_effective_audience": 1,////Including female staffs and girls
      },
      "children": {
        "effective_audience": 1,
        "male_effective_audience": 1,
        "female_effective_audience": 1
      },
      "staff": {
        "effective_audience": 1,
        "male_effective_audience": 1,
        "female_effective_audience": 1
      }
    }
  ]
},
"region_avg_attention_time_data": //Excluding staffs and children
{
  "region": 1,
  "region_uuid": "c2cff789-8311-4a73-8ff3-9348cf4fa0d9",
  "avg_time_s": 10,
  "children_avg_time_s": 10,

```

```

    "staff_avg_time_s": 10,
    "male_avg_time_s": 10,
    "female_avg_time_s": 10
  },
  {
    "region": 2,
    "region_uuid": "c2cff789-8311-4a73-8ff3-9348cf4fa0d8",
    "avg_time_s": 10,
    "children_avg_time_s": 10,
    "staff_avg_time_s": 10,

    "male_avg_time_s": 10,
    "female_avg_time_s": 10
  }
]
},
"di_period_data": {
  "di_trigger_count": 119,
  "di_trigger_event_name": "test"
},
"di_total_data": {
  "di_trigger_count": 69390,
  "di_trigger_event_name": "test"
},
"time_info": {
  "dst_status": false,
  "enable_dst": true,
  "end_time": "2024-05-30T20:21:49+08:00",
  "start_time": "2024-05-30T20:20:49+08:00",
  "time_zone": "UTC+8:00 China Standard Time (CT/CST)"
}
}

```

Uplink Data Examples for Alarm Reporting

When the device encounters an abnormal situation, it will report an alarm. This section provides uplink data examples for alarm reporting.

Data Example for Device Abnormal Tilt

```
{
  "device_abnormal_tilt_alarm": [
    {
      "alarm_status": "alarm",
      "device_sn": "6834E23009150005"
    }
  ],
  "device_info": {
    "cpu": {
      "cpu_temperature": 60,
      "cpu_usage": 54
    },
    "device_mac": "24:E1:24:FA:77:49",
    "device_name": "66",
    "device_sn": "6834E23009150005",
    "device_tilt_pitch_roll": {
      "pitch": 105,
      "roll": -153
    },
    "firmware_version": "V_125.1.0.5-a1",
    "hardware_version": "V1.1",
    "ip_address": "192.168.49.152",
    "ram": {
      "memory_usage": 36.01,
      "total_memory_mb": 480.62,
      "used_memory_mb": 173.05
    },
    "running_time": 7362,
    "storage": {
      "storage_usage": 0.04,
      "total_space_gb": 11.71,
      "used_space_gb": 0
    },
    "wlan_mac": "24:E1:24:FA:77:4A"
  },
  "isRetransmission": false,
```

```

"time_info": {
  "dst_status": false,
  "enable_dst": false,
  "time": "2026-01-13T19:49:58+08:00",
  "time_zone": "UTC+8:00 China Standard Time (CT/CST)"
}
}

```

Data Example for Device Occlusion

```

{
  "device_info": {
    "cpu": {
      "cpu_temperature": 60,
      "cpu_usage": 76
    },
    "device_mac": "24:E1:24:FA:77:49",
    "device_name": "66",
    "device_sn": "6834E23009150005",
    "device_tilt_pitch_roll": {
      "pitch": 129.5,
      "roll": 142.1
    },
    "firmware_version": "V_125.1.0.5-a2",
    "hardware_version": "V1.1",
    "ip_address": "192.168.49.152",
    "ram": {
      "memory_usage": 36.89,
      "total_memory_mb": 480.62,
      "used_memory_mb": 177.28
    },
    "running_time": 2682,
    "storage": {
      "storage_usage": 21.59,
      "total_space_gb": 11.71,
      "used_space_gb": 2.53
    },
    "wlan_mac": "24:E1:24:FA:77:4A"
  }
}

```

```

},
"device_occlusion_alarm": [
  {
    "alarm_status": "alarm",
    "device_sn": "6834E23009150005"
  }
],
"isRetransmission": false,
"time_info": {
  "dst_status": false,
  "enable_dst": false,
  "time": "2026-01-27T16:09:03+08:00",
  "time_zone": "UTC+8:00 China Standard Time (CT/CST)"
}
}

```

MQTT API Commands

This section provides examples of the MQTT API commands supported by the device. For how to configure MQTT API parameters, refer to [Configure MQTT API Parameters \(Cellular Version Only\)](#).

Search Report Commands

Request example:

```

{
  "dst": "all",
  "type": 0,
  "command": "/api/v1/system/searchReport",
  "msgId": "1",
  "requestData": {
    "event": 0,
    "startTime": "2025-01-22T08:00:00.000",
    "endTime": "2025-01-23T08:00:00.000",
    "lineParam": {
      "lineId": 0,
      "timeUnit": 0,
      "mode": 0
    }
  },
}

```

```

"regionCount":{
  "regionId":0
},
"dwelDetect":{
  "regionId":0,
  "timeMin":10,
  "timeBinWidth":10,
  "numOfBins":10
},
"heatMap":{
  "type":0
},
"uuid":"1d4f62b5-37f0-4bda-80f8-a5625613fc6e"
}
}

```

For request example parameter descriptions, refer to the following table.

Parameter	Type	Description
dst	string	all : Send to all recipients that subscribe the MQTT API topic. SN : Send to a certain recipient.
type	number	0 : Request, 1 : Response.
msgId	number	Request identifier.
requestData	object	
event	number	0 : Line crossing counting 1 : Region people counting 2 : Dwell time detection 3 : Heat map 4 : History Point
startTime		

Parameter	Type	Description
endTime		
lineParam		
regionCount		
dwelIDetct		
heatMap		
uuid	string	Random unique ID defined by the user

Response example: Success

```
{
  "code":0,
  "message":"ok",
  "msgId":"1",
  "src":"6834E16184430017",
  "transmitTime":2,
  "type":1
}
```

For response example parameter descriptions, refer to the following table.

Parameter	Type	Description
code	integer	
message	string	
msgId	number	Response identifier
src	string	Response SN
type	number	0 : Request, 1 : Response

Get Report Result Commands

Request example:

```
{
  "dst": "all",
  "type":0,
}
```

```

"command":"/api/v1/system/getReportResult",
"msgId":"1",
"requestData":{
  "uuid":"1d4f62b5-37f0-4bda-80f8-a5625613fc6e",
  "event":0
}
}

```

For request example parameter descriptions, refer to the following table.

Parameter	Type	Description
dst	string	all : Send to all recipients that subscribe the MQTT API topic. SN : Send to a certain recipient.
type	number	0 : request, 1 : response.
msgId	number	Request identifier.
requestData	object	
uuid	string	Random unique ID defined by the user.
event	number	0 : Line crossing counting. 1 : Region people counting. 2 : Dwell time detection. 3 : Heat map.

Response example:

```

{
  "code": 0,
  "data": {
    "event": 0,
    "isReady": true,
    "line": [
      {
        "children": {

```

```
"femaleIn": 0,  
"femaleOut": 1,  
"in": 6,  
"maleIn": 6,  
"maleOut": 0,  
"out": 1  
},  
"group": {  
  "in": 9,  
  "out": 3  
},  
"staff": {  
  "femaleIn": 0,  
  "femaleOut": 0,  
  "in": 0,  
  "maleIn": 0,  
  "maleOut": 0,  
  "out": 0  
},  
"time": "2024-08-15T09:00:00.000",  
"total": {  
  "femaleIn": 0,  
  "femaleOut": 1,  
  "in": 9,  
  "maleIn": 9,  
  "maleOut": 2,  
  "out": 3  
}  
}  
]  
},  
"message": "ok",  
"transmitTime": 1  
}
```

For response example parameter descriptions, refer to the following table.

Parameter	Type	Description
code	integer	
data	object []	Return data
event	number	0: Line crossing counting 1: Region people counting 2: Dwell time detection 3: Heat map
isReady	boolean	
line,region	object	Including children, staff, group, total
children, staff,group ,d-well , total	object	Including in, out, femaleIn, femaleOut, maleIn, maleOut
heatmap	object	
height	number	Height of the heatmap data grid
width	number	Width of the heatmap data grid
max	number	Maximum value of heat map
min	number	Minimum value of heat map
values	object[]	
X	number	
Y	number	
value	number	
historyPoints		
values	object[]	Trajectory point types: 0: Start trajectory point 1: Stop trajectory point

Parameter	Type	Description
X	number	
Y	number	
message	string	Return information
transmitTime	number	Processing time

Search Log Commands

Request example:

```
{
  "dst": "all",
  "type": 0,
  "command": "/api/v1/system/searchLog",
  "msgId": 12345678,
  "requestData": {
    "startTime": "0",
    "endTime": "1800211081920",
    "logType": 0,
    "admin": true
  }
}
```

For request example parameter descriptions, refer to the following table.

Parameter	Type	Description
dst	string	all : Send to all recipients that subscribe the MQTT API topic. SN : Send to a certain recipient.
type	number	0 : Request, 1 : Response.
msgId	number	Request identifier.
requestData	object	
startTime	string	Start timestamp. Unit: ms.

Parameter	Type	Description
endTime	string	End timestamp. Unit: ms.
logType	number	0 : Starting up log.
admin	boolean	true : Display response parameter rebootCode . false : Hide response parameter rebootCode .

Response example:

```
{
  "code": 0,
  "data": {
    "log": [
      {
        "PowerOnTime": "2024-07-22T09:34:27+08:00",
        "ShutdownTime": "2024-07-22T09:41:59+08:00",
        "rebootCode": 1,
        "rebootMessage": "normal",
        "runningTime": 451
      },
      {
        "PowerOnTime": "2024-07-22T09:42:05+08:00",
        "ShutdownTime": "2024-07-22T09:54:47+08:00",
        "rebootCode": 3,
        "rebootMessage": "upgrade success",
        "runningTime": 761
      }
    ],
    "recordCount": 5
  },
  "message": "ok",
  "transmitTime": 3
}
```

For response example parameter descriptions, refer to the following table.

Parameter	Type	Description
code	integer	
data	object	
log	object[]	Item type: object
PowerOnTime	string	Boot time
ShutdownTime	string	Power outage time
rebootCode	string	<p>-1: Running</p> <p>0: Unknown reason reboot</p> <p>1: Manual reboot</p> <p>2: Network modification reboot</p> <p>3: Web upgrade reboot</p> <p>4: Software reset reboot</p> <p>5: Hardware reset reboot</p> <p>6: Configuration import reboot</p> <p>7: Remote management configuration import</p> <p>8: Remote management upgrade</p> <p>9: Upgrade failure reboot</p> <p>10: Multicast network configuration modification reboot</p> <p>11: mssserver crash</p> <p>12: avserver crash</p> <p>13: lighttpd crash</p> <p>14: Multi-device stitching mode change</p> <p>15: Multiple 4G dial-up failures</p>
runningTime	integer	

Parameter	Type	Description
runningTime	string	
recordCount	integer	Number of restarts. Maximum display 1000.
message	string	
transmitTime	number	Processing time

Chapter 6. Services

Milesight provides customers with timely and comprehensive technical support services. End-users can contact your local dealer to obtain technical support. Distributors and resellers can contact directly with Milesight for technical support.

Technical Support Mailbox: iot.support@milesight.com

Online Support Portal: <https://support.milesight-iot.com>

Resource Download Center: <https://www.milesight.com/iot/resources/download-center/>

MILESIGHT CHINA

TEL: +86-592-5085280

FAX: +86-592-5023065

Add: Building C09, Software Park Phase III, Xiamen 361024, Fujian, China