

Mclimate CO2 Display LoRaWAN®

User manual

Scan the QR Code
to access MClimate
CO2 Display LoRaWAN®
extended documentation

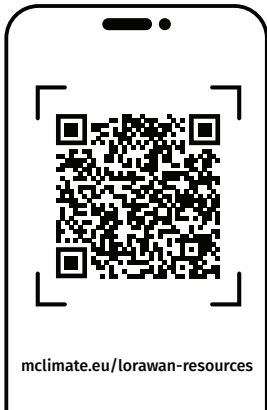

Bulgarian

За да разберете как се инсталира MClimate CO2 Display LoRaWAN®, сканирайте QR кода или посетете линка до него.

Czech

Chcete-li zjistit, jak nainstalovat MClimate CO2 Display LoRaWAN®, prohlédněte si kód QR nebo navštivte odkaz vedle něj.

Finnish

Tutustu MClimate CO2 Display LoRaWAN®-laitteen asentamiseen, skanna QR-koodi tai vierailla sen vieressä olevassa linkissä.

Swedish

För att ta reda på hur du installerar MClimate CO2 Display LoRaWAN®, skanna QR-koden eller besök länken bredvid den.

Spanish

Para saber cómo instalar MClimate CO2 Display LoRaWAN®, escanee el código QR o visite el enlace al lado.

Dutch

Om te weten te komen hoe u MClimate CO2 Display LoRaWAN® installeert, scan de QR-code of bezoek de link ernaast.

Polish

Aby dowiedzieć się, jak zainstalować MClimate CO2 Display LoRaWAN®, zeskanuj kod QR lub odwiedź link obok niego.

Italian

Per installare MClimate CO2 Display LoRaWAN® scannerizzare il codice QR oppure aprire il link al suo lato.

German

Um herauszufinden, wie man MClimate CO2 Display LoRaWAN® installiert, scannen Sie den QR-Code oder besuchen Sie den Link daneben.

French

Pour savoir comment installer MClimate CO2 Display LoRaWAN®, scannez le code QR ou visitez le lien à côté de celui-ci.



Need some help?

For more product information and issues related to it, visit:
mclimate.eu/lorawan-resources

or write us to:
lorawan-support@mclimate.eu



00359 800 3 1010
Monday-Friday 09:00 - 18:00



Sofia, Bulgaria
Sofia Tech Park, Labs Building, 111J Tsarigradsko Shose

Table of content

01	What is in the box?	2
02	Technical details, Safety instructions, Legal Notices & Compatibility	3
03	Device Parts, Mechanical dimensions	4
04	Display's content	5
05	Buttons	6
06	Behavior	7
07	Commissioning	8
08	Placement guidelines	9
09	Installation	10

What's inside the box?

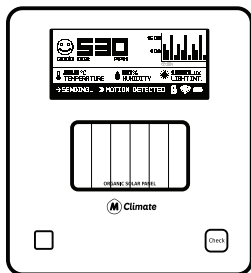

MClimate CO2 Display LoRaWAN®

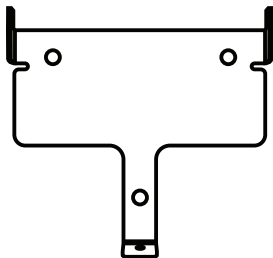

Wall mounting plate



Secure bolt

Technical specifications

Description: MClimate CO2 Display LoRaWAN is a stand-alone CO2 sensor powered entirely by solar energy using an organic solar panel. The device features a 2.9" e-ink screen, sensor for movement (PIR), temperature and humidity sensor, LUX sensor and NDIR CO2 sensor. The user can see the current levels of CO2 as well as historical trend. The device sends an uplink when it detects movement as well as periodically. The data from the CO2 Display can be used in any LoRaWAN® compatible system, incl. Building Management Systems to control demand-based ventilation. Sensor information can be exposed as datapoints in Modbus, BACnet and KNX systems through the use of a special gateway.

Created by MClimate™

SKU: MC-LW-CO2-E-INK-01

Dimensions: 105mm X 115mm X 23mm

Weight: 192gr

Materials: ABS/PC, stainless steel

Frequency range: 863-870MHz

Power supply: Solar-powered Lithium-ion capacitor (LIC) AND/OR 4xAA 1.5VDC batteries AND/OR USB-C

Sensors: CO2 (NDIR), Temperature, Humidity, PIR, LUX

Working temperature: 0°C to +50°C

Environmental conditions, in which the device is intended to operate:

- Indoor use only;
- for altitude up to 2000m;
- for an ambient temperature: 0°C to +50°C;
- for maximum relative humidity of 80% for temperature up to 31°C, decreasing linearly to 25% relative humidity at temperature 50°C;
- for an environment with a degree of contamination 2 (PD2).

Storage and transportation conditions:

- for an ambient temperature: -40°C to +85°C;
- for relative humidity 5% to 90% without condensation

Manufacturer

MClimate Jsc

1784 Sofia 31, Sofia Tech Park, Labs Building, 111J Tsarigradsko Shose

Compliance with the WEEE Directive

The appliance marked with this symbol should not be disposed of with other household waste. It must be handed over to the relevant collection point for the recycling of electrical and electronic equipment.

Safety Instructions

Please read the safety instructions before installing the device! Failure to follow the recommended instructions in this manual may be dangerous or in violation of the law. The manufacturer MClimate Jsc., is not responsible for any loss or damage caused by failure to follow the instructions in the operating manual.

Legal Notices

All information, including but not limited to, features, functionality, and / or other product specifications are subject to change without notice. MClimate retains all rights to review or update its products, software or documentation without being required to notify any natural or legal person.

The MClimate and MClimate logo are trademarks of MClimate Jsc. All other brands and product names mentioned herein are trademarks of their respective owners.

EU Declaration of Conformity

This device complies with the essential requirements and other applicable provisions of the following EU directives:

2014/53/EC

EN 50491-3:2009

EEU 300 220-1 V3.1.1:2017

EEU 300 220-2 V3.1.1:2017

EN 60950-1:2006+A11:2009 +A1:2010+A12:2011+ A2:2013 + AC:2015

EN 301 489-1 V2.1.1:2017

Compatibility

In order to operate MClimate CO2 Display LoRaWAN®, you will need:
LoRaWAN® network



Device parts

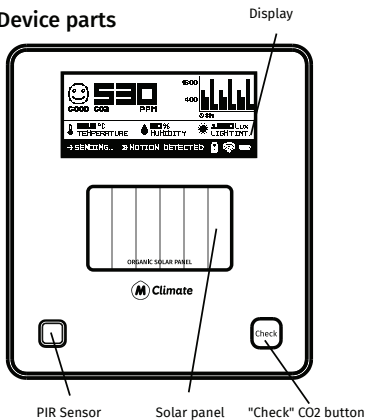

Assembled MClimate CO2 Display LoRaWAN®, top view

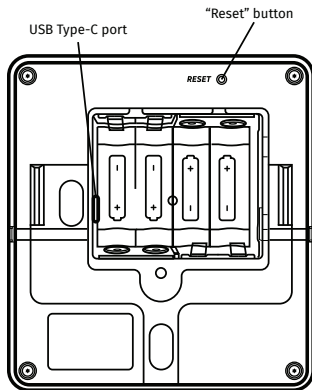

Disassembled MClimate CO2 Display LoRaWAN®, back view

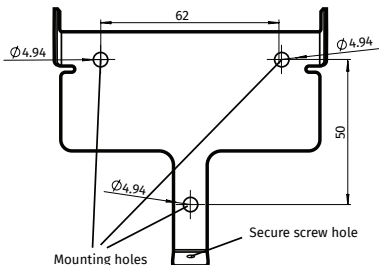

Wall mounting plate, top view

Display's content

The image below has all visible elements of the display activated.



The 2.9" e-ink display supports fast partial refresh. Full refresh is performed every 12 hours (period can be adjusted via a downlink) to avoid the e-ink phenomena "image sticking" and steer clear of permanent damage to the display.

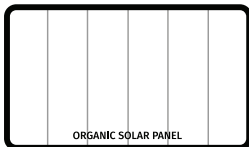
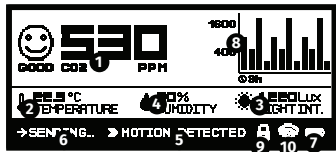

#	Description
1	Current CO2 reading
2	Sensor temperature
3	LUX reading
4	Humidity reading
5	Shown when movement is detected by the PIR
6	Shows when the sensor is transmitting an uplink
7	Power source indicator - solar, battery, USB
8	3-hour history of CO2 readings.
9	Child lock icon - indicates that the device is locked.
10	Spreading factor indicator SF7 & SF8 SF9 SF10, SF11, SF12

Buttons

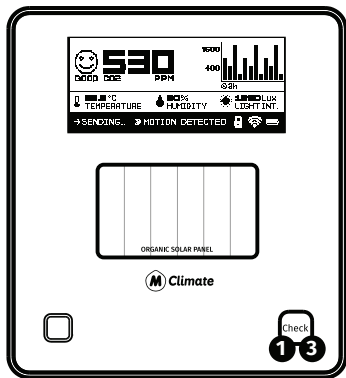

Assembled MClimate CO2 Display
LoRaWAN®, top view

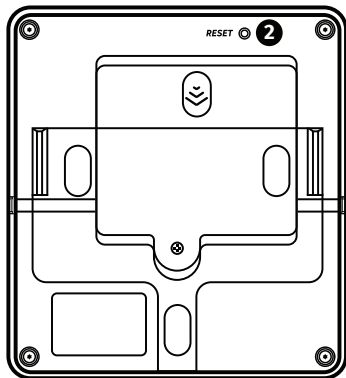

Assembled MClimate CO2 Display
LoRaWAN®, bottom view

#	Button	Function
1	Check	Check current readings. After you check, depending on the configuration, you have to wait certain time until next check. Clicking the button also triggers and uplink.
2	Reset	When pressed for 10s the device resets, triggering another Join Request on SF9. Performs full refresh of the screen. Performing a Reset IS NOT equal to factory reset. All configured parameters are preserved.
3	Check (10s press)	When the check button is pressed for 10s continuously, child lock is enabled. To disable child lock, hold the Check button again for 10s. When in Child lock, the Check button is disabled and the user cannot refresh the CO2 reading manually.

Behavior

Start-up behavior

The device starts when you press the Reset button on the back one time.

At startup, the device measures the voltage of the supercapacitor, which is storing the energy harvested by the solar panel. If the voltage is within the working range of the device, the device will initiate a LoRaWAN Join-Request procedure on SF9.

Collecting and storing energy

The energy harvested by the Organic Solar Panel is stored in a supercapacitor. If the supercapacitor is discharged for some reason, the device will wake-up again when it has harvested enough power so that the voltage of the supercapacitor is within the working voltage of the device.

Example reasons for preliminary discharge can be: Device installed, but not provisioned in a LoRaWAN Network Server. Gateway not present.

The device has been stored in packaging for too long.

If you want to get started quickly, you can use the USB-C port to charge the capacitor from a 5VDC power supply, which takes approx 20 minutes.

The time it takes to recharge will depend on the lighting conditions, but in a brightly lit office with 1000 lux, it should take around 12 hours.

Using multiple energy sources

The CO2 Display has three options for power supply:

- Organic Solar Panel
- USB-C
- 2 or 4 AA Batteries (1.5VDC each)

You can use both solar and USB-C or AA batteries at the same time. If you use USB-C or AA batteries, the super capacitor will be charged and the solar harvesting will always be with highest priority.

Data transmissions

Once joined, the device will execute two types of transmissions:

Periodic, as configured

Immediate, when the Check button is pressed.

All transmissions are subject to complying with the duty-cycle limitations of LoRaWAN end-devices.

Calibration

The device comes pre-calibrated with ABC algorithm enabled. By default, the ABC algorithm is based on a 8-day period. It keeps a log of the minimum measured CO2 in ppm and at the end of the period considers the minimum value as if it was 400 for the next period. Meaning - if during the previous period the minimum measured CO2 was 430ppm, in the next period this value will be measured as 400ppm.

The ABC auto-calibration is a standard practice in the industry and is applicable for places with non-constant occupation. If a place is constantly occupied (e.g. manufacturing plant), you have to disable the ABC algorithm.

Apart from the ABC algorithm, if the device measures a value below 400ppm, it will run the ABC algorithm immediately, as CO2 values below 400ppm (background level) are considered impossible for smart building applications.

Commissioning



Before you install the device, we highly recommend that you first commission it on your LNS. Once the RESTART button is pressed, the device will initiate a LoRaWAN Join Procedure on SF9. Please, make sure you enable ADR in your LNS and/or mark the device as static. The lower the spreading factor, the better the performance of the energy storage will be.

- 1 Open your LoRaWAN® Network provider access panel and add the device using the supplied Serial Number, DevEUI, AppEUI (JoinEUI) and AppKey.

Device ID: 9X762945

DevEUI: 70B3D25D030000E1

AppEUI: 70B3D25D03000000

AppKey: A0658DFAE72131A5F0298A8C71

Register



The data is example. Do not use.

- 2 Continue the Installation with the instructions of your LoRaWAN® Network provider.

MClimate_LoRaWAN_51177			
Serial Number	DevEui	AppEui	AppKey
0000000000000000	70B3D25D030000E1	70B3D25D03000000	56C310A0200000000000000000000000



You can get DevEUI, AppEUI (JoinEUI) & AppKey information from the LoRaWAN® credentials .csv file we sent you with the fulfillment confirmation.

Placement guidelines



Do not place the device in direct sunlight, as this will result in gradual worsening of the performance of the solar panel. A few hours a day in direct sunlight wouldn't be an issue.

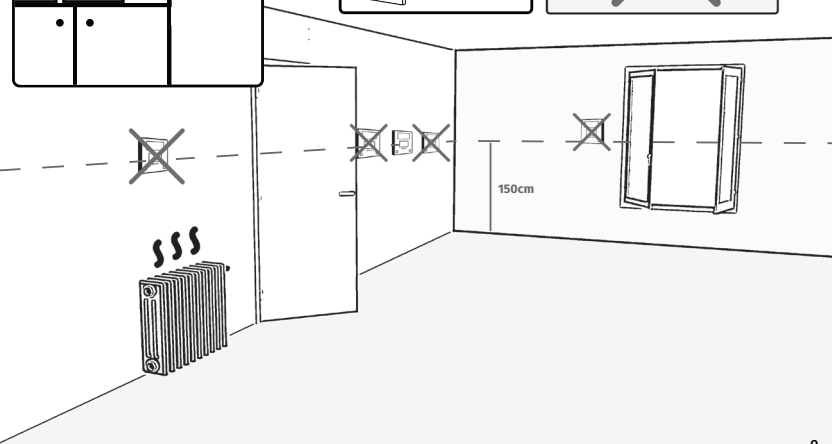
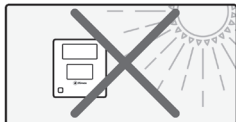
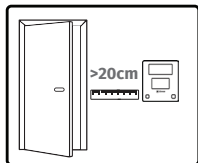
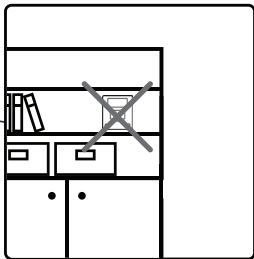

Installation

We recommend installing the device in an open environment (e.g. not in a recess) at 1.5m height. Do not install the device near big metal items as it will worsen the RF performance. Use double-sided tape to attach it to the surface or screws and dowels to attach the anti-theft bracket in a more permanent manner.

Once you've attached the anti-theft bracket, place the device on top so the two mounting points on the bracket correspond with the device's plastic. Slide down and secure with the security bolt on the bottom.

If you decide to insert AA 1.5VDC batteries into the device, you can use either 2 or 4 batteries.

We recommend using Energizer Ultimate Lithium AA L91. You can insert 4 batteries as shown on the device's plastic or 2 batteries as shown in the picture below.

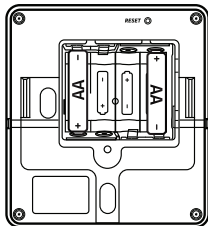
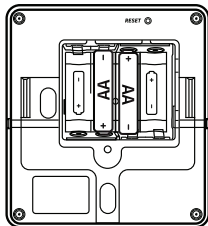
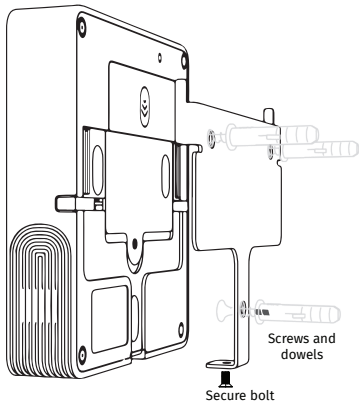

When using 2 or 4 AA batteries, please make sure that all batteries are new. If one of the batteries has lower voltage, it's not possible to use the full energy capacitance. That challenge is valid for all devices operated by multiple battery cells, e.g. your TV remote.



We
make any
building
smart.

www.mclimate.eu

Designed & Manufactured by MClimate in Europe.